

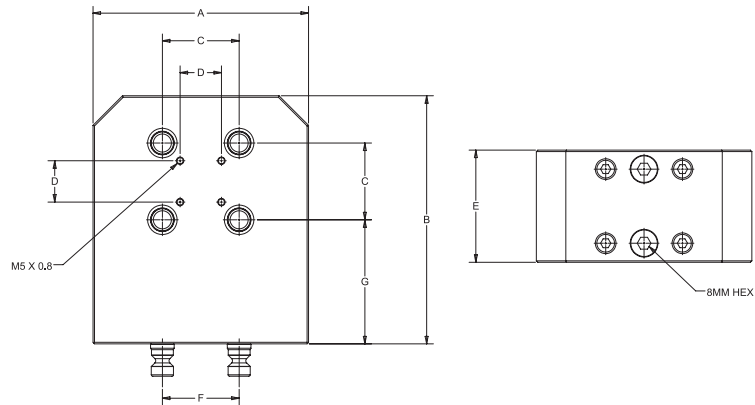

## Twin Base



Part Number	A (mm)	B (mm)	C (mm)	D (mm)	E (mm)	F (mm)	G (mm)	Weight lbs (kg)	Max. Torque ft*lbs (Nm)	Pull Stud
QL-400200	144	168	52	28	76	52	84	29.62 (13.44)	22 (30)	QL-200800
QL-400205	190	247	96	28	116	96	110	91.63 (41.56)	22 (30)	QL-200805

## Two Sided

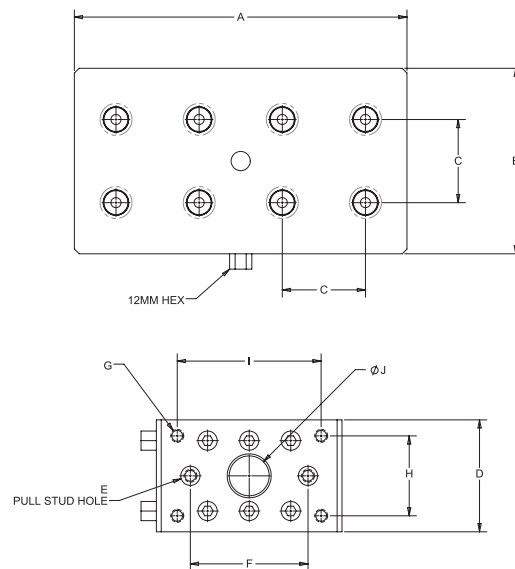

Part Number	A (mm)	B (mm)	C (mm)	D (mm)	E	F (mm)	G (mm)	H (mm)	I (mm)	J (mm)	Weight lbs (kg)	Max. Torque ft*lbs (Nm)	Pull Stud
QL-400210	208	116	52	70	QL-200800	73.538	M8 X 1.25	50	90	25H7	24.77 (11.24)	22 (30)	QL-200800
QL-400215	384	190	96	70	QL-200805	135.765	M10 X 1.5	50	140	25H7	80.76 (36.63)	22 (30)	QL-200805