

TAV50.T

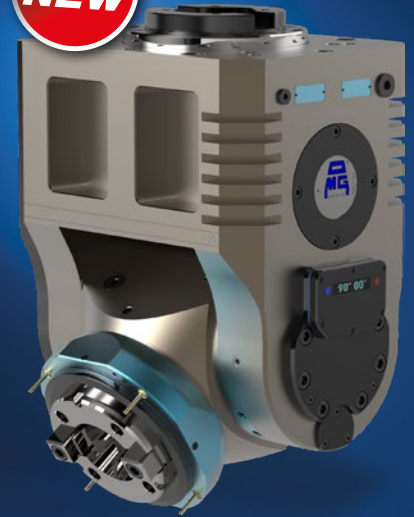

caratteristiche/features

ø 45
 M36
 6180 N
 1-2
 4000 rpm
 ±0,05 accuracy
OUTPUT

peso/weight



145 kg

rotazione/rotation



input



output

prestazioni/performance

Output data

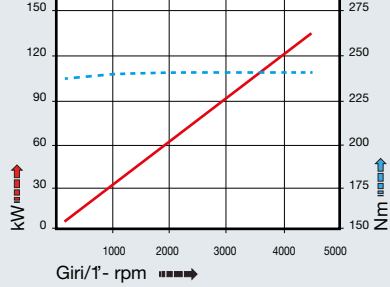

tipi mandrino disponibili / available spindle types

4 DIN69893-HSK
A100

5 COROMANT CAPTO®
C8

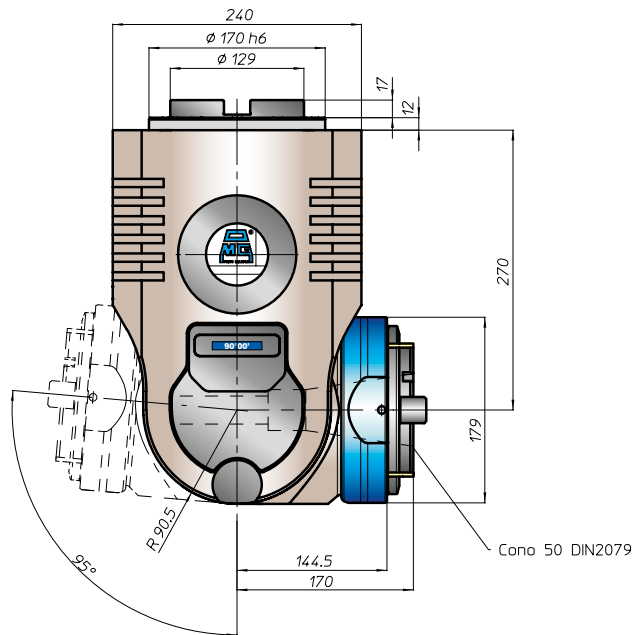
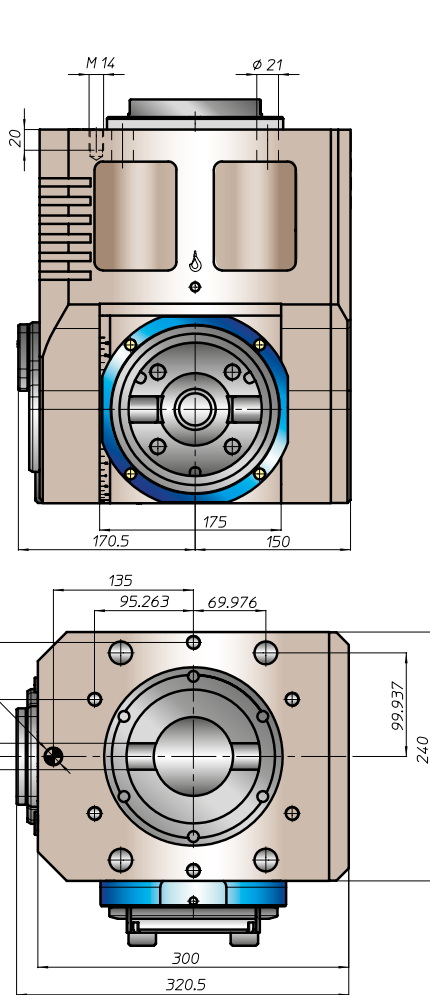

Equipaggiamento standard:

- pressurizzazione mandrino
- n. 4 ugelli orientabili vicino al mandrino
- regolazione angolare mandrino libera o posizionabile ogni 15°
- nel mandrino DIN2079 si possono utilizzare coni DIN69871-A50, MAS403-BT50

Standard equipment:

- spindle front pressurization
- nr 4 adjustable nozzle near the spindle
- free angle spindle adjustment or by pin each 15°
- on the spindle DIN2079 you can use shank DIN69871-A50, MAS403-BT50

esempio di collegamento - connection example

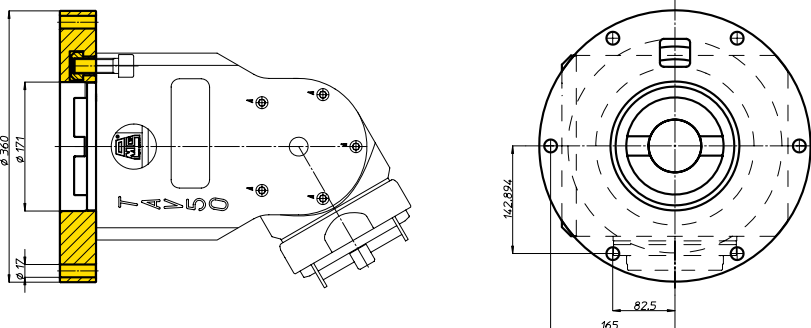

FH
BAH
TA.CP
TA
MO
HT
VH
TSI/TSX
T
MT-TC-TC3
Accessori
Accessories
Appendice tecnica
Technical supplement