

TAV20.P



caratteristiche/features

peso/weight

prestazioni/performances



22 kg

rotazione/rotation



input



output

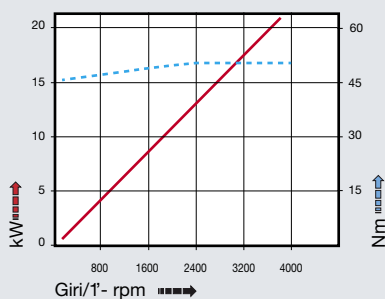

CONO SHANK	size	A	B	H	
				standard	optional
DIN69871	-	-	-	-	-
	50	173	35	110	-
ANSIB5.50	-	-	-	-	-
	50	-	-	110	-
BT	-	-	-	-	-
	50	181	45	110	-
HSK	-	-	-	-	-
	80	182	46	110	-
CAPTO	-	-	-	-	-
	C8	177	-	110	-
KM	-	-	-	-	-
	100	173	-	110	-
DIN2080	-	-	-	-	-
	50	149	16	110	-
ANSIB5.18	-	-	-	-	-
	50	149	16	110	-

tipi mandrino disponibili / available spindle types

- 1 DIN6388-ER
ER40
- 2 Albero portafresa
Milling shaft
Ø32
- 3 Weldon
Whistle-Notch
Ø20-Ø25
- 4 DIN69893-HSK
HSK50
- 6 ABS
Licenza KOMET®
ABS50

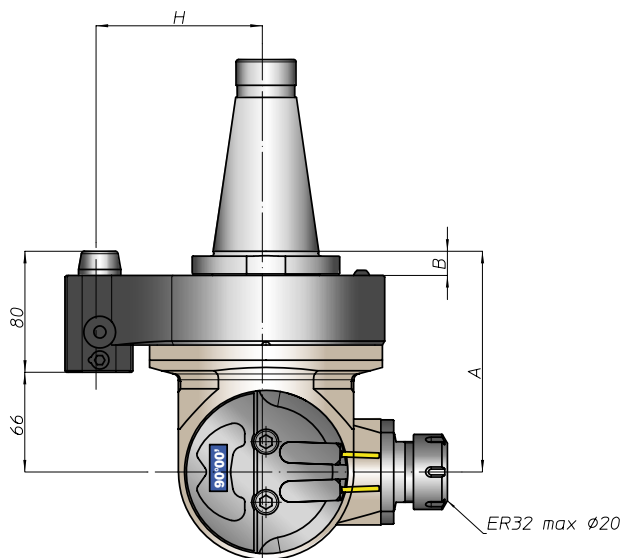
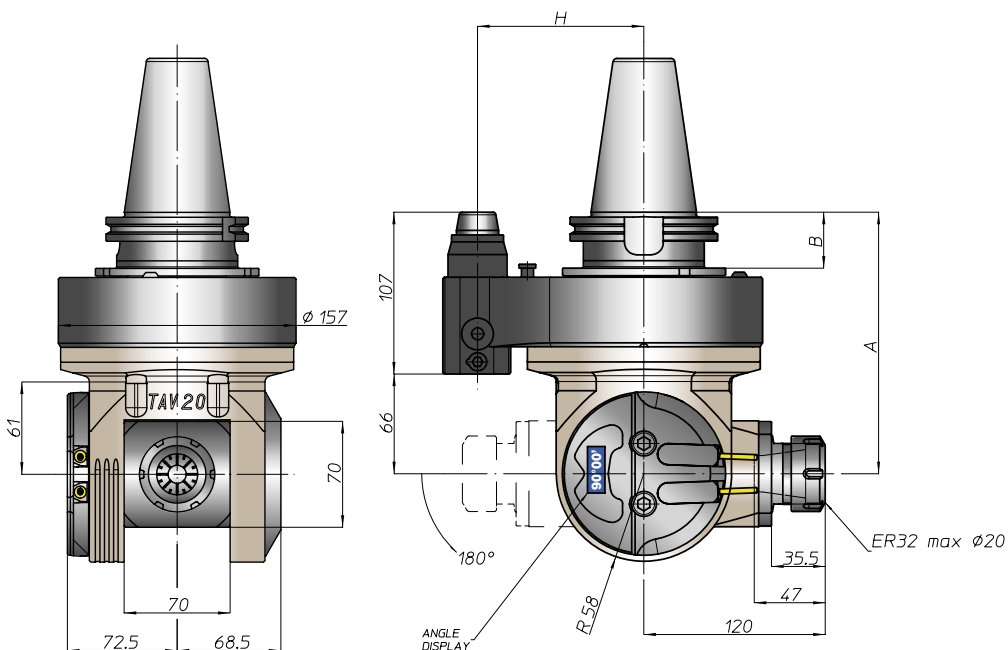

★ Option: Dual Contact



FH
BAH
TA.CP
TA
MO
HT
VH
TSI/TSX
T
MT-TC-TC3
Accessori
Accessories
Appendice tecnica
Technical supplement