



teste ad angolo  
angle heads

**LIGHT  
DUTY**

### NUOVA GENERAZIONE DI TESTE AD ANGOLO LIGHT DUTY SERIE CP

Questa nuova generazione di Teste ad Angolo inaugura una linea innovativa nata per tutte le macchine utensili, anche di piccole dimensioni e dagli ingombri contenuti, dove si richiedono performances elevate nonostante la capacità di peso limitata sul cambio utensile. Quindi Teste ad Angolo più leggere ma con qualità e affidabilità tipiche dei nostri prodotti.

L'obiettivo di contenere il peso è stato raggiunto costruendo il corpo in lega di alluminio aeronautico e adottando un sistema antirotante semplificato e alleggerito, pur rimanendo inalterata la modularità dei coni di attacco tipica della serie Heavy Duty.

La caratteristica principale di questa nuova generazione di Teste ad Angolo è di potere eseguire forature, maschiature e lamature su quelle macchine utensili dove il peso del cambio utensile ha forti limitazioni o quando i costi di produzione devono essere estremamente competitivi.

Caratteristiche comuni della nuove Teste ad Angolo serie CP sono:

- perno antirotante conico come tutta la produzione O.M.G. che, al contrario dei perni cilindrici, elimina i giochi angolari
- possibilità di utilizzo su macchine dove già presente Stop-Block della serie Heavy Duty per una perfetta compatibilità di tutta la gamma
- sistema di orientamento testa ad angolo in macchina ottimizzato, per una più facile e rapida registrazione
- ingranaggi Gleason con evolvente rettificato
- lubrificazione a vita
- peso estremamente ridotto per Teste ad Angolo con queste capacità di lavoro
- utilizzo su centri di lavoro di piccole dimensioni
- versioni anche prolungate per una maggiore flessibilità di gamma
- coni disponibili: DIN69871, BT, BBT, HSK, CAT .

### NEW GENERATION OF LIGHT DUTY ANGLE HEADS

*The new generation of TA.CP angle heads introduces an innovative line targeting all the small machine-tools with restrained size, but with high performances despite limited weight on tool changer. Therefore TA.CP angle heads are lighter but with both quality and reliability typical of our products.*

*The goal of containing the weight has been reached by making the head body in aeronautical aluminium alloy and by engineering a simplified and lightened torque-arm system, yet maintaining unchanged the back-end shank modularity characteristic of our Heavy Duty range.*

*The major feature of this new generation of angle heads is to be able to perform drilling, tapping and reaming operations on machine-tools with high limitations on tool changer weight, or when production costs must be extremely competitive.*

*The major specifications of the new TA.CP range are:*

- conical (V-shape) torque-arm pin like all OMG heads which eliminates any angular backlashes, unlike cylindrical type of pins
- possibility of using them on machines which are already equipped with a Stop-Block of the Heavy Duty range, getting them fully compatible with our complete range
- optimized indexing set-up for an easier and faster adjustment on machine-tools
- lubricated-for-life
- ground involute Gleason type gears
- extremely reduced weight in comparison to the capabilities and performances of this new range of angle heads
- usable on small size machining centres
- extended length versions available further completing this new range
- DIN69871, BT, BBT, HSK and CAT back-end shanks available





testa ad angolo - angle head

## TA07.CP

## caratteristiche/features



ø 7



M6



1-1



8000

## peso/weight



2,1 kg



2,5 kg

## rotazione/rotation



input



output

## prestazioni/performance

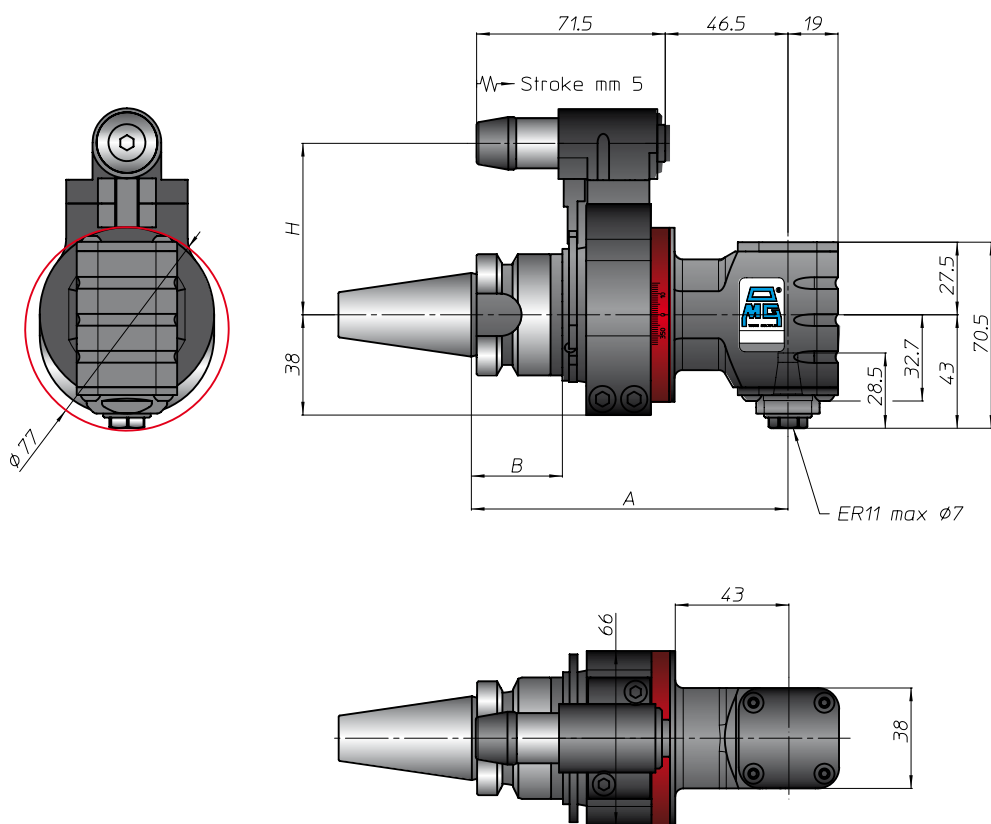
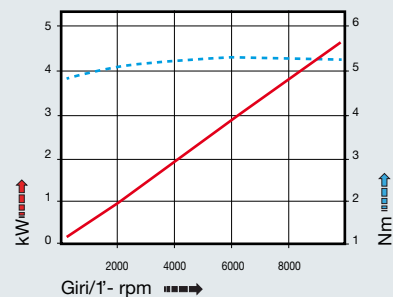

CONO SHANK	size	H				
		A	B	standard	optional	
DIN69871	30	120	35	65	-	
	40					
ANSIB5.50	40			65	-	-
	-					
BT	30			65	-	-
	40					
HSK	63			44	65	-
	-					
DIN69893	-			129	-	-
	-					
CAPTO	-	-	-	-		
	-					
KM	-	-	-	-		
	-					
DIN2080	-	-	-	-		
	-					
NMTB	-	-	-	-		
	-					
ANSIB5.18	-	-	-	-		
	-					



# TA10.CP

caratteristiche/features



peso/weight

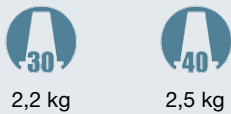

rotazione/rotation



prestazioni/performance

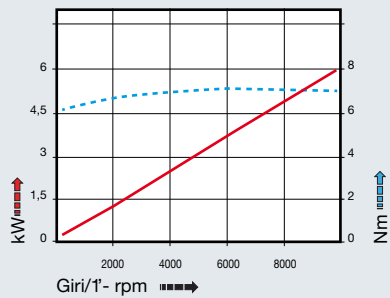

CONO SHANK	size	A	B	H					
				standard	optional				
DIN69871	30	120	35	65	-				
	40			-					
	-			-					
ANSIB5.50	CAT 40			-	-	65	-		
	-			-	-	-	-		
BT	30			-	-	65	-		
	40			-	-	-	-		
DIN69893	63			129	44	65	-		
	-					-			
	-					-			
CAPTO	-					-	-	-	-
	-					-	-	-	-
KM	-	-	-			-	-		
	-	-	-	-	-				
	-	-	-	-	-				
DIN2080	-	-	-	-	-				
	-	-	-	-	-				
	-	-	-	-	-				
ANSIB5.18	NMTB	-	-	-	-				
	-	-	-	-	-				

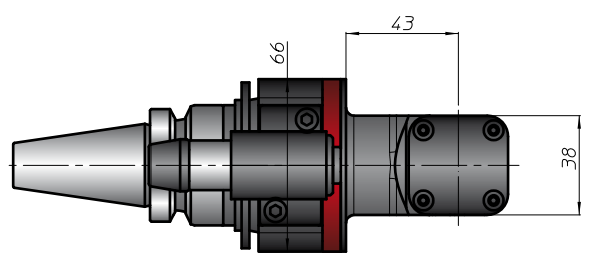
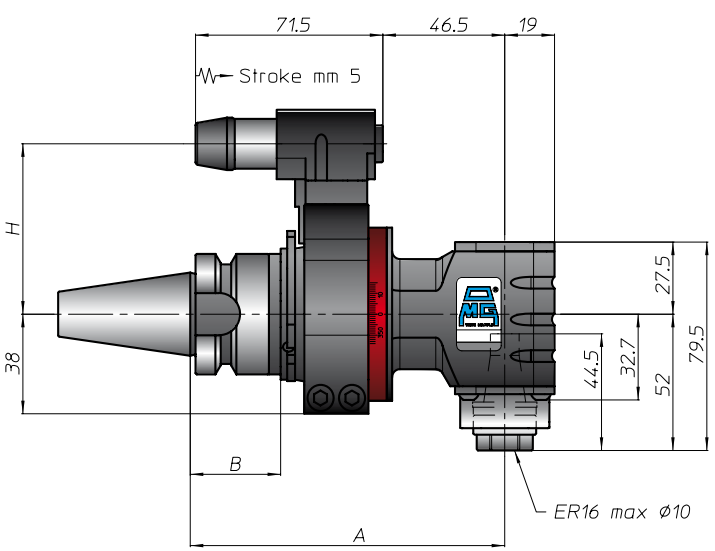
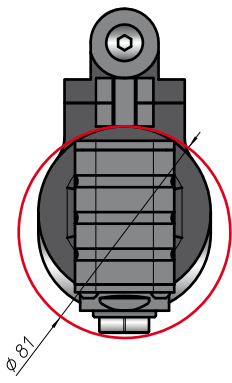

BAH  
TA.CP  
TA  
MO  
HT  
VH  
TSI/TSX  
T  
MT-TC-TC3  
Accessori  
Accessories  
Appendice tecnica  
Technical supplement





testa ad angolo - angle head

# TA13.CP

## caratteristiche/features



ø 13



M10



1-1



6000

## peso/weight



5 kg



7,5 kg

## rotazione/rotation



input



output

## prestazioni/performance

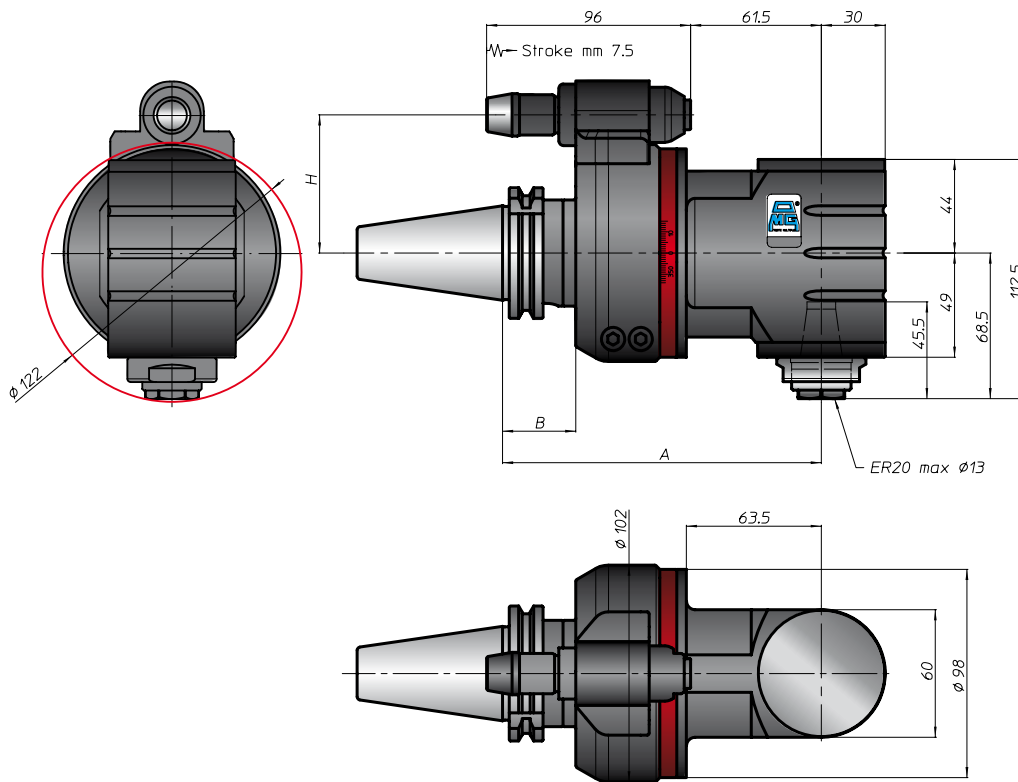
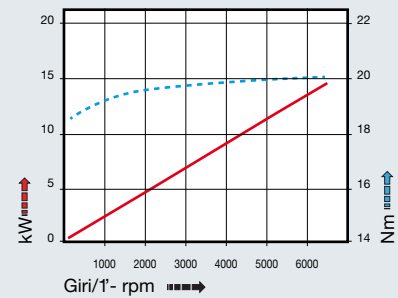

CONO SHANK	size	H			
		A	B	standard / optional	
DIN69871	30	150	35	65	-
	40			80	-
	45			80	-
ANSIB5.50	CAT	158	45	65	-
	40			80	-
BT	40	158	45	65	-
	50			80	-
HSK	63	159	46	44	65
	80			80	-
	100			80	-
ISO28623	-	-	-	-	-
KM	-	-	-	-	-
DIN2080	-	-	-	-	-
NMTB	-	-	-	-	-
ANSIB5.18	-	-	-	-	-



# TA13.CPL

caratteristiche/features



peso/weight



rotazione/rotation



prestazioni/performance

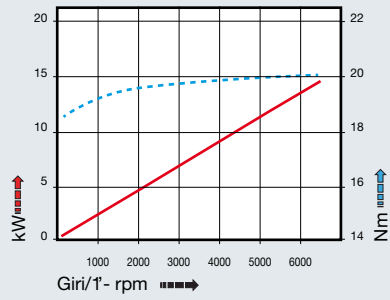

CONO SHANK	size	A	B	H	
				standard	optional
DIN69871	30	230	35	65	-
	40			80	-
	45			80	-
	50			80	-
ANSIB5.50	40	230	35	65	-
	50			80	-
BT	40	238	45	65	-
	50			80	-
HSK	63	239	46	65	-
	80			80	-
	100			80	-
ISO28623	CAPTO	-	-	-	-
KM	-	-	-	-	-
	-	-	-	-	-
	-	-	-	-	-
DIN2080	-	-	-	-	-
ANSIB5.18	NMTB	-	-	-	-
	-	-	-	-	-

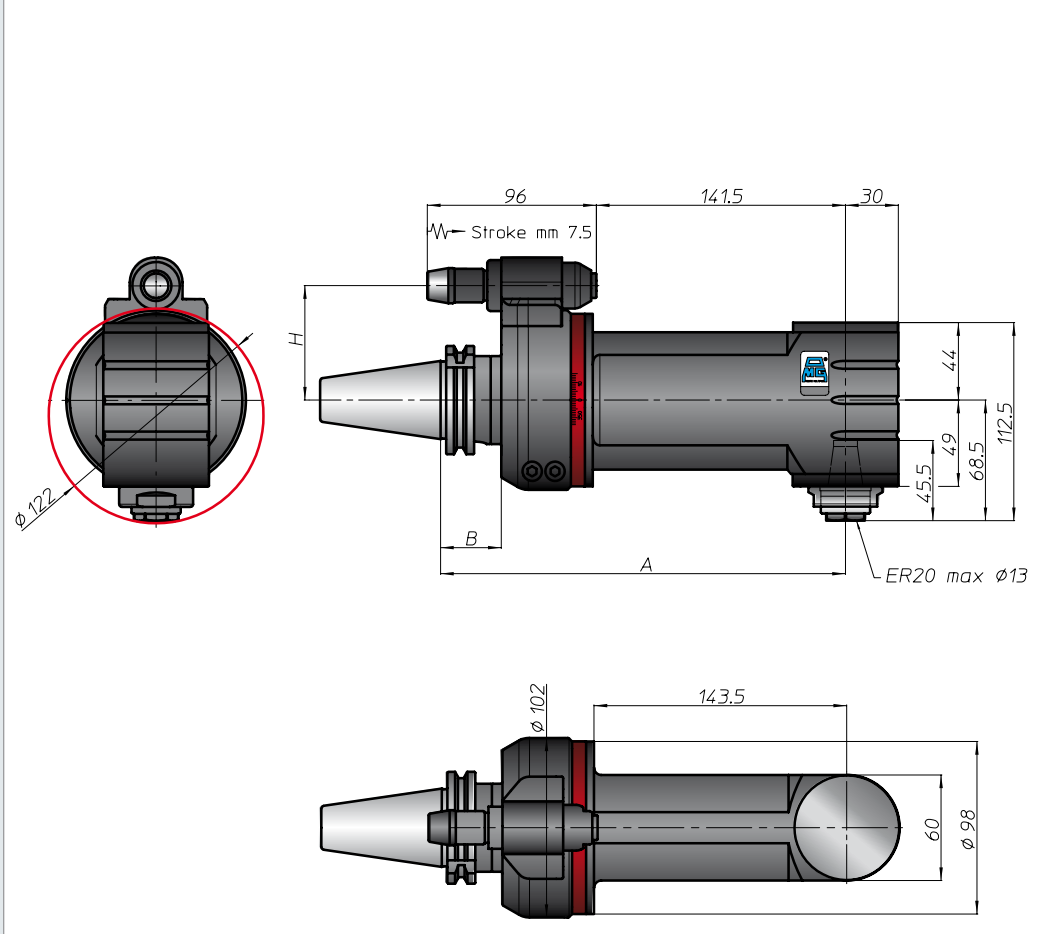

BAH  
TA-CP  
TA  
MO  
HT  
VH  
TSI/TSX  
T  
MT-TC-TC3  
Accessori  
Accessories  
Appendice tecnica  
Technical supplement





testa ad angolo - angle head

# TA16.CP

## caratteristiche/features



ø 16



M12



1-1



4000

## peso/weight



5 kg



7,5 kg

## rotazione/rotation



input



output

## prestazioni/performance

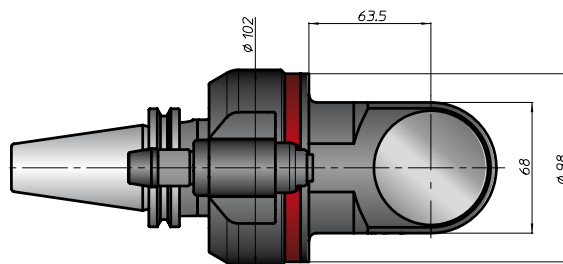
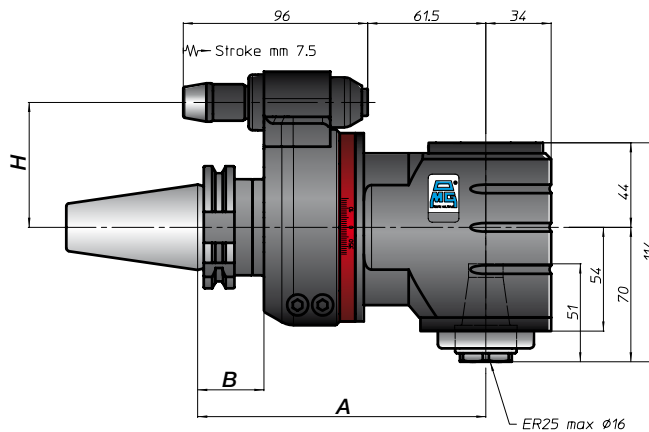
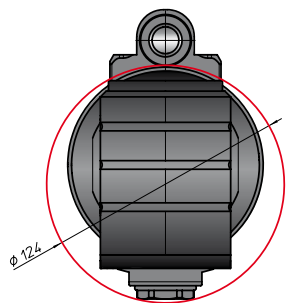
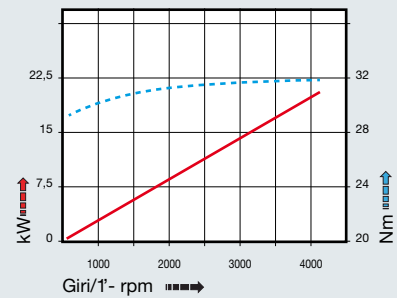

CONO SHANK	size	H			
		A	B	standard	optional
DIN9871	-			65	
	40				
	45			80	
ANSI B5.50	50	150	35		
	CAT			65	
	50			80	
BT	40			65	
	50	158	45	80	
DIN9893	63		44	65	
	80	159			
	100		46	80	
ISO 28623	CAPTO				
	-				
	-				
KM	-				
	-				
	-				
DIN2080	-				
	-				
	-				
ANSI B5.18	NMTB				
	-				

# TA16.CPL



caratteristiche/features



peso/weight

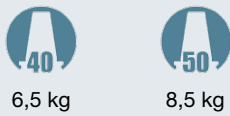

rotazione/rotation



prestazioni/performance

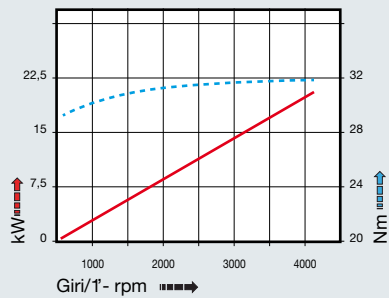

CONO SHANK	size	A	B	H	
				standard	optional
DIN69871	-	230	35	65	-
	40			80	
	45			80	
ANSIB5.50	40	238	45	65	-
	50			80	
BT	40	239	46	65	-
	50			80	
HSK	63	239	46	65	-
	80			80	
	100			80	
ISO26623	-	-	-	-	-
KM	-	-	-	-	-
DIN2080	-	-	-	-	-
ANSIB5.18	-	-	-	-	-

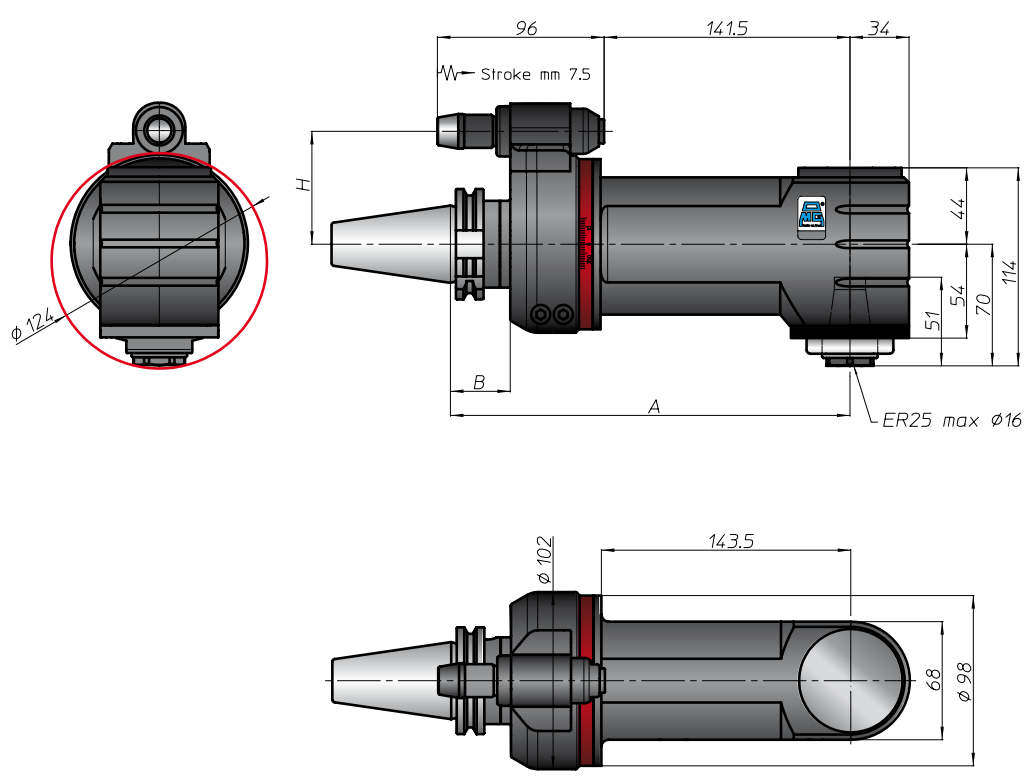

BAH  
TA-CP  
TA  
MO  
HT  
VH  
TSI/TSX  
T  
MT-TC-TC3  
Accessori  
Accessories  
Appendice tecnica  
Technical supplement







# Gallery



BAH

TA-CP

TA

MO

HT

VH

TSI/TSX

T

MT-TG-TC3

Accessori  
Accessories

Appendice tecnica  
Technical supplement





Il gruppo antirotante ricopre una funzione di fondamentale importanza nella qualità di lavorazione della testa ad angolo. Per questo motivo i tecnici della OMG hanno studiato e messo a punto un antirotante di nuova concezione i cui punti salienti sono:

- il perno conico
- registrazione flangia di fasatura semplice, veloce e precisa.

Il perno conico permette una maggiore rigidità del sistema antirotante rispetto ai tradizionali, dotati di perni di  $\varnothing 18$  mm, perché si eliminano i giochi. Conseguenza un miglioramento della rigidità sia angolare che assiale.

Il perno conico è forato e perciò predisposto per il passaggio del liquido refrigerante ad un max di 10 bar. Qualora il cliente volesse portare il liquido vicino all'utensile, occorre semplicemente installare un piccolo tubo.



Quando possibile, nella Vostra applicazione, posizionate il perno conico dalla parte opposta al mandrino della testa ad angolo.

# Antirotante Torque arm

Teste ad angolo TA07.CP, TAV07.CP  
Angle heads TA07.CP, TAV07.CP

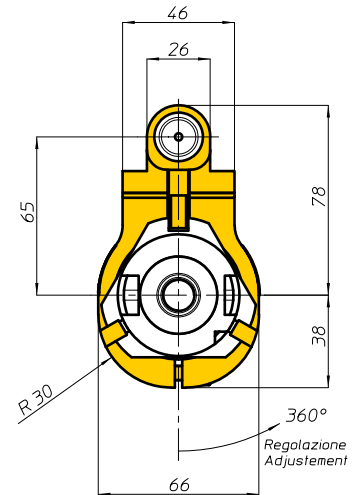
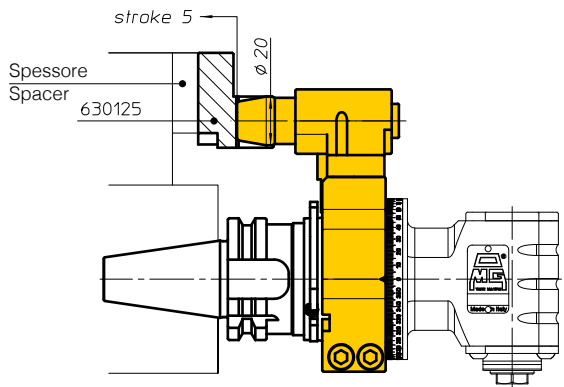

Teste ad angolo TA13.CP, TA16.CP con interasse H=65  
Angle heads TA13.CP, TA16.CP with centre distance H=65

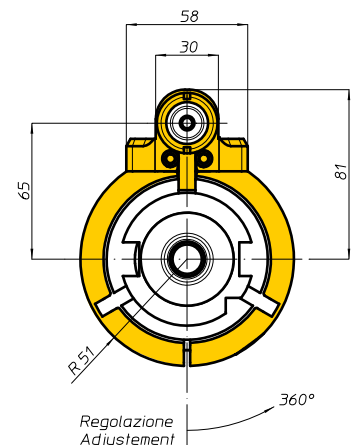
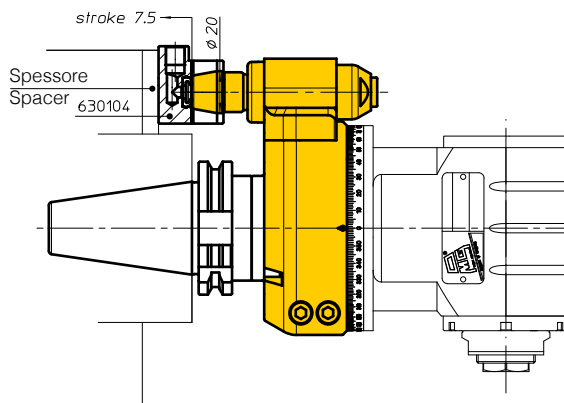

Teste ad angolo TA13.CP, TA16.CP con interasse H=80  
Angle heads TA13.CP, TA16.CP with centre distance H=80

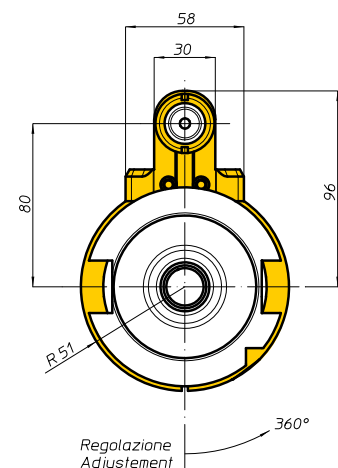
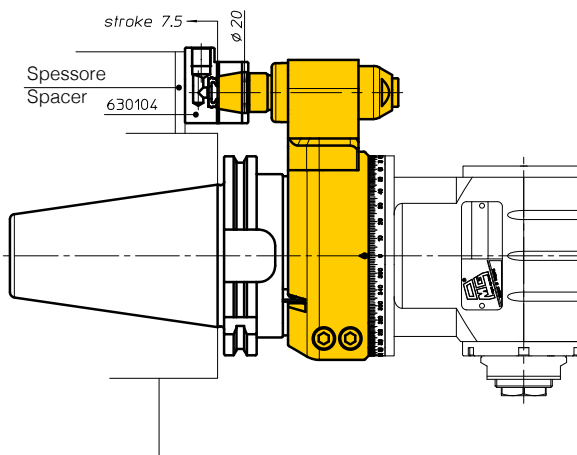

# Stop-block

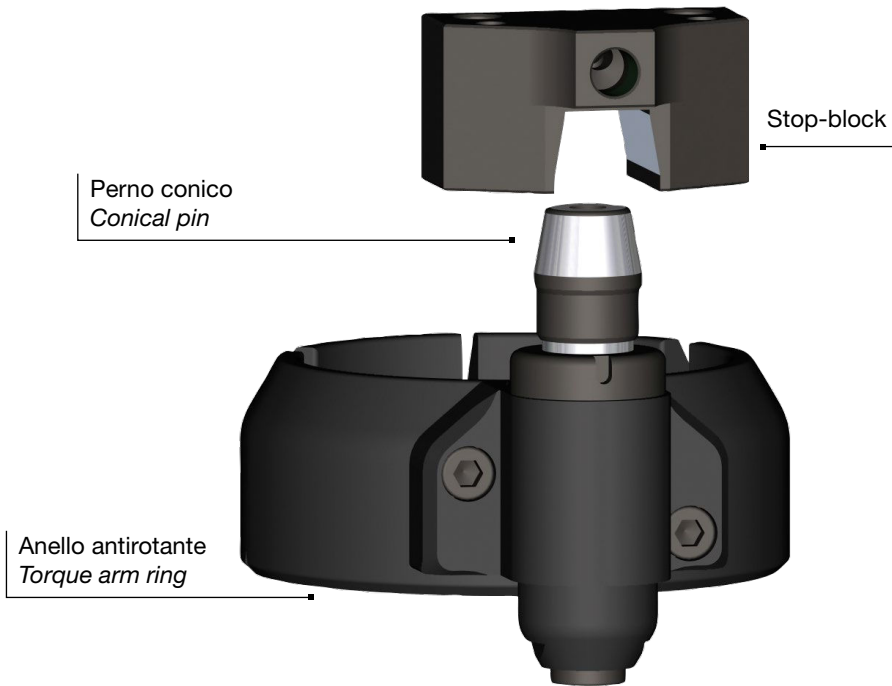

Stop-block (cod. 630125)

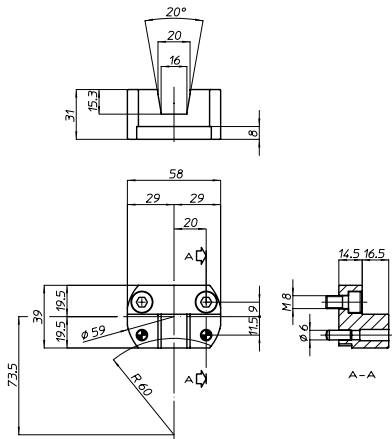

Stop-block (cod. 630104)

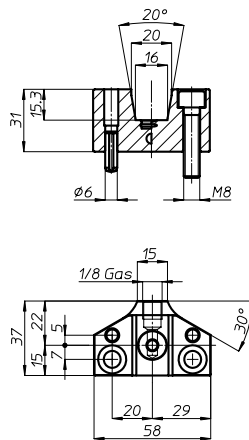

Stop-block preparati per  
Stop-block made for

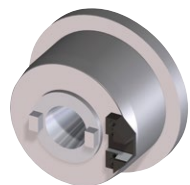

HAAS

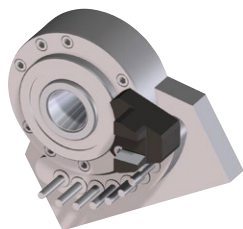

DMG Milltap

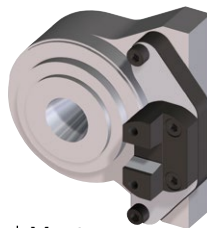

Mectron

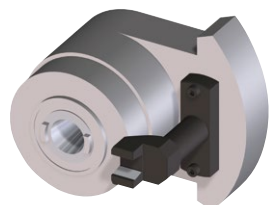

Brother



Fanuc Robodrill



The torque-arm system is fundamental to achieve high quality machining results.

This is why the OMG technicians have engineered and fine tuned a new generation torque-arm system with following characteristics:

- conical (V-shape) timing pin
- simple, fast and precise timing pin adjustment

The conical (V-shaped) pin ensures a higher rigidity to the torque-arm system (than the traditional ones equipped with  $\varnothing 18$  mm pins) because cancelling backlashes. The result is the enhancement of both angular and axial rigidity.

The conical timing pin is equipped with a hole and therefore prepared to let coolant through it up to max 10 bar. When customer needs coolant close to the tool, he can install just a small pipe.



Position the conical pin on the opposite side of the angle head spindle when possible in your application.

