



teste ad angolo
angle heads



Un prodotto fondamentale che grazie alla riduzione dei piazzamenti in lavorazione, vanta un contributo prezioso per l'aumento della produttività necessaria per competere su tutti i mercati: parliamo della Testa ad Angolo, da considerare come parte integrante del parco utensili della macchina.

- **Esperienza** - E' dall'inizio degli anni '60 che O.M.G. crea prodotti. L'esperienza non si acquista, si acquisisce. La realizzazione fin dai primi anni di prodotti speciali ha formato le competenze per lo sviluppo di una gamma di Teste ad Angolo articolata e performante, idonea alla clientela più esigente che crede negli investimenti per conquistare nuovi mercati.
- **Tradizione** - Il termine "qualità" viene spesso citato, ma non significa soltanto utilizzare macchine utensili tecnologicamente avanzate per ottenere lavorazioni precise. La qualità è il risultato di esperienze pratiche, di calcoli matematici, di sfide vinte e perse ma comunque accettate, di cui fare grande tesoro.
- **Innovazione** - Le Teste ad Angolo Speciali di ultima generazione offrono prestazioni superiori a tutti gli standard e condizionano spesso la produzione fino al punto da divenire indispensabili nel completamento del processo produttivo. Da queste OMG continua a trarne grande beneficio e soddisfazione con soluzioni tecniche poi riproposte sulle Teste ad Angolo Standard a catalogo.
- **Modularità** - Indispensabile oggi la flessibilità produttiva, ancora maggiore negli investimenti. In questa ottica gli elementi modulari delle Teste ad Angolo consentono di ridurre i costi ed aumentare i benefici.
- **Personalizzazione** - Se l'ampia gamma di Teste ad Angolo standard non risponde all'esigenza specifica, siamo pronti a progettare e costruire il prodotto speciale, forti dell'esperienza di centinaia di soluzioni operative volte alle più svariate attività produttive.

An ultimate product that gives a valuable contribution to the productivity increase by reducing the management of the pieces to be machined, necessary condition to compete in the markets all over the world: we are talking about the Angle Heads, to be considered an integrant part of the machine tools range.

- **Experience** - O.M.G. engineers its products since the beginning of the '60's. The experience cannot be bought but it is acquired. Since that time the achievement of special products gave us the expertise to develop a range of Angle Heads very broad and performing, suitable to the most demanding customers believing in investments to gain new market shares.
- **Tradition** - The word "quality" is often mentioned, but it does not mean just to use technologically advanced machine tools to get accurate machining. The quality is the result of practical experiences, of mathematical calculations, of won and lost challenges, anyway accepted, which are treasured.
- **Innovation** - The last generation Special Angle Heads offers performances much higher than all standards, and they often affect the production cycles until becoming indispensable when completing production stages. O.M.G. keeps getting beneficial results from his special range which is also reflected into the standard Angle Heads range.
- **Modularity** - Nowadays the productivity flexibility is mandatory, and even more in the investments. Towards this goal the O.M.G. Angle Heads modular system allows cost reductions and to increase profits.
- **Customization** - And if the wide range of standard Angle Heads will not meet your requirements, we are ready to engineer and to manufacture a new Special Angle Head product, always supported by our experience of hundreds of solutions done for many different industrial activities.



Panoramica prodotti

Product overview



TAR

Piccole per piccoli spazi.

Tiny for narrow spaces.

Pagina/Page: 3-10



TA

Lavorazione singola di foratura e fresatura.

Drilling and milling machining.

Pagina/Page: 3-18



TA... D

Input refrigerante attraverso lo stop-block e uscita attraverso il centro utensile.

Input coolant from stop-block, and output through tool spindle.

Pagina/Page: 3-38



TAO

Mandrino offset, lavorazione in spazi ristretti ed ottima performance in fresatura.

Offset spindle, machining in narrow spaces, and excellent results in milling operations.

Pagina/Page: 3-48



TAF

Mandrino fisso, angolo su richiesta del cliente.

Fixed spindle with custom angle.

Pagina/Page: 3-67

Simboli/Icons



Capacità di foratura
Drilling capacity



Pressione
Pressure



Maschiatura
Tapping



Peso
Weight



Rapporto entrata/uscita
Ratio input/output



N° max giri in uscita
Max output RPM

Panoramica prodotti

Product overview

BAH

TA.CP

TA

MO

HT

VH

TSI/TSX

T

MT-TC-TC3

Accessori
AccessoriesAppendice tecnica
Technical supplement

3-3



TA... L

Versione allungata per lavorazioni singole di foratura e fresatura.

Length stretched version for drilling and milling single machining operations.

Pagina/Page: 3-11



TA... 2P

Due mandrini contrapposti di 180°.

180° two opposed spindles.

Pagina/Page: 3-32



TAO... PD

Mandrino offset, input refrigerante attraverso il centro cono, uscita attraverso centro utensili con pressione 70 bar.

Offset spindle, input coolant through machine taper, output through tool spindle at 70 bar pressure.

Pagina/Page: 3-49



TAV

Mandrino variabile $\pm 90^\circ$.

$\pm 90^\circ$ adjustable spindle.

Pagina/Page: 3-56

Simboli/Icons



Peso con cono 40
Weight with size 40 shank



Dual
Contact



Peso con cono 50
Weight with size 50 shank



Rotazione in ingresso
Input rotation



Rotazione in uscita
Output rotation

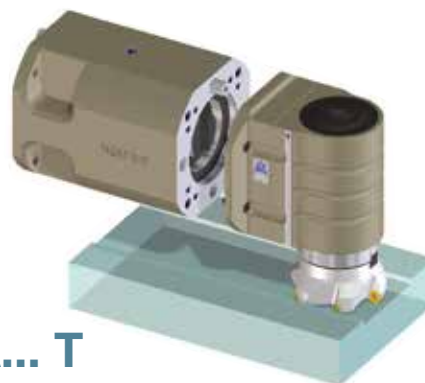

TA... T

Connessione alla macchina tramite flangia.

To be connected to the machine by flange.

Pagina/Page: 3-72



Sistema modulare per applicazioni flessibili

Modular system for flexible application



- 1 Testa ad angolo con presa utensile ER standard, oppure vedi tipi Mandrino.
Angle Head with standard ER tool connection, or check other spindle types.
- 2 Antirotante standard “senza gioco”, oppure su specifico design per la vostra macchina utensile.
No backlash standard torque arm, or under specific design for your machine tool.
- 3 Coni macchina standard o speciali su richiesta.
Standard or on-demand machine tapers.

Modularità Coni – Sono disponibili tutti i tipi di cono macchina, da sostituire tramite un esclusivo accoppiamento di precisione che crea un sistema rigido pari ai cono integrali, ma con i pregi dell’intercambiabilità.

Modularità Antirotanti – esistono fondamentalmente tre dimensioni unificate di interasse tra il centro cono ed il centro perno antirotante: 65 mm per i cono grandezza 40, 80 mm per i cono grandezza 50 ed in alcuni casi anche 110 mm. Sono disponibili tutte le dimensioni e sostituire il gruppo antirotante è una operazione banale.

Taper modularity - All the different machine tapers are available, and can be replaced with an exclusive precision coupling system generating a rigid system equal to integral tapers, but with additional interchangeability quality.

Torque arm modularity - Essentially three unified dimensions between taper and torque-arm centers exist: 65 mm for the taper size 40, 80 mm for the taper size 50 and also 110 mm in some cases. All sizes are available and torque-arm replacement is very simple.

Prese utensili - tipi mandrino

Clamping systems and spindle types



1 DIN6388-ER



2 Albero portafrese
Milling shaft



3 Weldon
Whistle-Notch



4 DIN69893-HSK



5 COROMANT
CAPTO®



6 ABS
Licenza KOMET®



7 ISO-DIN2079
NMTB-BT

Refrigerante utensile

Coolant tool



STANDARD

TA... PD
max 10 bar

TAO... PD
max 70 bar

TAF... PD
max 70 bar

TAV... PD
max 70 bar

Il circuito refrigerante è standard - Tutte le teste sono provviste di canalizzazione interna, che parte dal perno dell'antiro-tante e termina sull'ugello vicino all'utensile, senza alcun costo aggiuntivo.

Refrigerante da cono macchina - La costruzione offset delle Teste ad Angolo serie TAO consente il montaggio di tenute ad alta pressione affidabili nel tempo ed isolate dalle parti vitali della Testa ad Angolo, per un sicuro utilizzo di utensili con passaggio refrigerante interno.

Coolant system is standard - All our Angle Heads are supplied with an internal channel system, which starts from the torque-arm pin and ends on the nozzles next to the tool, without additional cost.

Coolant system from machine taper - The offset construction of the TAO Angle Head series allows to fit high pressure seals which are time reliable and isolated from the vital parts of the Angle Heads, for a safe usage of tools with internal coolant transit.



Antirotante Torque arm



STANDARD



TriBlock®



QuadBlock®



Studiato e realizzato su
specifica richiesta.
*Customized design according
to your application.*

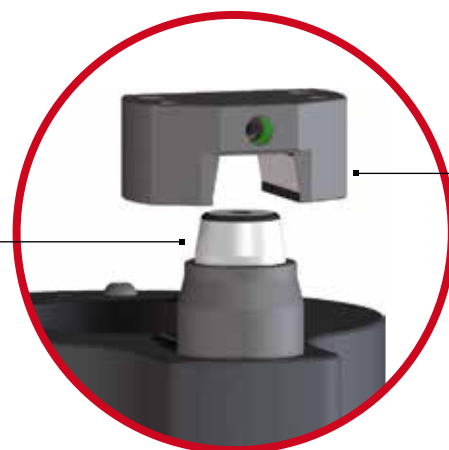

Stop-block

Perno conico
Conical pin

Prestazioni superiori - L'antirotante standard permette di cambiare la testa in automatico. Il sistema di accoppiamento fra perno conico regolabile assialmente e lo stop-block con sede a "V", permette di annullare la tolleranza tra le parti creando un sistema rigido, senza giochi. Evidenti sono i vantaggi: maggiore durata degli utensili, maggiore durata dei cuscinetti, risparmi in termini di manutenzione con conseguente riduzione dei costi.

Massima stabilità - I sistemi antirotanti **TriBlock** e **QuadBlock** di O.M.G. con perni regolabili permettono di contrastare al meglio le spinte radiali e assiali con la possibilità di affrontare in sicurezza lavorazioni di fresatura o finitura fino a ora mai effettuate con le teste ad angolo, destinate inizialmente a diversi piazzamenti pezzo.

Higher performances - The standard torque arm allows an automatic change of the head. The coupling system between the conical pin, which can be axial adjusted, and the "V"-housing of the stop-block, allows to cancel any tolerance between those parts generating a rigid and backlash free system. The advantages are evident: longer life of tools, longer life of bearings, maintenance savings with consequent cost reductions.

Maximum stability - The O.M.G. **TriBlock** and **QuadBlock** torque arm systems with adjustable pin allow to oppose both radial and axial thrusts at their best, with the possibility of milling or finishing with total security, which was not possible until nowadays because requiring several changes of placement of the piece to be machined.



Connessione alla macchina tramite flangia

Machine connection by flange



1	Macchina	<i>Machine</i>
2	Flangia di connessione	<i>Connection flange</i>
3	Giunto ISO 40/50	<i>Driving joint ISO 40/50</i>
4	Estensione	<i>Extension</i>
5	Testa ad angolo TA... T	<i>Angle head TA... T</i>



Qualità dei componenti

Quality of components



CORPO/BODY

Corpo testa in acciaio: massima rigidità e minima dilatazione termica.

Heady body in steel: maximum rigidity and minimum thermal expansion.



CUSCINETTI/BEARINGS

Cuscinetti obliqui in classe di precisione ABEC7/9.

Angular contact ball bearings of precision class ABEC7/9



INGRANAGGI/GEARS

Ingranaggi Gleason con evolvente rettificato: massime performances e minori vibrazioni.

Gleason rectified gears: maximum performances and minimum vibration.



DESIGN

Design compatto, che insieme alle specifiche sopra descritte, consente: alte performances, elevate velocità, lunga durata degli utensili.

Compact design that, along with above mentioned described specifications, allows: high performances, high speeds, long life of tools.

Materiali - Tutte le teste ad angolo standard sono in acciaio ricavate dal pieno per fresatura a pareti sottili, minimo ingombro e minor peso. Hanno il corpo trattato con nipro, trattamento anticorrosione, che garantisce alta protezione contro la ruggine, lubrificanti aggressivi e acidi.

Componenti - Tutte le teste montano cuscinetti di precisione, oppure conici nelle versioni per grandi asportazioni. Si utilizzano solo cinematismi trattati termicamente e coppie coniche Gleason con dentatura rettificata. Lubrificazione con grasso long-life.

Materials - All our standard Angle Heads are made from solid steel for thin wall milling, resulting with the minimum possible size and less weight. Body is nipro treated and anti-corrosion coated giving the guarantee of high protection against rust as well as acid and aggressive lubricant-coolants.

Components - All our Angle Heads integrate precision bearings, or tapered roller bearings when models are for big removal machining. We only use thermal treated cinematic components and Gleason bevel gears with rectified teeth. Lubrication is with long-life grease.

Packaging



Le Teste ad Angolo sono racchiuse in robusta valigetta di materiale termoplastico e corredate di una completa dotazione di accessori:

- Stop-block standard con passaggio refrigerante
- Confezione di chiavi per messa in funzione e manutenzione
- Grasso di mantenimento
- Manuale istruzioni dettagliato per messa in funzione e manutenzione

The Angle Heads are packed in a strong thermoplastic case together with a complete set of accessories:

- *Standard stop-block with coolant way*
- *Set of keys for operation and maintenance*
- *Grease tube*
- *Operation and maintenance manual*



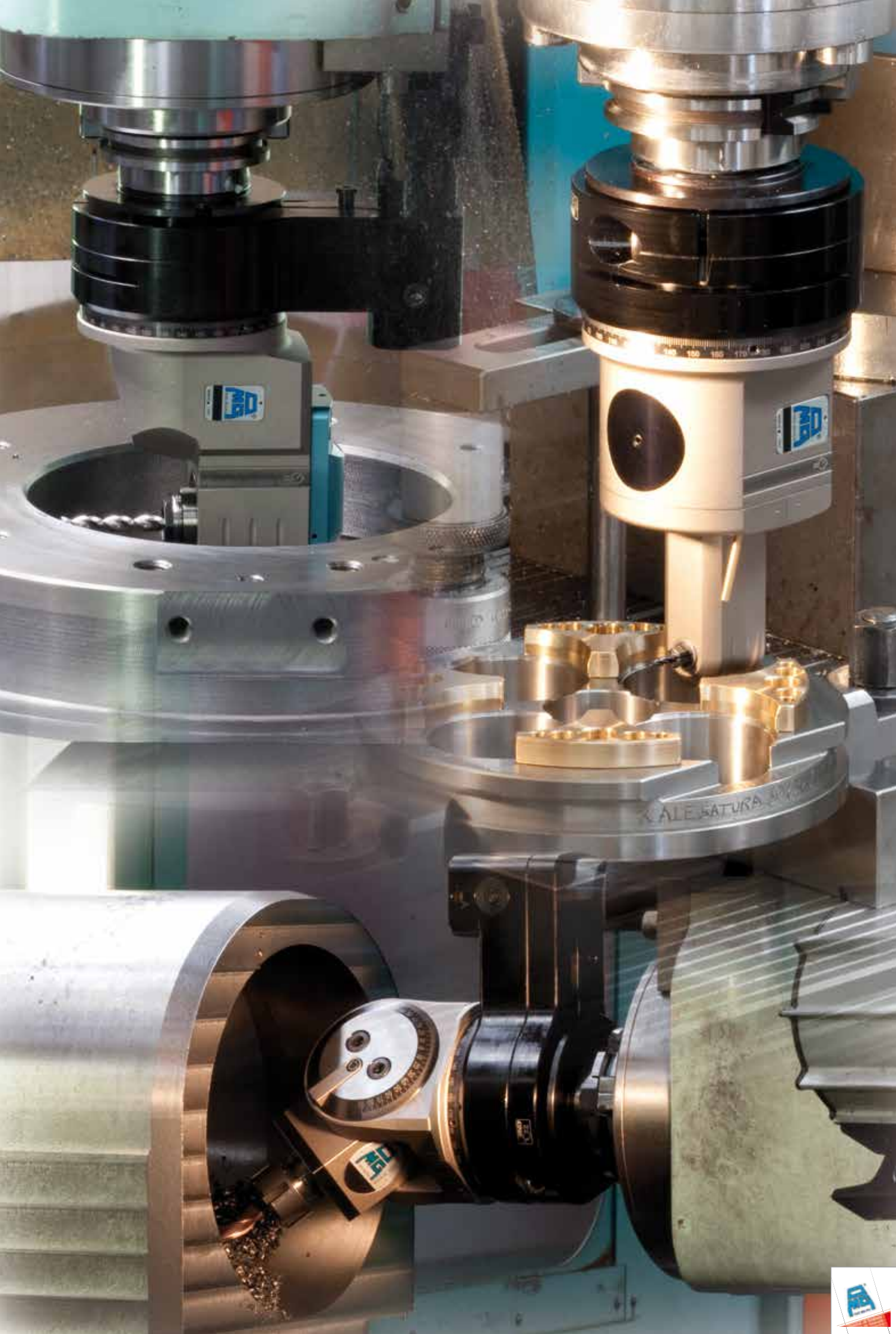

BAH

TA.CP

TA

MO

HT

VH

TSI/TSX

T

MT-TC-TC3

Accessori
Accessories

Appendice tecnica
Technical supplement



testa ad angolo - angle head

TAR03.P

caratteristiche/features



ø 3



M3



1-1



8000

peso/weight



6,7 kg



9,1 kg

rotazione/rotation



input



output

prestazioni/performance

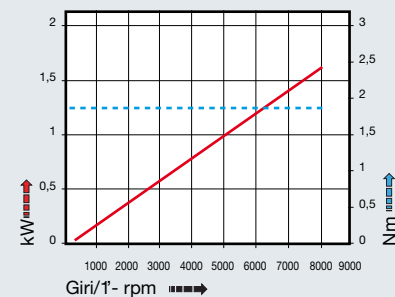

Giri/T' - rpm

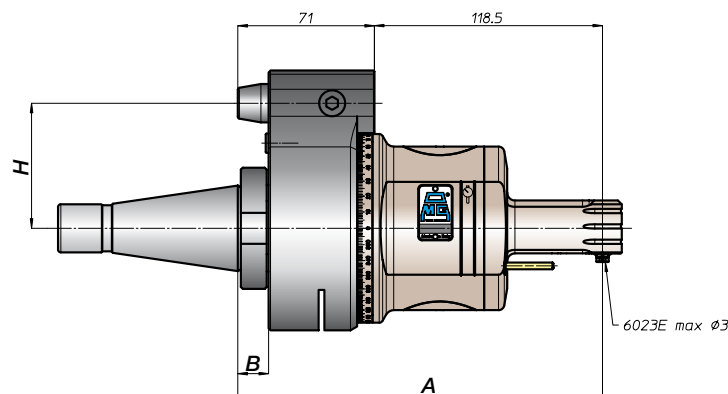
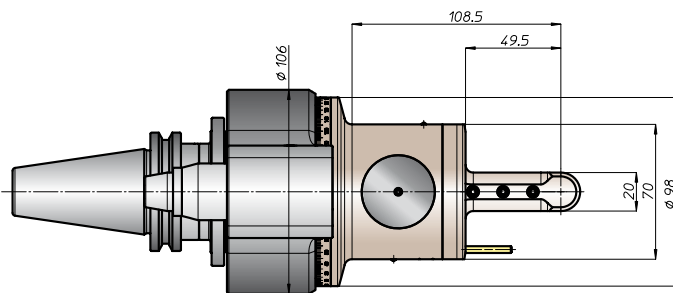
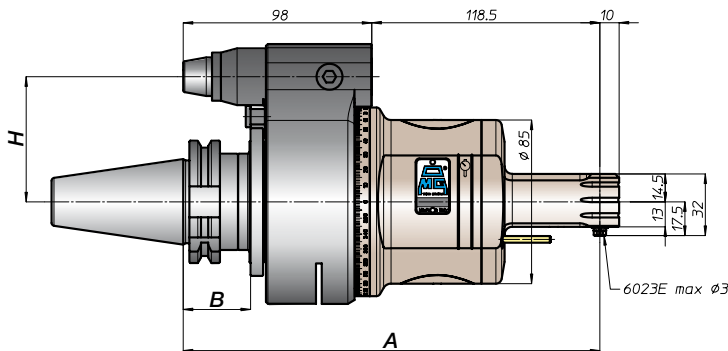
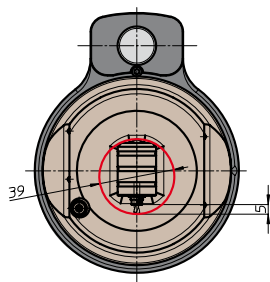

CONO SHANK	size	H			
		A	B	standard	optional
* DING9871	30	216,5	35	65	-
	40			80	110
	45			80	110
	50			80	110
* ANSIB5.50 CAT	40	216,5	35	65	-
	50			80	110
* BT	40	216,5	35	65	-
	50			80	110
HSK DING9893	63	225,5	46	65	-
	80			80	110
	100			80	110
CAPTO ISO26623	C5	220,5	39	65	-
	C6			80	110
	C8			80	110
KM	63	216,5	35	65	-
	80			80	110
	100			80	110
DIN2080	40	186,5	13	65	-
	50			80	110
ANSIB5.18 NMTB	40	186,5	13	65	-
	50			80	110

* Option: Dual Contact

BAH

TA-CP

TA

MO

HT

VH

TSI/TSX

T

MT-TC-TC3

Accessori
Accessories

Appendice tecnica
Technical supplement



TAR03.PL

caratteristiche/features

peso/weight

prestazioni/performance

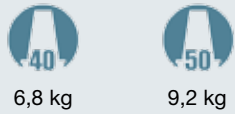

rotazione/rotation

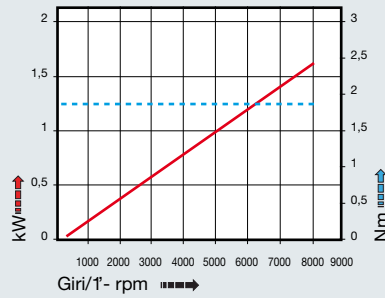

CONO SHANK	size	A	B	H	
				standard	optional
* DING69871 *	30	247,5	35	65	-
	40			80	110
	45			80	110
	50			80	110
* ANSIB5.50 * CAT	40	255,5	45	65	-
	50			80	110
* BT	40	255,5	45	65	-
	50			80	110
DING69893 HSK	63	256,5	44	65	-
	80		46	80	110
	100		46	80	110
ISO26623 CAPTO	C5	251,5	39	65	-
	C6			80	110
	C8			80	110
KM	63	247,5	13	65	-
	80			80	110
	100			80	110
DIN2080	-	217,5	13	65	-
	40	220,5	16	80	110
	50			80	110
ANSIB5.18 NMTB	40	217,5	13	65	-
	50	220,5	16	80	110

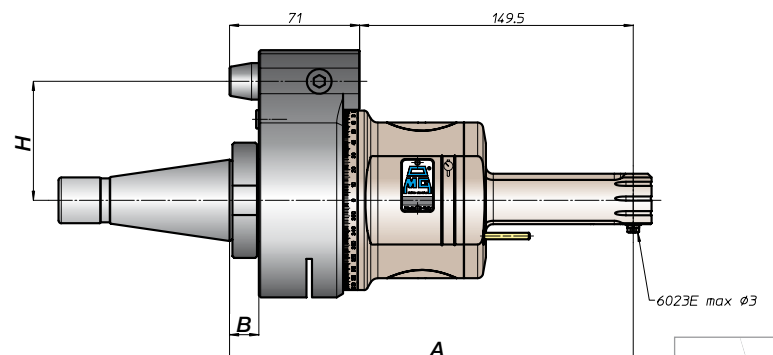
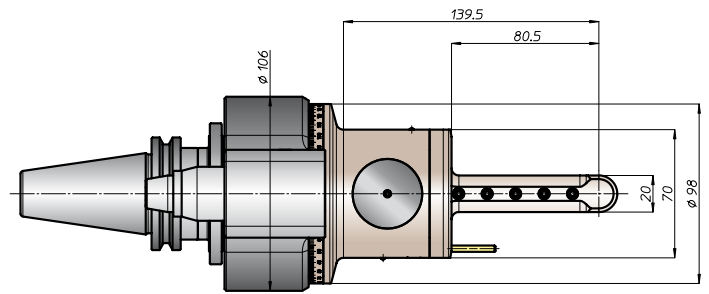
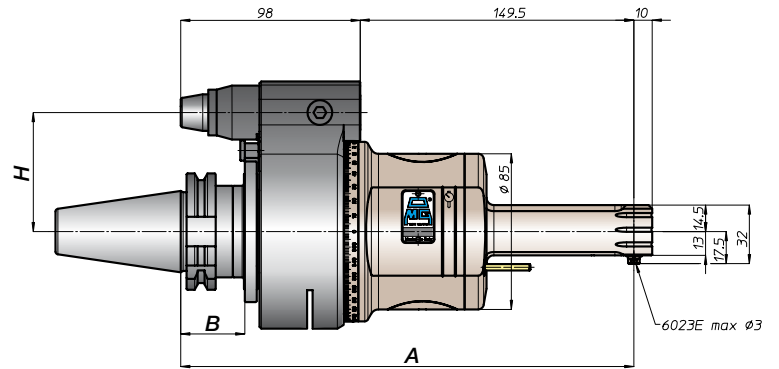
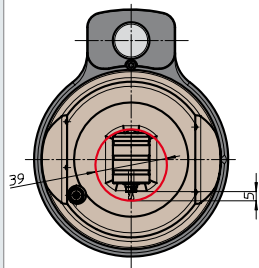

* Option: Dual Contact



BAH
TA.CP
TA
MO
HT
VH
TSI/TSX
T
MT-TC-TC3
Accessori
Accessories
Appendice tecnica
Technical supplement

testa ad angolo - angle head

TAR04.P



caratteristiche/features



ø 4



M3



1-1



8000

peso/weight



7 kg



9,4 kg

rotazione/rotation



input



output

prestazioni/performance

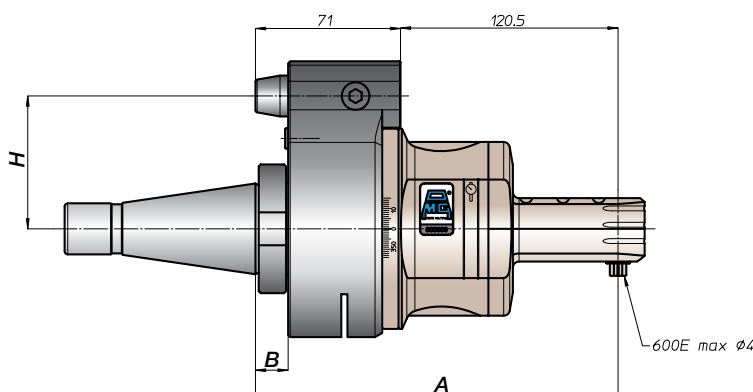
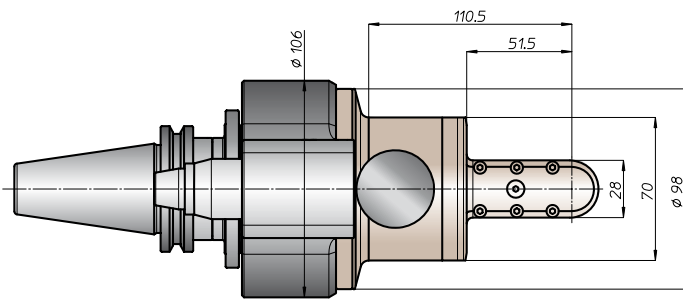
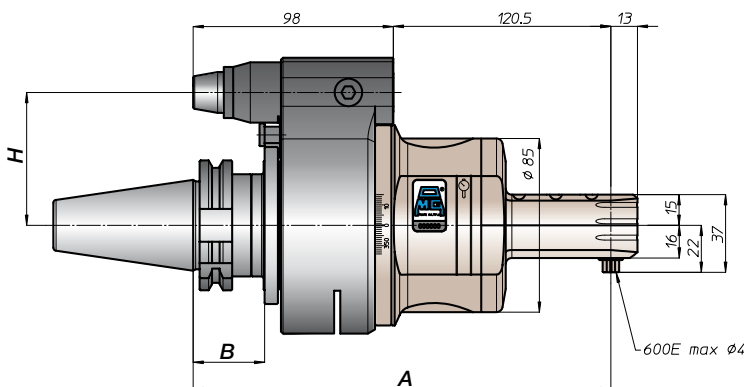
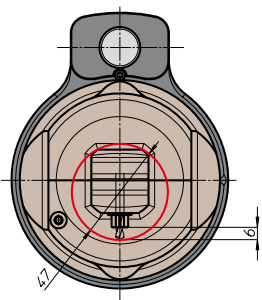
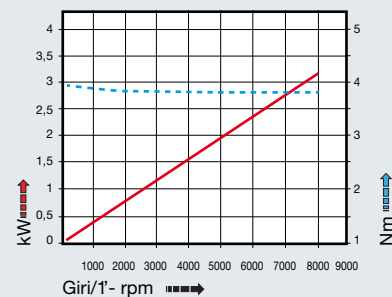

CONO SHANK	size	H			
		A	B	standard	optional
* DING9871	30			65	-
	40			80	110
	45			80	110
* ANSIB5.50 CAT	40	218,5	35	65	-
	50	218,5	35	80	110
* BT	40			65	
	50	226,5	45	80	110
DING9893 HSK	63		44	65	
	80	227,5		80	110
	100		46	80	110
ISO28623 CAPTO	C5			65	
	C6	222,5	39		
	C8			80	110
KM	63			65	
	80	218,5		80	110
	100			80	110
DIN2080	-	188,5	13	65	-
	40			80	110
ANSIB5.18 NMTB	-	191,5	16	80	110
	50			80	110
ANSIB5.18 NMTB	40	188,5	13	65	-
	50	191,5	16	80	110

* Option: Dual Contact

BAH

TA-CP

TA

MO

HT

VH

TSI/TSX

T

MT-TC-TC3

Accessori
Accessories

Appendice tecnica
Technical supplement



TAR04.PL

caratteristiche/features

peso/weight

prestazioni/performance

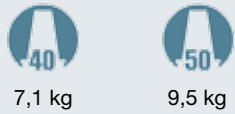

rotazione/rotation

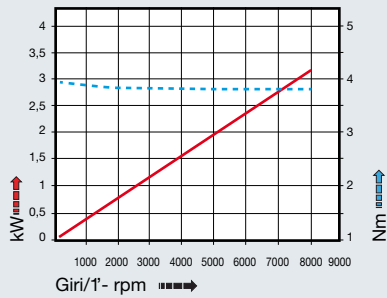

CONO SHANK	size	A	B	H	
				standard	optional
* DING9871	30	257	35	65	-
	40			80	110
	45			80	110
	50			80	110
* ANSIB5.50 CAT	40	257	35	65	-
	50			80	110
* BT	40	265	45	65	-
	50			80	110
DING9893 HSK	63	266	44	65	-
	80			80	110
	100			80	110
ISO26623 CAPTO	C5	261	39	65	-
	C6			80	110
	C8			80	110
KM	63	257	35	65	-
	80			80	110
	100			80	110
DIN2080	-	227	13	65	-
	40			80	110
	50			80	110
ANSIB5.18 NMTB	40	230	16	65	-
	50			80	110

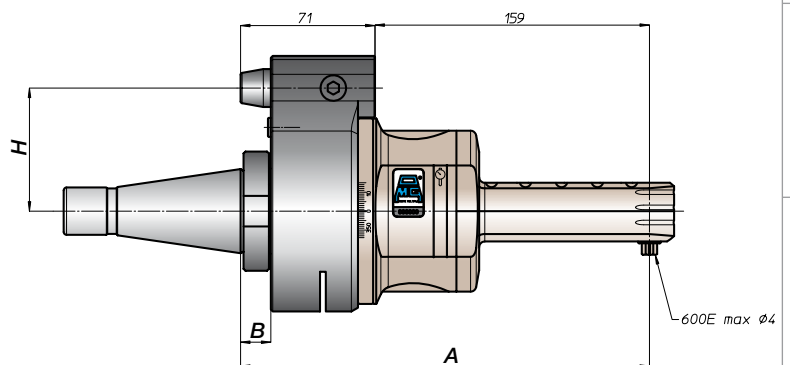
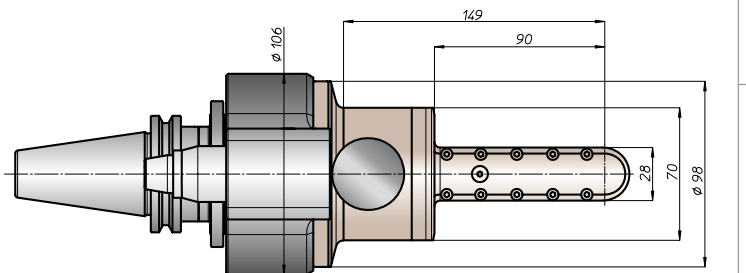
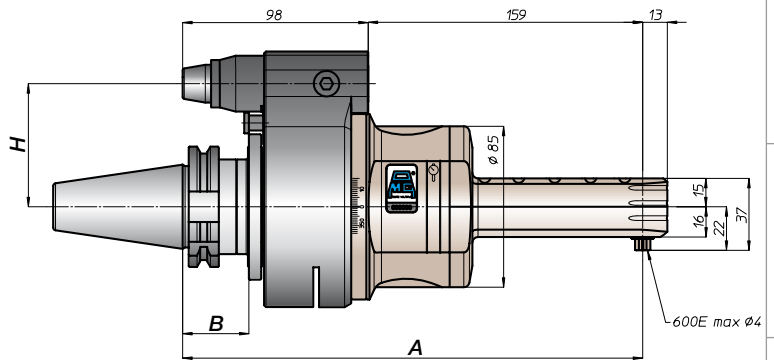
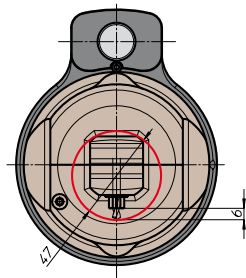

* Option: Dual Contact



BAH
TA.CP
TA
MO
HT
VH
TSI/TSX
T
MT-TC-TC3
Accessori
Accessories
Appendice tecnica
Technical supplement

testa ad angolo - angle head

TAR06.P



caratteristiche/features



ø 6



M5



1-1



8000

peso/weight



7,2 kg



9,6 kg

rotazione/rotation



input



output

prestazioni/performance

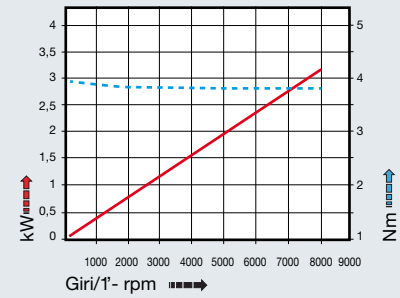

tipi mandrino disponibili / available spindle types

3 Weldon Whistle-Notch
Ø6

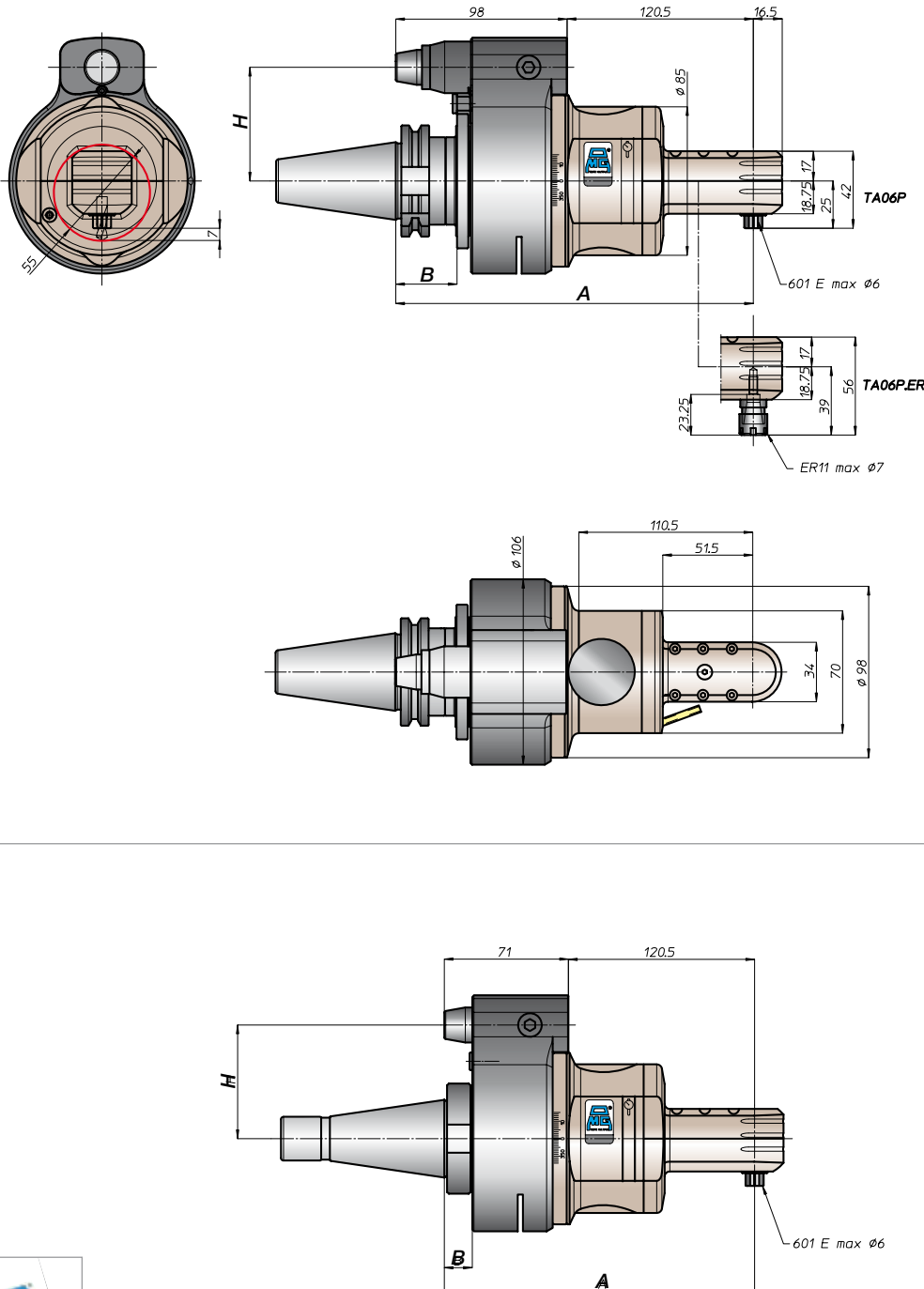

CONO SHANK	size	H			
		A	B	standard	optional
* DING9871	30	218,5	35	65	-
	40			80	110
	45			80	110
	50			80	110
* ANSIB5.50 CAT	40	218,5	35	65	-
	50			80	110
* BT	40	218,5	35	65	-
	50			80	110
HSK	63	227,5	46	44	65
	80			80	110
	100			80	110
CAPTO	C5	222,5	39	65	-
	C6			80	110
	C8			80	110
KM	63	218,5	35	65	-
	80			80	110
	100			80	110
DIN2080	-	188,5	13	65	-
	40			80	110
	-			191,5	16
ANSIB5.18 NMTB	40	188,5	13	65	-
	50			80	110

* Option: Dual Contact



TAR06.PL

caratteristiche/features

peso/weight

prestazioni/performance



rotazione/rotation

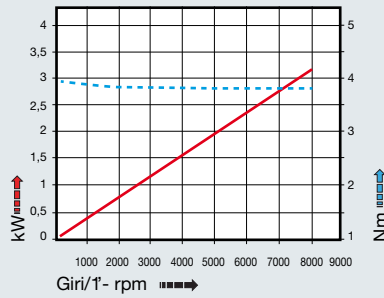

CONO SHANK	size	A	B	H	
				standard	optional
DIN9871 *	30	257	35	65	-
	40			80	110
	45			80	110
	50			80	110
ANSIB5.50 *	40	265	45	65	-
	50			80	110
* BT	40	265	45	65	-
	50			80	110
HSK	63	266	46	65	-
	80			80	110
	100			80	110
CAPTO	C5	261	39	65	-
	C6			80	110
	C8			80	110
KM	63	257	46	65	-
	80			80	110
	100			80	110
DIN2080	40	227	13	65	-
	50			80	110
	50			80	110
ANSIB5.18	40	230	16	65	-
	50			80	110

tipi mandrino disponibili / available spindle types

3 Weldon Whistle-Notch
Ø6

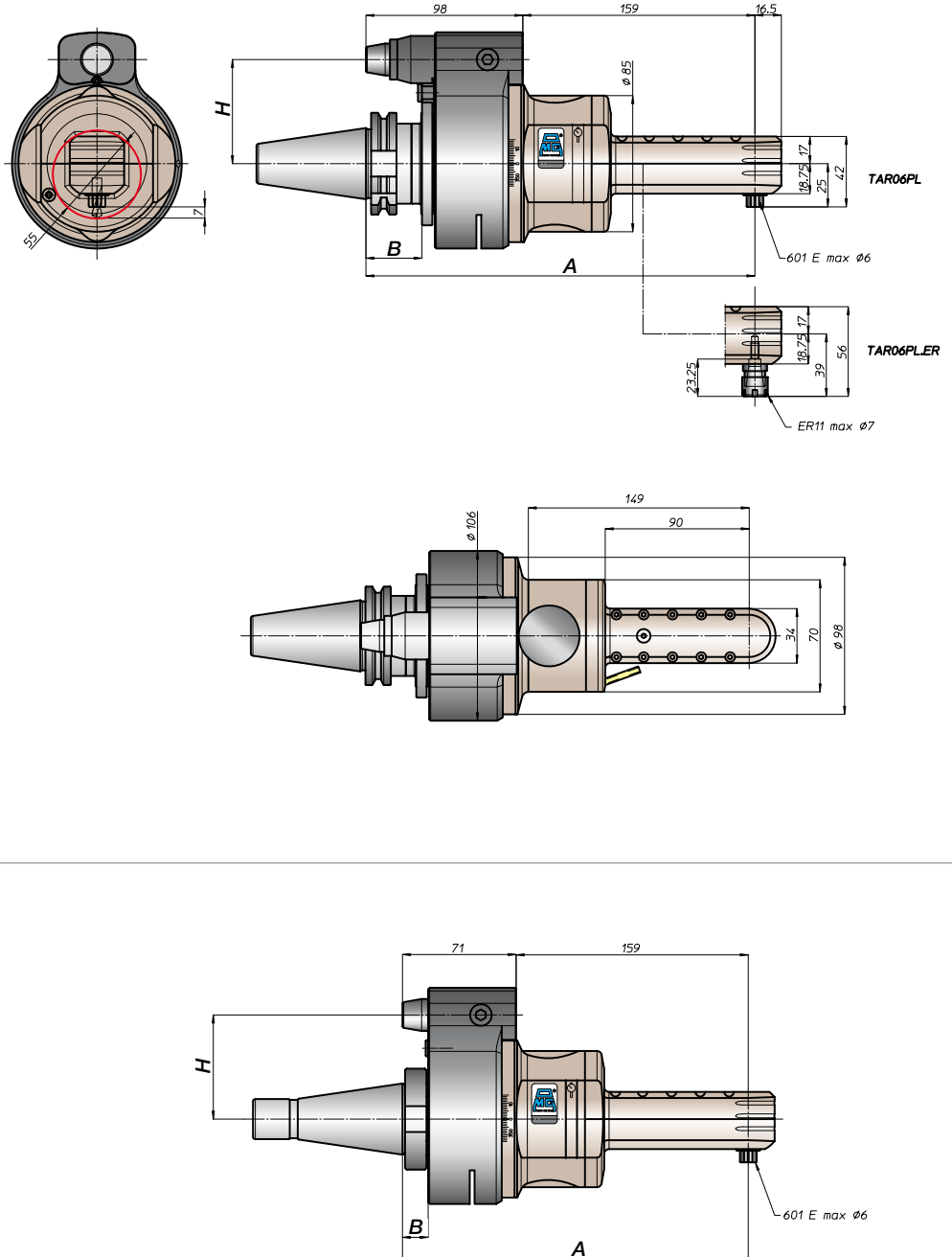

* Option: Dual Contact



BAH
TA.CP
TA
MO
HT
VH
TSI/TSX
T
MT-TC-TC3
Accessori
Accessories
Appendice tecnica
Technical supplement

testa ad angolo - angle head

TAR10.P



caratteristiche/features



ø 10



M8



1-1



6000

peso/weight



7 kg



9 kg

rotazione/rotation



input



output

prestazioni/performance

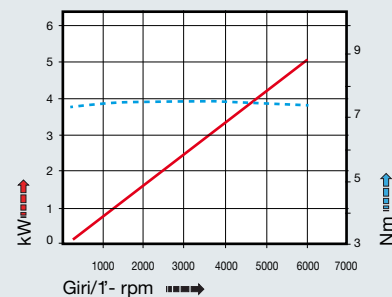

tipi mandrino disponibili / available spindle types

3 Weldon Whistle-Notch
Ø12

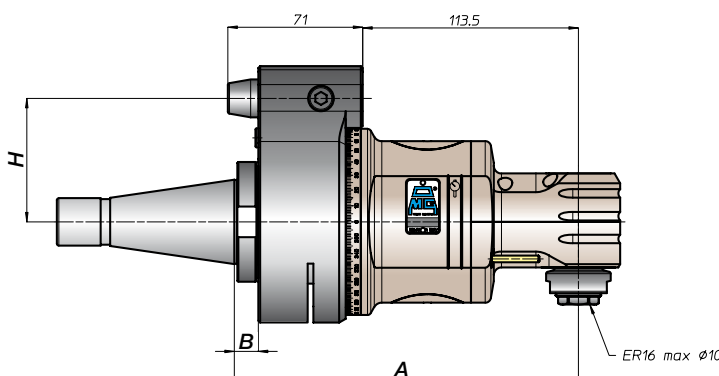
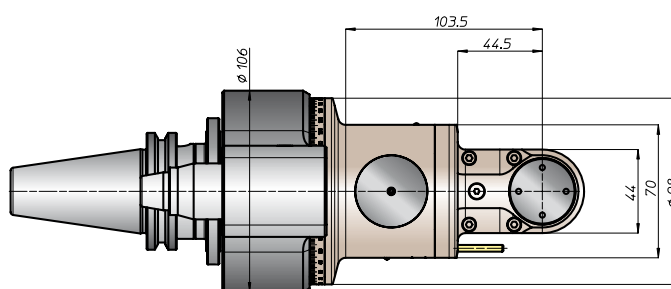
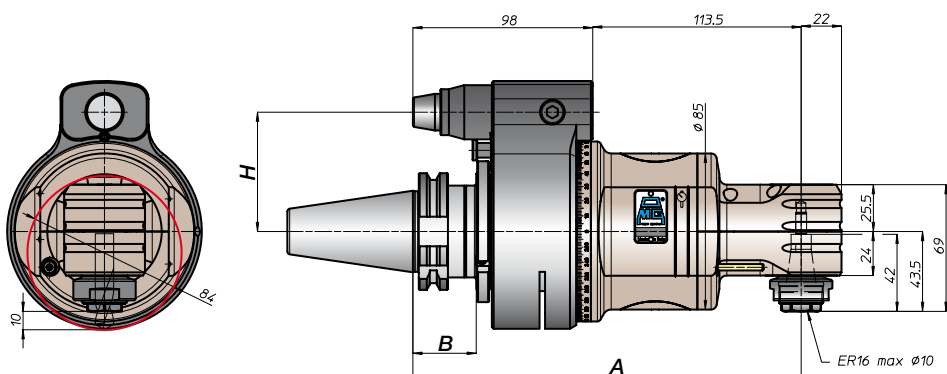

CONO SHANK	size	H			
		A	B	standard	optional
* DING9871	-			65	-
	40			80	110
	45			80	110
* CAT	40	211,5	35	65	-
	50	211,5	35	80	110
* BT	40			65	
	50	219,5	45	80	110
HSK	63		44	65	
	80	220,5		80	110
	100	220,5	46	80	110
CAPTO	C5			65	
	C6	215,5	39		
	C8	215,5		80	110
KM	63			65	
	80	211,5		80	110
	100	211,5		80	110
DIN2080	-	181,5	13	65	-
	40	181,5	13	80	110
	-	184,5	16	80	110
ANSIB5.18	40	181,5	13	65	-
	50	184,5	16	80	110

* Option: Dual Contact

BAH

TA-CP

TA

MO

HT

VH

TSI/TSX

T

MT-TC-TC3

Accessori
Accessories

Appendice tecnica
Technical supplement



TAR10.PL



caratteristiche/features

peso/weight

prestazioni/performance

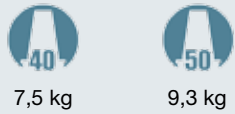

rotazione/rotation

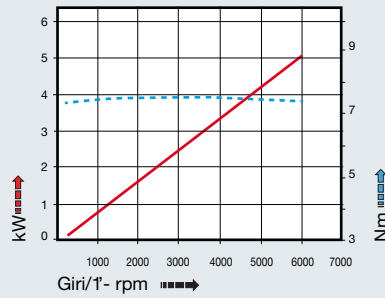
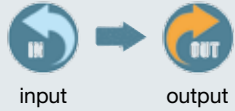

CONO SHANK	size	A	B	H	
				standard	optional
DING9871 *	40	243	35	65	-
	45			80	110
	50			80	110
ANSIB5.50 *	40	243	35	65	-
	50			80	110
* BT	40	251	45	65	-
	50			80	110
DING9893	63	252	44	65	-
	80			80	110
	100			80	110
ISO26623	C5	247	39	65	-
	C6			80	110
	C8			80	110
KM	63	243	35	65	-
	80			80	110
	100			80	110
DIN2080	40	213	13	65	-
	50	216	16	80	110
	50	216	16	80	110
ANSIB5.18	40	213	13	65	-
	50	216	16	80	110

tipi mandrino disponibili / available spindle types

3 Weldon Whistle-Notch Ø12

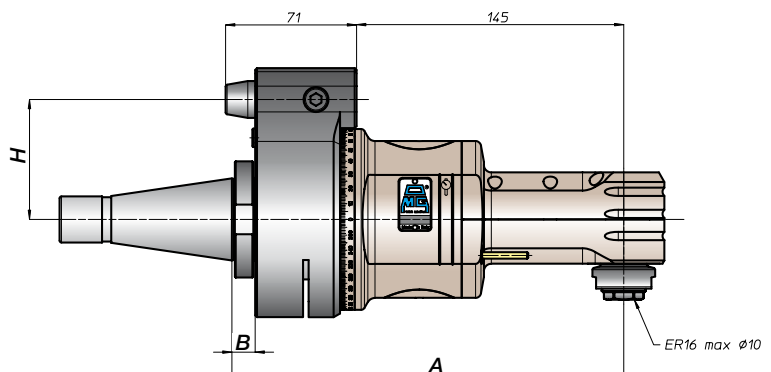
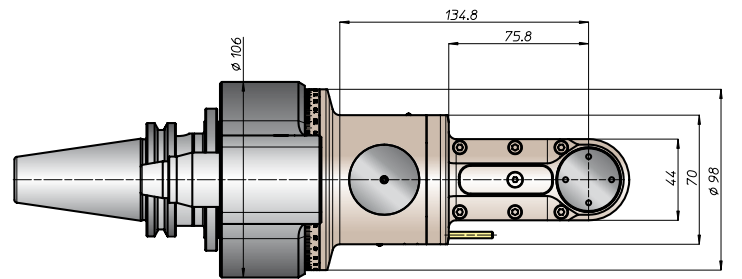
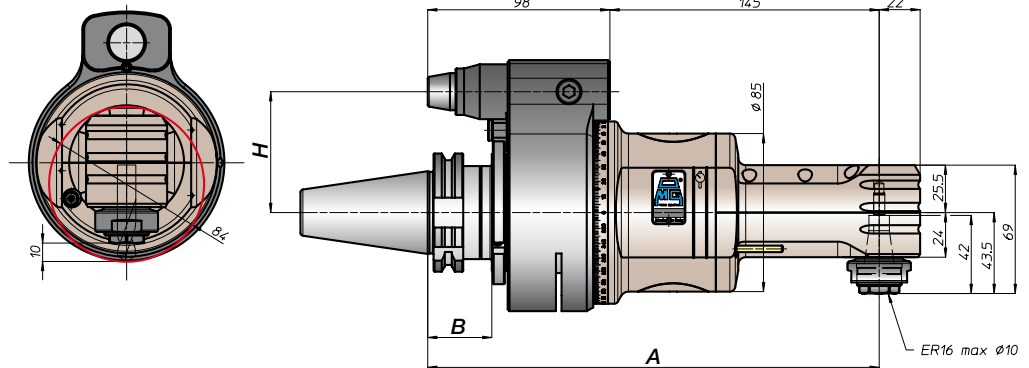

* Option: Dual Contact



BAH
TA.CP
TA
MO
HT
VH
TSI/TSX
T
MT-T-C3
Accessori
Accessories
Appendice tecnica
Technical supplement

testa ad angolo - angle head

TA07.P



caratteristiche/features



ø 7



M6



1-1



10000

peso/weight



5,5 kg



7,5 kg

rotazione/rotation



input



output

prestazioni/performance

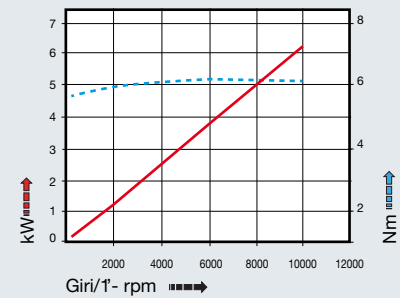

tipi mandrino disponibili / available spindle types

3 Weldon Whistle-Notch
Ø8-Ø10

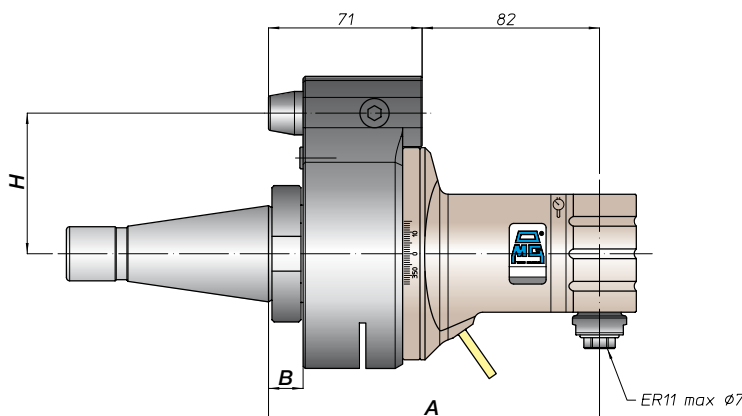
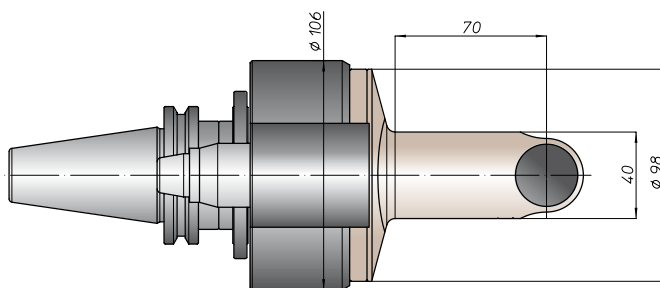
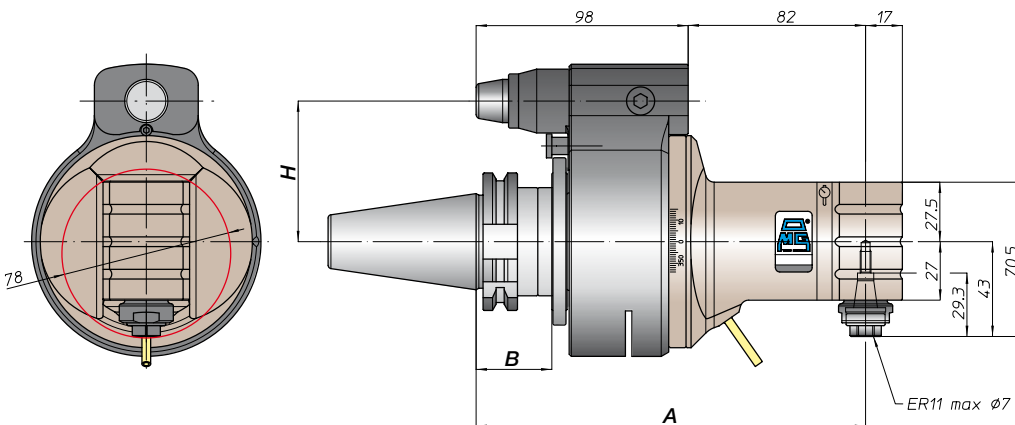

CONO SHANK	size	H			
		A	B	standard	optional
* DING9871	30	180	35	65	-
	40			80	110
	45			80	110
	50			80	110
* ANSIB5.50 CAT	40	180	35	65	-
	50			80	110
* BT	40	180	35	65	-
	50			80	110
HSK DING9893	63	189	46	44	65
	80			80	110
	100			80	110
ISO28623 CAPTO	C5	184	39	65	-
	C6			80	110
	C8			80	110
KM	63	180	35	65	-
	80			80	110
	100			80	110
DIN2080	-	150	13	65	-
	40			80	110
	-			153	16
ANSIB5.18 NMTB	40	150	13	65	-
	50			153	16

* Option: Dual Contact

BAH

TA-CP

TA

MO

HT

VH

TSI/TSX

T

MT-TC-TC3

Accessori
Accessories

Appendice tecnica
Technical supplement



TA07.PL

caratteristiche/features

peso/weight

prestazioni/performance

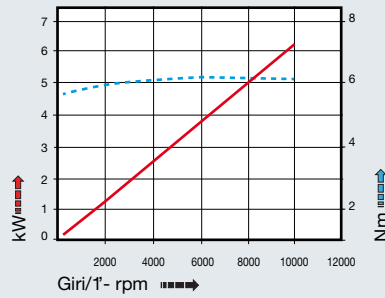
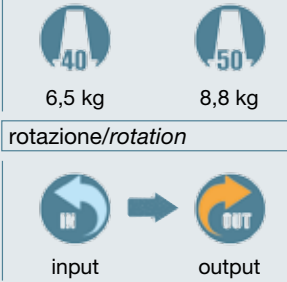

CONO SHANK	size	A	B	H	
				standard	optional
DING9871 *	-	250	35	65	-
	40			80	110
	45			80	110
ANSIB5.50 *	CAT	258	45	65	-
	BT			80	110
DING9893	HSK	259	44	65	-
	80			80	110
	100			80	110
ISO26623	C5	254	39	65	-
	C6			80	110
	C8			80	110
KM	63	250	13	65	-
	80			80	110
	100			80	110
DIN2080	-	220	13	65	-
	40			80	110
	50			80	110
ANSIB5.18	NMTB	223	16	65	-
	50			80	110

tipi mandrino disponibili / available spindle types

3 Weldon Whistle-Notch
Ø8-Ø10

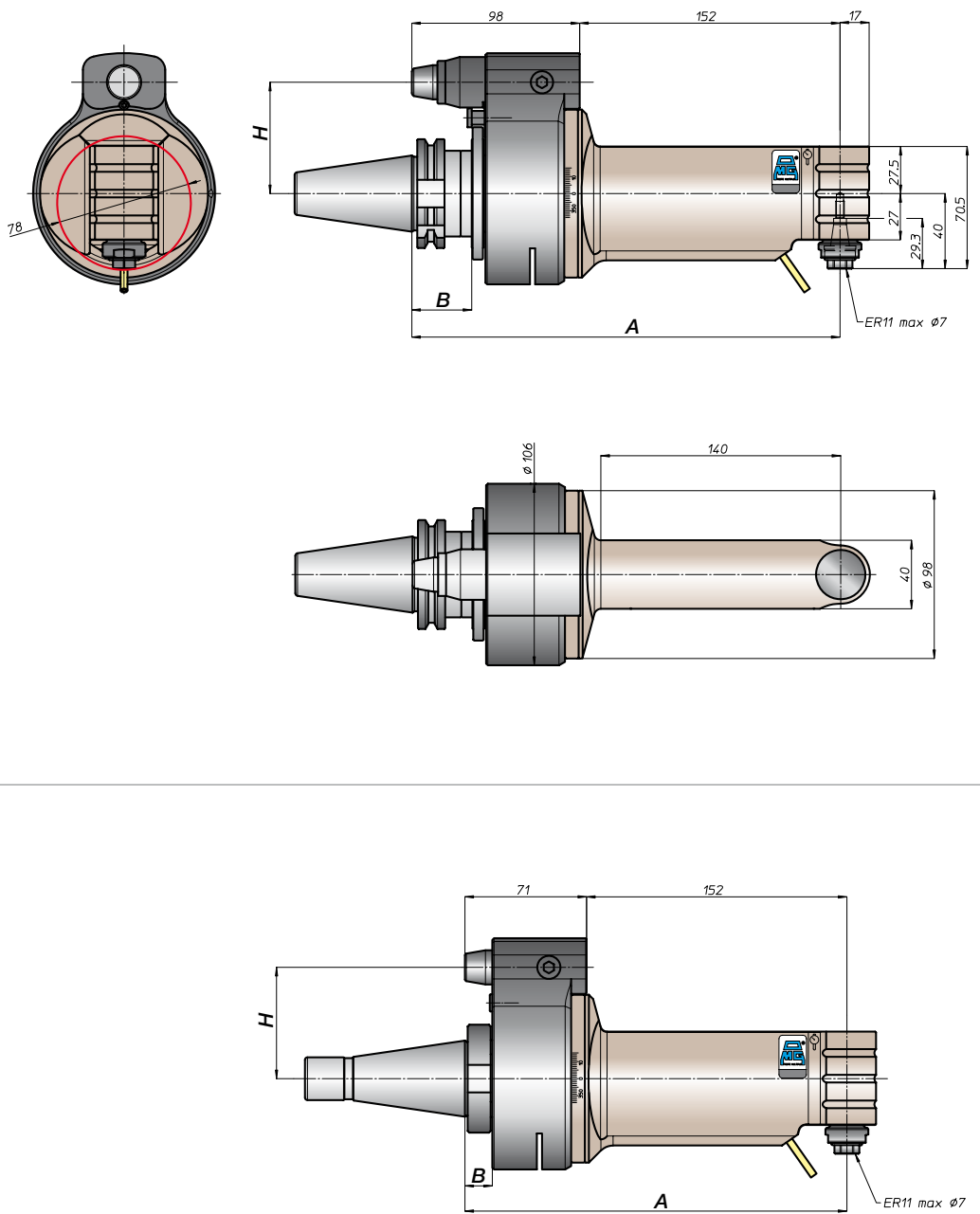

* Option: Dual Contact



BAH
TA.CP
TA
MO
HT
VH
TSI/TSX
T
MT-TC-TC3
Accessori
Accessories
Appendice tecnica
Technical supplement

testa ad angolo - angle head

TA10.P



caratteristiche/features



peso/weight



rotazione/rotation



prestazioni/performance

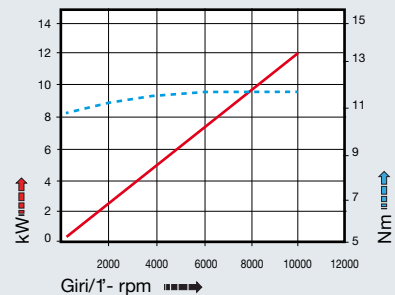

tipi mandrino disponibili / available spindle types

- 1** DIN6388-ER **ER20**
- 2** Albero portafrese Milling shaft **Ø16**
- 3** Weldon Whistle-Notch **Ø10**

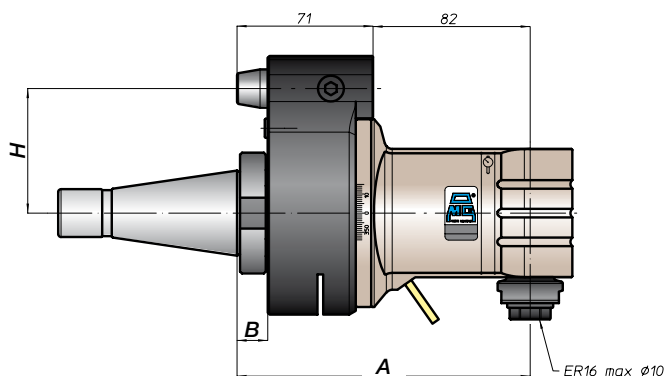
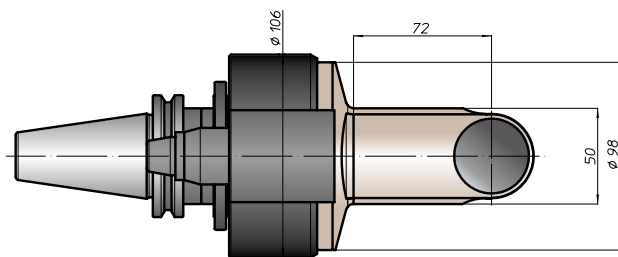
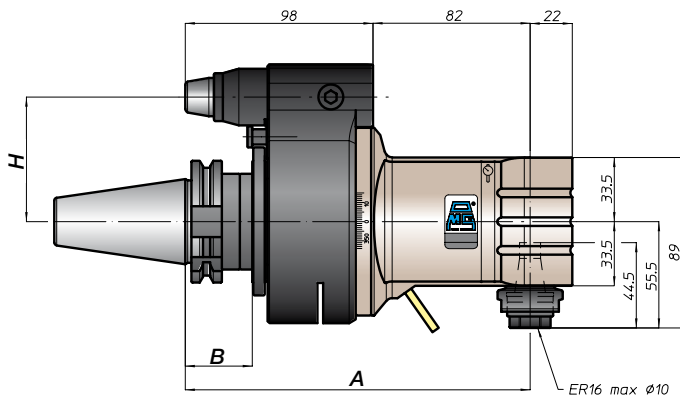
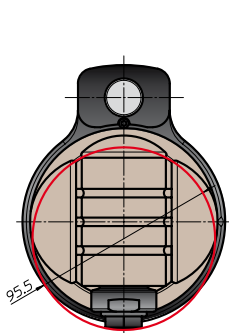

CONO SHANK	size	H			
		A	B	standard	optional
* DIN69871	30	180	35	65	-
	40			80	110
	45			80	110
	50			80	110
* ANSIB5.50 CAT	40	188	45	65	-
	50			80	110
* BT	40	188	45	65	-
	50			80	110
DIN69893 HSK	63	189	46	65	-
	80			80	110
	100			80	110
ISO28623 CAPTO	C5	184	39	65	-
	C6			80	110
	C8			80	110
KM	63	180	13	65	-
	80			80	110
	100			80	110
DIN2080	40	153	16	65	-
	50			80	110
ANSIB5.18 NMTB	40	150	13	65	-
	50			80	110

* Option: Dual Contact



TA10.PL



caratteristiche/features

peso/weight

prestazioni/performance

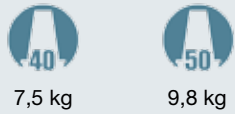

rotazione/rotation

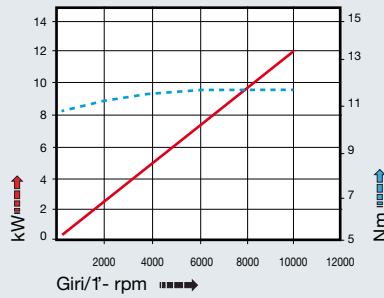

CONO SHANK	size	A	B	H	
				standard	optional
DING9871 *	-	250	35	65	-
	40			80	110
	45			80	110
ANSIB5.50 *	CAT	250	35	65	-
				80	110
BT *	40	258	45	65	-
	50			80	110
HSK	63	259	44	65	-
	80			80	110
	100			80	110
CAPTO	C5	254	39	65	-
	C6			80	110
	C8			80	110
KM	63	250	35	65	-
	80			80	110
	100			80	110
DIN2080	-	220	13	65	-
	40			80	110
	50			80	110
NMTB	40	220	13	65	-
	50			80	110

tipi mandrino disponibili / available spindle types

- 1** DIN6388-ER **ER20**
- 2** Albero portafresa Milling shaft **Ø16**
- 3** Weldon Whistle-Notch **Ø10**

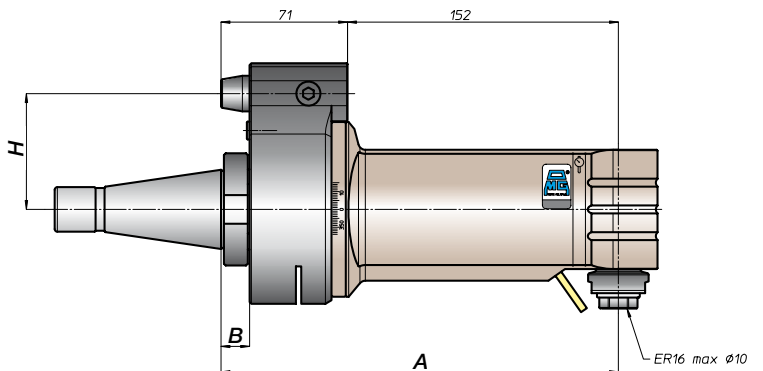
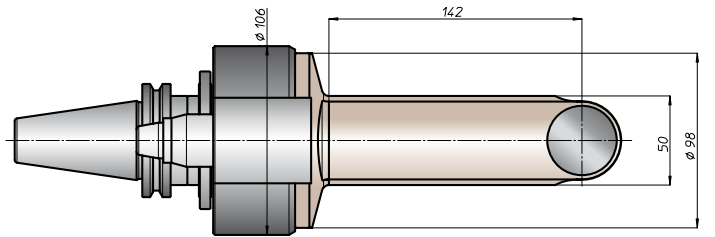
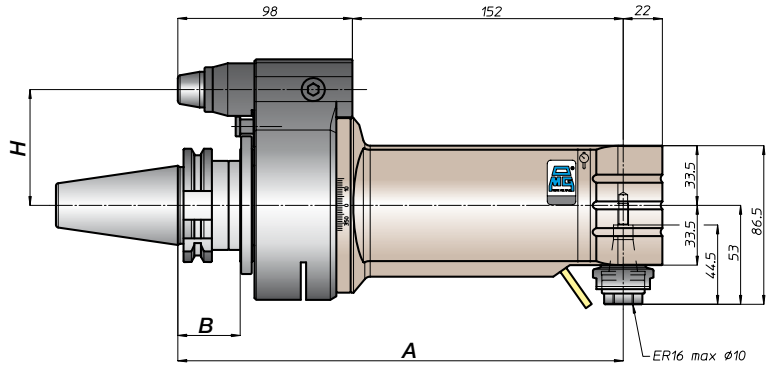
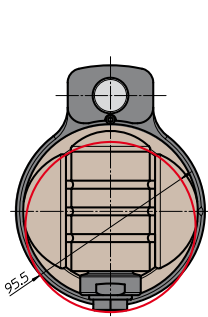

* Option: Dual Contact

BAH
TA.CP
TA
MO
HT
VH
TSI/TSX
T
MT-TC-TC3
Accessori
Accessories
Appendice tecnica
Technical supplement

testa ad angolo - angle head

TA13.P



caratteristiche/features



ø 13



M10



1-1



8000

peso/weight



6,5 kg



9 kg

rotazione/rotation



input



output

prestazioni/performance

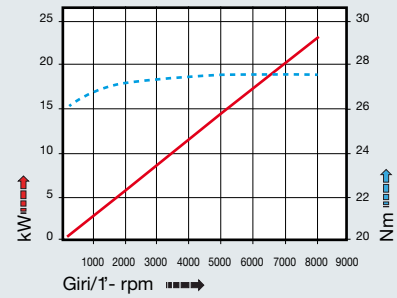

tipi mandrino disponibili / available spindle types

- 1** DIN6388-ER
ER25
- 2** Albero portafresse
Milling shaft
Ø16-Ø22
- 3** Weldon
Whistle-Notch
Ø16

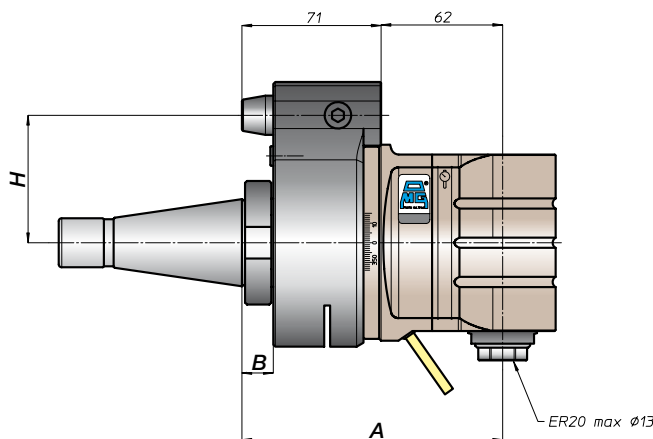
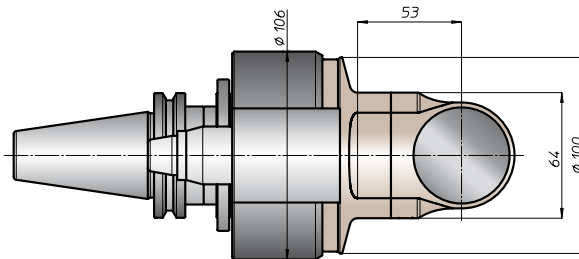
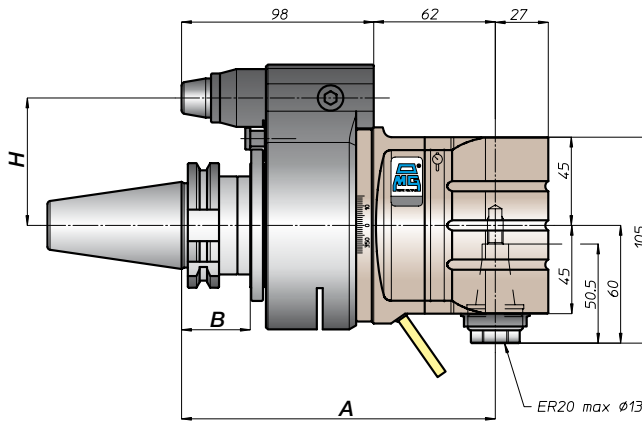
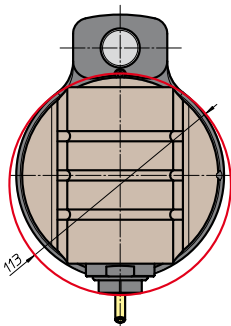

CONO SHANK	size	H			
		A	B	standard	optional
* DIN69871	-			65	-
	40	160	35	80	110
	45			80	110
50	80			110	
* CAT	40			65	-
	50			80	110
* BT	40			65	
	50	168	45	80	110
HSK	63		44	65	
	80	169	46	80	110
	100			80	110
CAPTO	C5			65	
	C6	164	39	80	110
	C8			80	110
KM	63			65	
	80	160		80	110
	100			80	110
DIN2080	-	130	13	65	-
	40	133	16	80	110
	50			80	110
NMTB	40	130	13	65	-
	50	133	16	80	110

* Option: Dual Contact

BAH

TA-CP

TA

MO

HT

VH

TSI/TSX

T

MT-TC-TC3

Accessori
Accessories

Appendice tecnica
Technical supplement



TA13.PL



caratteristiche/features

peso/weight

prestazioni/performance



rotazione/rotation

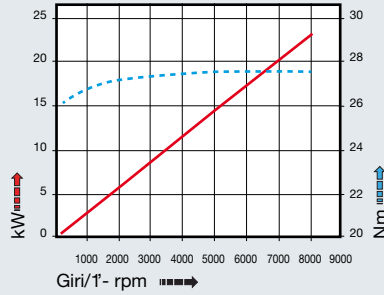
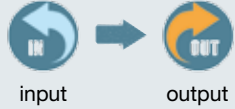

CONO SHANK	size	A	B	H	
				standard	optional
* DING9871 *	-	260	35	65	-
	40			80	110
	45			80	110
* ANSIB5.50 *	40	268	45	65	-
	50			80	110
* BT	40	268	45	65	-
	50			80	110
DING9893	63	269	46	65	-
	80			80	110
	100			80	110
ISO26623	C5	264	39	65	-
	C6			80	110
	C8			80	110
KM	63	260	46	65	-
	80			80	110
	100			80	110
DIN2080	-	230	13	65	-
	40			80	110
	50			80	110
ANSIB5.18	40	233	16	65	-
	50			80	110

tipi mandrino disponibili / available spindle types

- 1** DIN6388-ER **ER25**
- 2** Albero portafresa Milling shaft **Ø16-Ø22**
- 3** Weldon Whistle-Notch **Ø16**

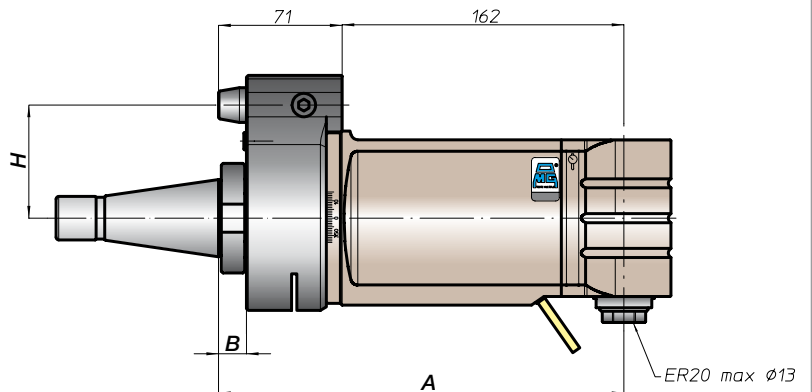
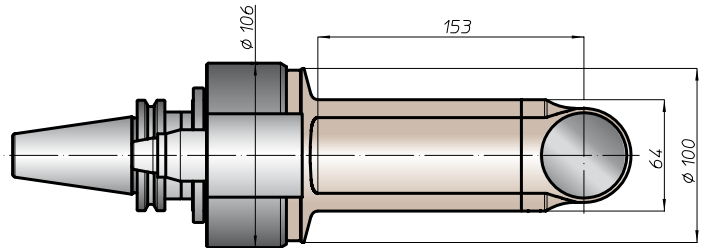
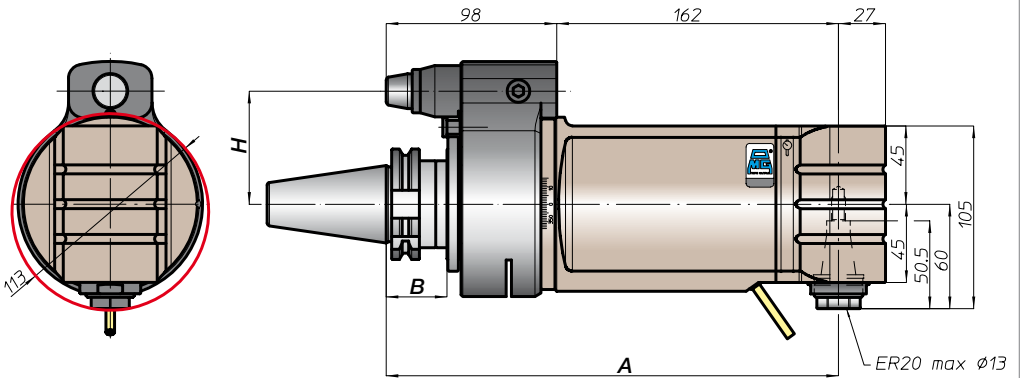

* Option: Dual Contact



BAH
TA.CP
TA
MO
HT
VH
TSI/TSX
T
MT-TC-TC3
Accessori
Accessories
Appendice tecnica
Technical supplement

TA16.P



caratteristiche/features



ø 16



M12



1-1



5000

peso/weight



7,7 kg



11,7 kg

rotazione/rotation



input



output

prestazioni/performance

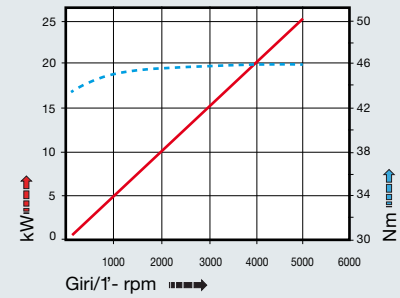

tipi mandrino disponibili / available spindle types

- 1** DIN6388-ER
ER32
- 2** Albero portafresse
Milling Shaft
Ø16-Ø22-Ø27-Ø32
- 3** Weldon
Whistle-Notch
Ø20
- 4** DIN69893-HSK
HSK32
- 5** COROMANT
CAPTO®
C3
- 6** ABS
Licenza KOMET®
ABS32

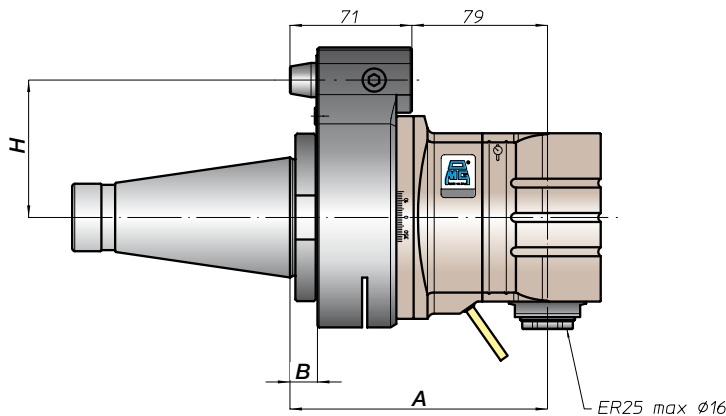
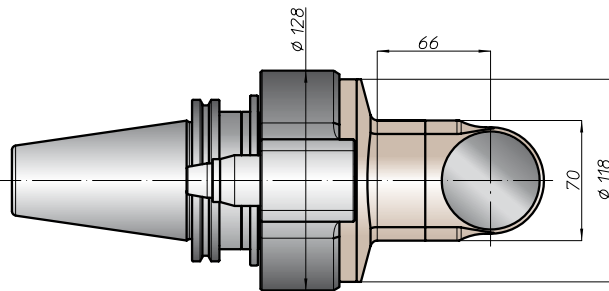
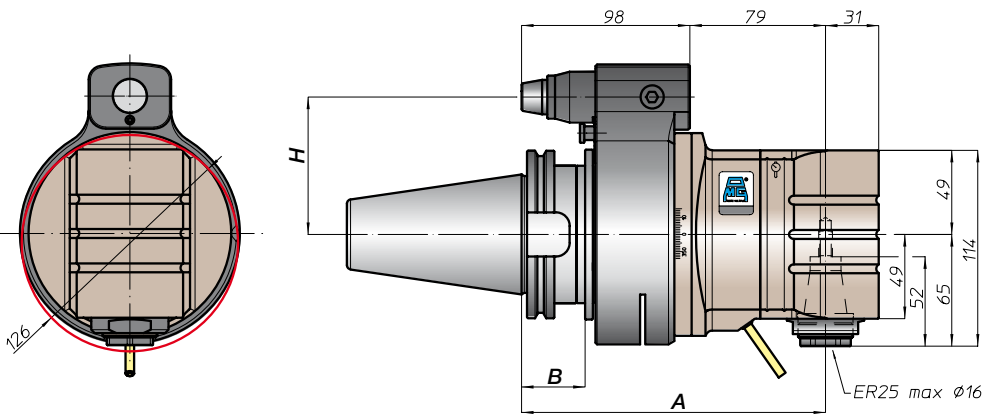

CONO SHANK	size	H			
		A	B	standard	optional
* DIN69871	-	172		65	-
	40				
	45			80	110
* CAT	40	172	35	65	-
	50	177		80	110
* BT	40	172		65	
	50	185	45	80	110
HSK	63	181	44	65	
	80				
	100	186	46	80	110
CAPTO	C5	176		65	
	C6		39		
	C8	181		80	110
KM	63	172		65	
	80				
	100	177		80	110
DIN2080	-	147	13	65	-
	40				
	50	150	16	80	110
NMTB	40	142	13	65	-
	50	150	16	80	110

* Option: Dual Contact

BAH

TA-CP

TA

MO

HT

VH

TSI/TSX

T

MT-TC-TC3

Accessori
Accessories

Appendice tecnica
Technical supplement



TA16.PL



caratteristiche/features

peso/weight

prestazioni/performance



15,5 kg

rotazione/rotation

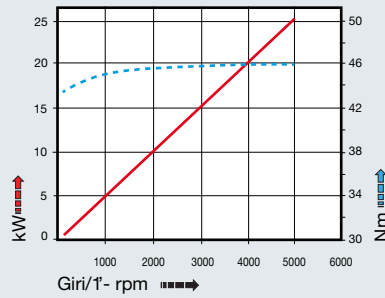
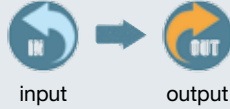

CONO SHANK	size	A	B	H	
				standard	optional
* DING9871	-	-	-	-	-
	45	277	35	80	110
	50	277	35	80	110
* ANSIB5.50 CAT	-	-	-	-	-
	50	277	-	80	110
* BT	-	-	-	-	-
	50	285	45	80	110
HSK DING9893	-	-	-	-	-
	80	286	46	80	110
	100	286	46	80	110
CAPTO ISO26623	-	-	-	-	-
	C6	281	39	80	110
	C8	281	39	80	110
KM	-	-	-	-	-
	80	277	-	80	110
	100	277	-	80	110
DIN2080	-	-	-	-	-
	50	250	16	80	110
ANSIB5.18 NMTB	-	-	-	-	-
	50	250	16	80	110

tipi mandrino disponibili / available spindle types

- 1 DIN6388-ER
ER32
- 2 Albero portafresa
Milling shaft
Ø16-Ø22-Ø27-Ø32
- 3 Weldon
Whistle-Notch
Ø20
- 4 DIN69893-HSK
HSK32
- 5 COROMANT
CAPTO®
C3
- 6 ABS
Licenza KOMET®
ABS32

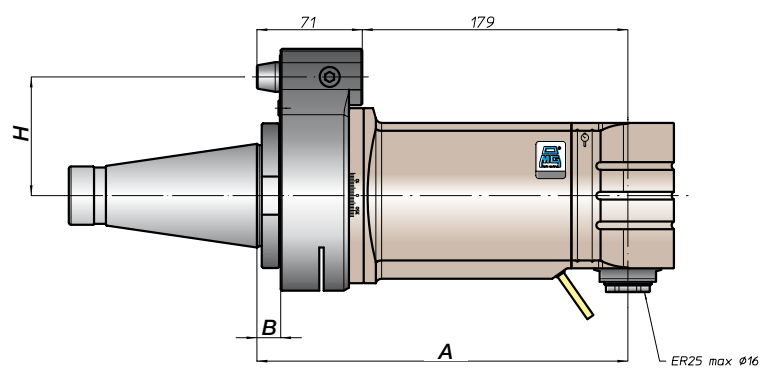
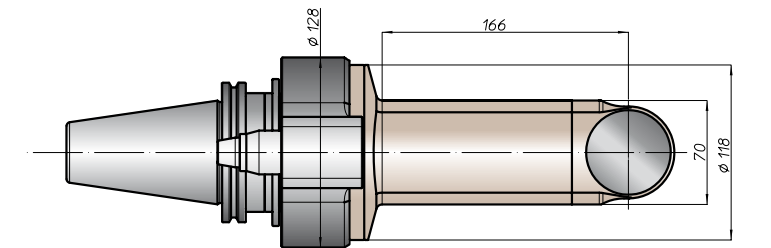
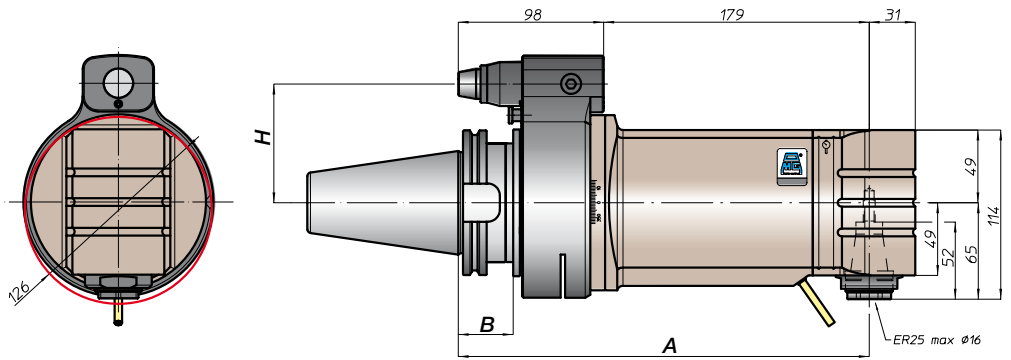

* Option: Dual Contact



BAH
 TA.CP
 TA
 MO
 HT
 VH
 TSI/TSX
 T
 MT-TC-TC3
 Accessori
 Accessories
 Appendice tecnica
 Technical supplement

testa ad angolo - angle head

TA20.P



caratteristiche/features



ø 20



M14



1-1



3500

peso/weight



14,5 kg

rotazione/rotation



input



output

prestazioni/performance

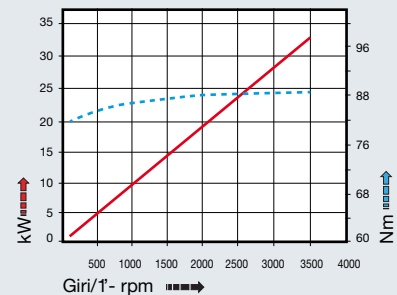

tipi mandrino disponibili / available spindle types

- 1** DIN6388-ER
ER40
- 2** Albero portafrese
Milling shaft
Ø22-Ø27-Ø32
- 3** Weldon
Whistle-Notch
Ø20-Ø25-Ø32
- 4** DIN69893-HSK
HSK40
- 5** COROMANT
CAPTO®
C4
- 6** ABS
Licenza KOMET®
ABS40

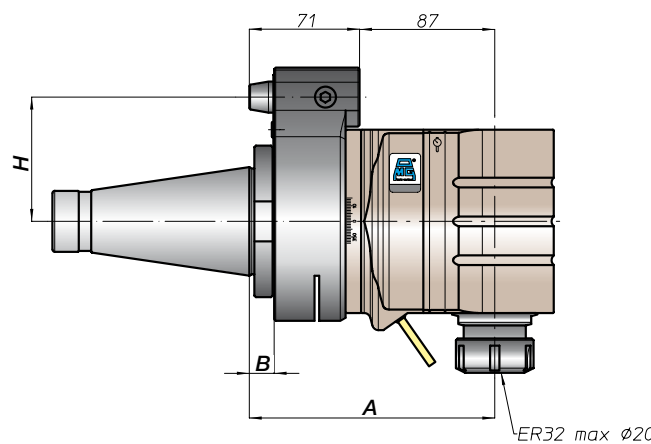
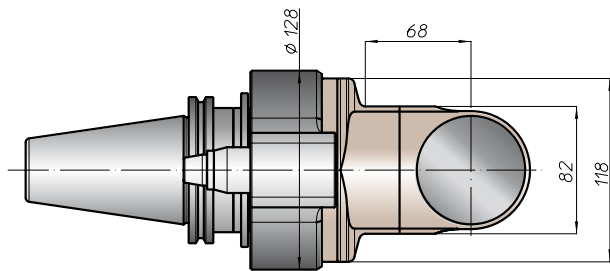
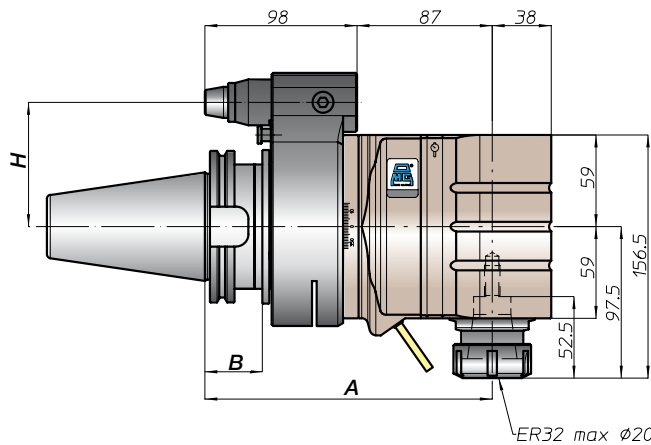
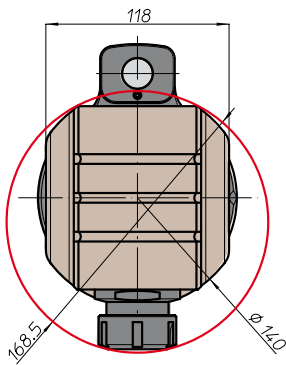

CONO SHANK	size	H			
		A	B	standard	optional
DIN69871 *	-	-	-	-	-
DIN69871 *	45	-	-	80	110
DIN69871 *	50	185	35	80	110
ANSIB5.50 *	-	-	-	-	-
ANSIB5.50 *	50	-	-	80	110
BT *	-	-	-	-	-
BT *	50	193	45	80	110
HSK	-	-	-	-	-
DIN69893	80	194	-	80	110
DIN69893	100	-	46	80	110
CAPTO	-	-	-	-	-
ISO28623	-	189	-	80	110
ISO28623	C8	-	-	80	110
KM	-	-	-	-	-
KM	80	185	-	80	110
KM	100	-	-	80	110
DIN2080	-	-	-	-	-
DIN2080	-	-	-	-	-
DIN2080	50	158	16	80	110
NMTB	-	-	-	-	-
ANSIB5.18	50	158	16	80	110

* Option: Dual Contact



TA20.PL



caratteristiche/features

peso/weight

prestazioni/performance



19 kg

rotazione/rotation



input



output

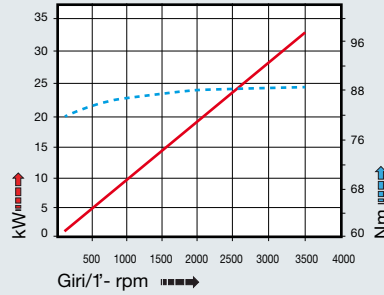

CONO SHANK	size	A	B	H	
				standard	optional
* DING9871	-	260	35	-	-
	45			80	110
* ANSIB5.50	-	264	46	-	-
	50			80	110
* BT	-	268	45	-	-
	50			80	110
HSK DING9893	-	269	46	-	-
	80			80	110
CAPTO ISO26623	-	264	46	-	-
	80			80	110
KM	-	260	46	-	-
	80			80	110
DIN2080	-	233	16	-	-
	50			80	110
ANSIB5.18 NMTB	-	233	16	-	-
	50			80	110

tipi mandrino disponibili / available spindle types

- 1 DIN6388-ER
ER40
- 2 Albero portafresa
Milling shaft
Ø22-Ø27-Ø32
- 3 Weldon
Whistle-Notch
Ø20-Ø25-Ø32
- 4 DIN69893-HSK
HSK40
- 5 COROMANT
CAPTO®
C4
- 6 ABS
Licenza KOMET®
ABS40

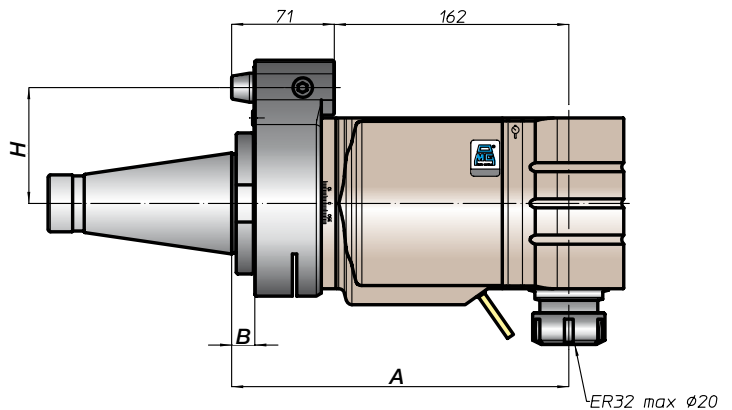
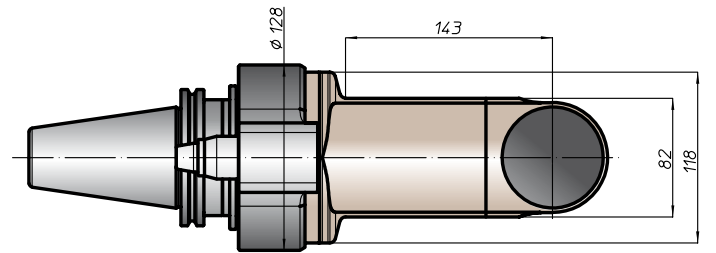
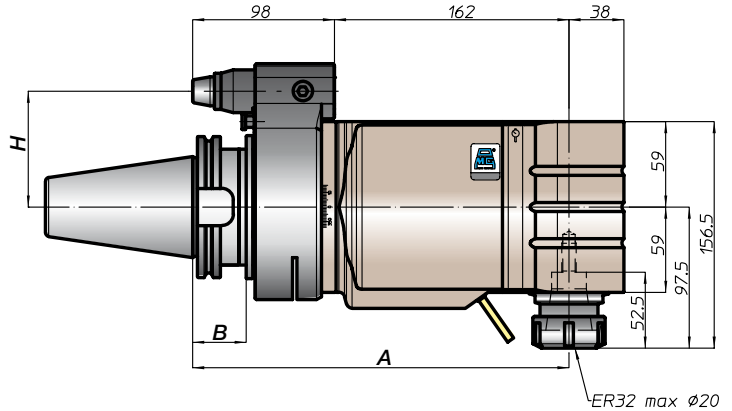
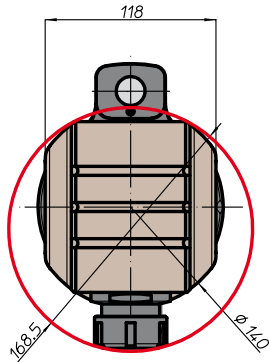

* Option: Dual Contact



BAH
TA.CP
TA
MO
HT
VH
TSI/TSX
T
MT-TC-TC3
Accessori
Accessories
Appendice tecnica
Technical supplement

TA Extended Gallery



TA20.30



caratteristiche/features

peso/weight

prestazioni/performance



14,7 kg

rotazione/rotation

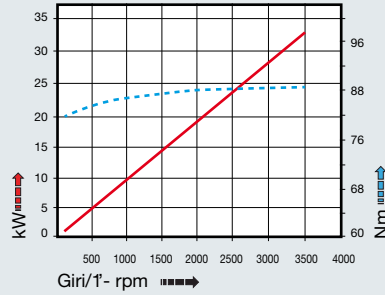
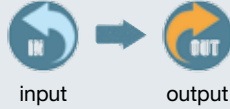

CONO SHANK	size	A	B	H	
				standard	optional
DIN69871 *	-	185	35	-	-
	45			80	110
	50			80	110
ANSIB5.50 *	CAT	-	-	65	-
	50	-	-	80	110
* BT	-	193	45	-	-
	50			80	110
HSK	-	194	46	-	-
	80			80	110
	100			80	110
CAPTO	-	189	-	-	-
	C8			80	110
KM	-	185	-	-	-
	80			80	110
	100			80	110
DIN2080	-	158	16	-	-
	-			80	110
	50			80	110
ANSIB5.18 NMTB	-	158	16	-	-
	50			80	110

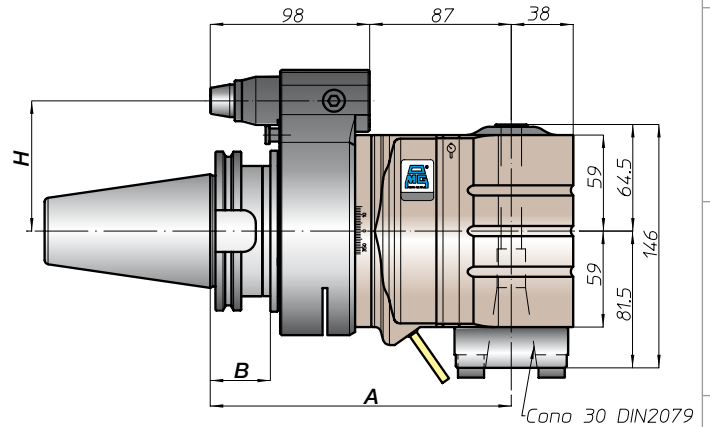
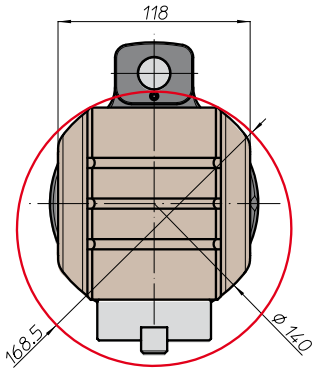

Nota:

- nel mandrino DIN2079 si possono utilizzare coni DIN2080-30, DIN69871-A30, MAS403-BT30

Note:

- on the spindle DIN2079 you can use shank DIN2080-30, DIN69871-A30, MAS403-BT30

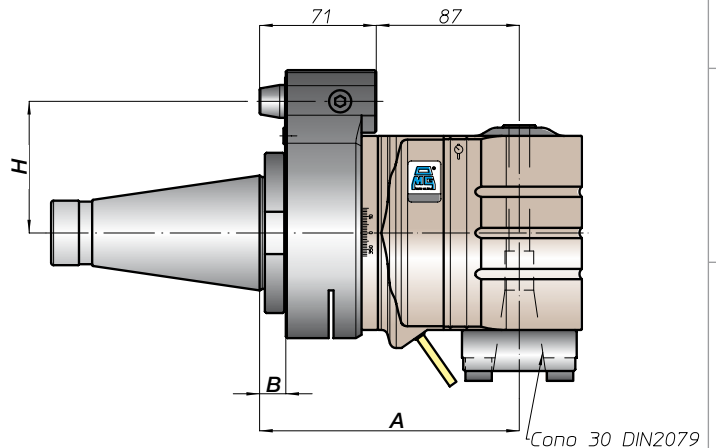
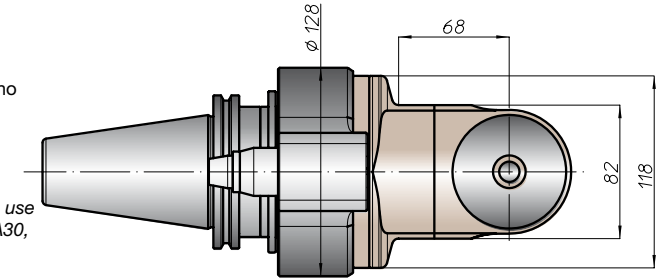

* Option: Dual Contact



BAH
TA.CP
TA
MO
HT
VH
TSI/TSX
T
MT-TC-TC3
Accessori
Accessories
Appendice tecnica
Technical supplement

TA26.P



caratteristiche/features



ø 26



M20



1-1



2500

peso/weight



22 kg

rotazione/rotation



input



output

prestazioni/performance

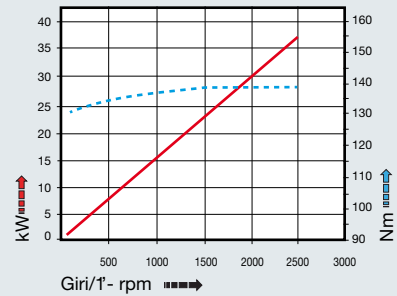

tipi mandrino disponibili / available spindle types

2 Albero portafresa
Milling shaft
Ø16-Ø27-Ø32

3 Weldon
Whistle-Notch
Ø32

4 DIN69893-HSK
HSK63

5 COROMANT
CAPTO®
C4

6 ABS
Licenza KOMET®
ABS50

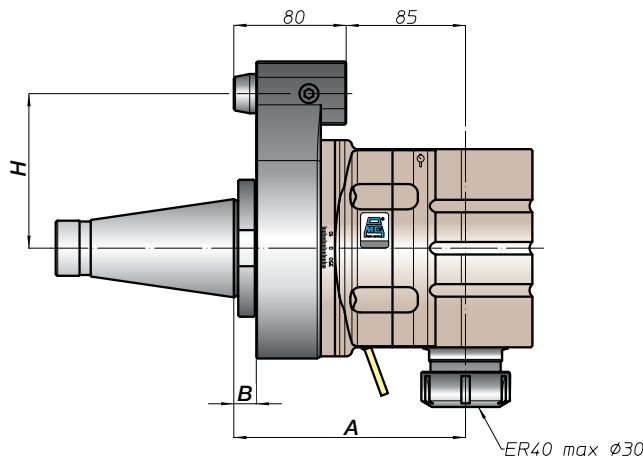
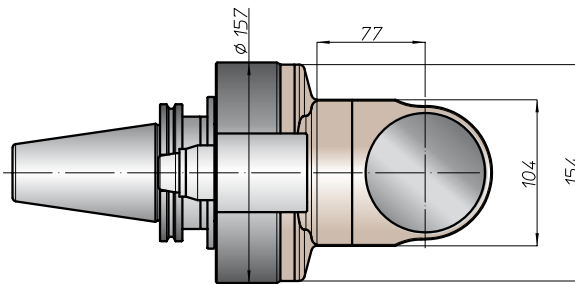
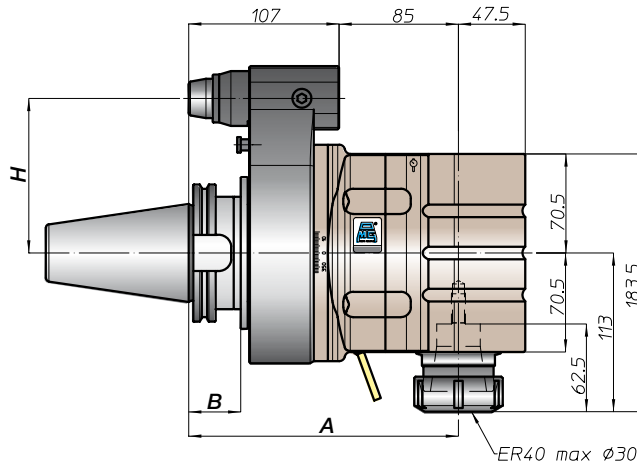
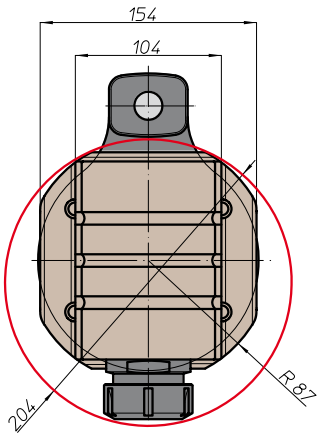

CONO SHANK	size	H			
		A	B	standard	optional
DIN69871 *	-	-	-	-	-
DIN69871 *	45	-	-	110	-
DIN69871 *	50	192	35	110	-
ANSIB5.50 *	-	-	-	-	-
ANSIB5.50 *	50	-	-	110	-
BT *	-	-	-	-	-
BT *	50	200	45	110	-
HSK	-	-	-	-	-
DIN69893	80	201	46	110	-
DIN69893	100	-	-	110	-
CAPTO	-	-	-	-	-
ISO28623	-	196	-	110	-
ISO28623	C8	-	-	110	-
KM	-	-	-	-	-
KM	-	192	-	110	-
KM	100	-	-	110	-
DIN2080	-	-	-	-	-
DIN2080	-	165	16	110	-
DIN2080	50	-	-	110	-
NMTB	-	-	-	-	-
ANSIB5.18	50	165	16	110	-

* Option: Dual Contact



TA26.40



caratteristiche/features

peso/weight

prestazioni/performance



22 kg

rotazione/rotation

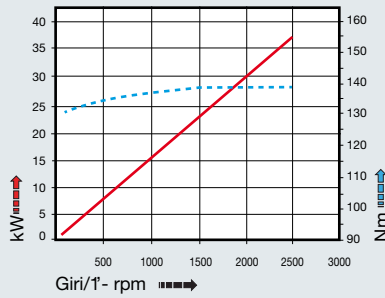

CONO SHANK	size	A	B	H	
				standard	optional
* DIN69871 *	-	192	35	-	-
	45			110	-
	50			110	-
* ANSIB5.50 *	CAT	-	-	-	-
	50	-	-	110	-
* BT	-	-	-	-	-
	50	200	45	110	-
HSK	-	-	-	-	-
	DIN69893	80	201	46	110
	100	-	-	-	-
CAPTO	-	-	-	-	-
	ISO26623	-	196	-	110
KM	-	-	-	-	-
	-	192	-	-	-
	100	-	-	110	-
DIN2080	-	-	-	-	-
	-	165	16	110	-
50	-	-	-	-	-
	-	165	16	110	-
NMTB	-	-	-	-	-
	ANSIB5.18	50	165	16	110

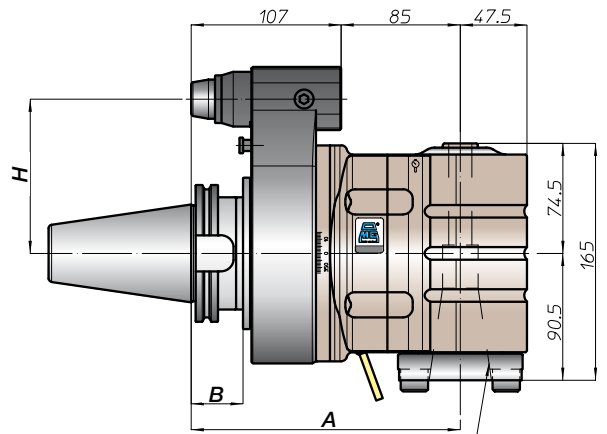
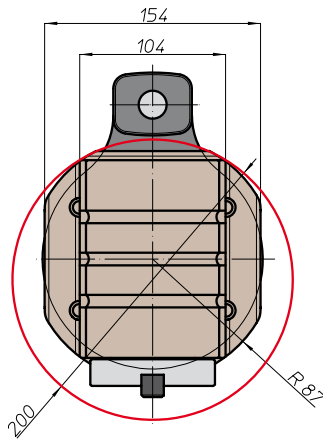

Cono 40 DIN2079

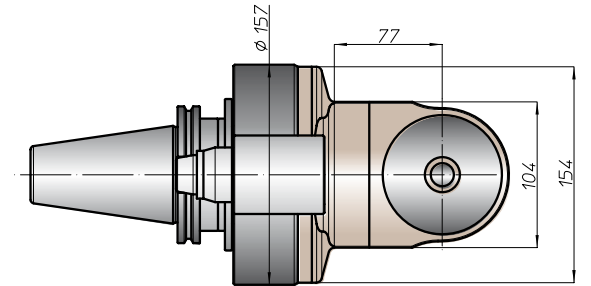

Nota:

- nel mandrino DIN2079 si possono utilizzare coni DIN2080-40, DIN69871-A40, MAS403-BT40

Note:

- on the spindle DIN2079 you can use shank DIN2080-40, DIN69871-A40, MAS403-BT40

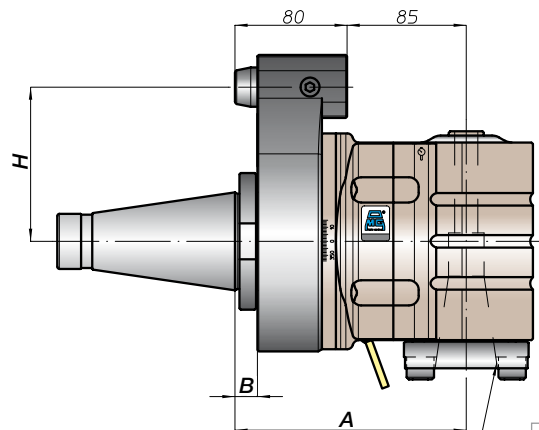

Cono 40 DIN2079

* Option: Dual Contact

testa ad angolo - angle head

TA07.2P



caratteristiche/features



peso/weight



rotazione/rotation



prestazioni/performance

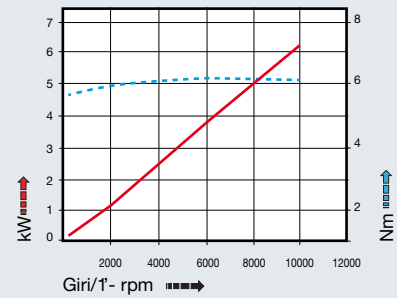

tipi mandrino disponibili / available spindle types

3 Weldon Whistle-Notch
Ø10

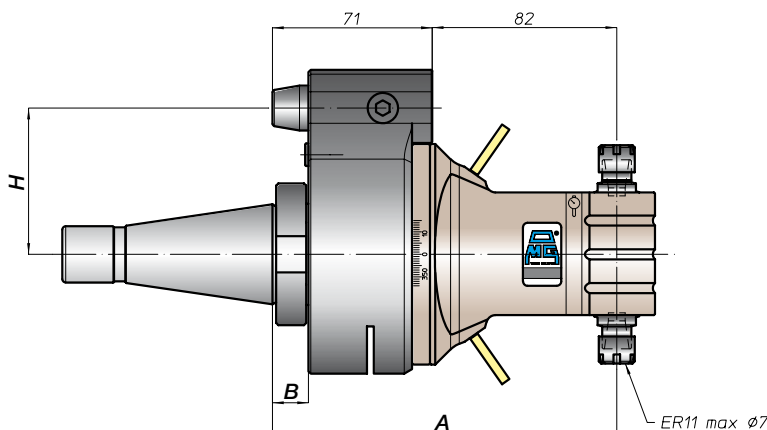
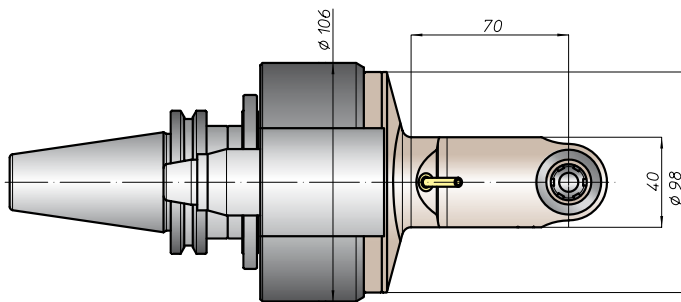
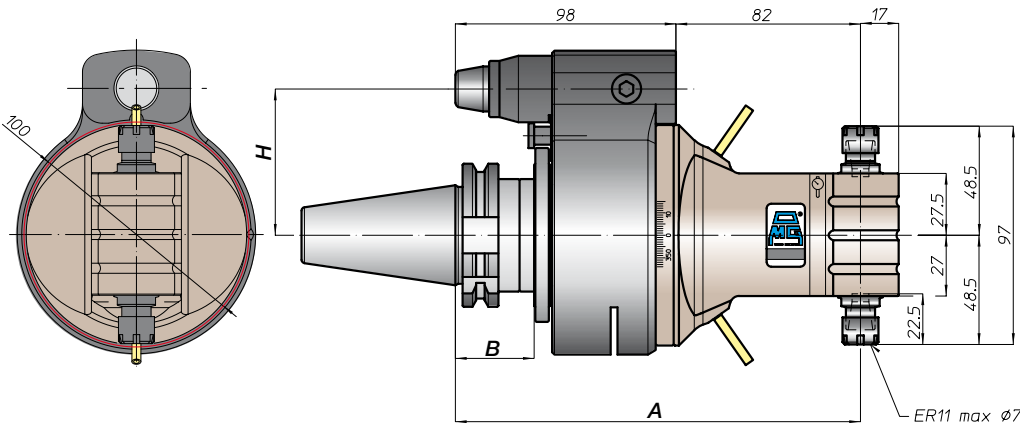

CONO SHANK	size	H		
		A	B	standard / optional
* DING9871	30			65 -
	40			65 -
	45			80 110
	50	180	35	80 110
* ANSIB5.50 CAT	40			65 -
	50			80 110
* BT	40			65
	50	188	45	80 110
DING9893 HSK	63		44	65
	80	189		80 110
	100		46	80 110
ISO28623 CAPTO	C5			65
	C6	184	39	80 110
	C8			80 110
KM	63			65
	80	180		80 110
	100			80 110
DIN2080	40	150	13	65 -
	50	153	16	80 110
ANSIB5.18 NMTB	40	150	13	65 -
	50	153	16	80 110

* Option: Dual Contact

BAH

TA-CP

TA

MO

HT

VH

TSI/TSX

T

MT-TC-TC3

Accessori
Accessories

Appendice tecnica
Technical supplement



TA10.2P



caratteristiche/features

peso/weight

prestazioni/performance

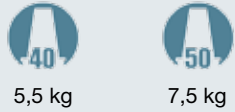

rotazione/rotation

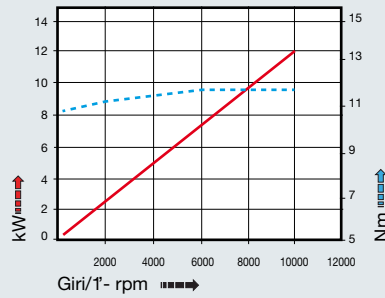

CONO SHANK	size	A	B	H	
				standard	optional
DING9871 *	30	180	35	65	-
	40			80	110
	45			80	110
	50			80	110
ANSIB5.50 *	CAT			65	-
				80	110
* BT	40			65	
	50	188	45	80	110
HSK	63	189	44	65	
	80			80	110
	100			80	110
CAPTO	C5	184	39	65	
	C6			80	110
	C8			80	110
KM	63	180		65	
	80			80	110
	100			80	110
DIN2080	-	150	13	65	-
	40	153	16	80	110
	50			80	110
ANSIB5.18 NMTB	40	150	13	65	-
	50	153	16	80	110

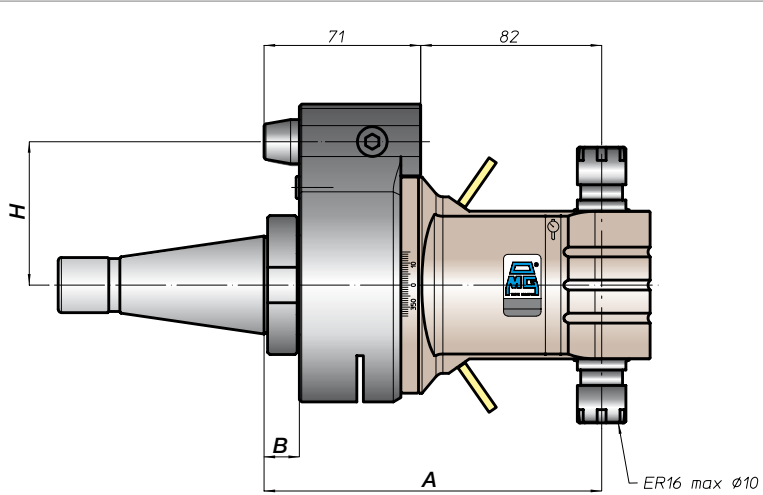
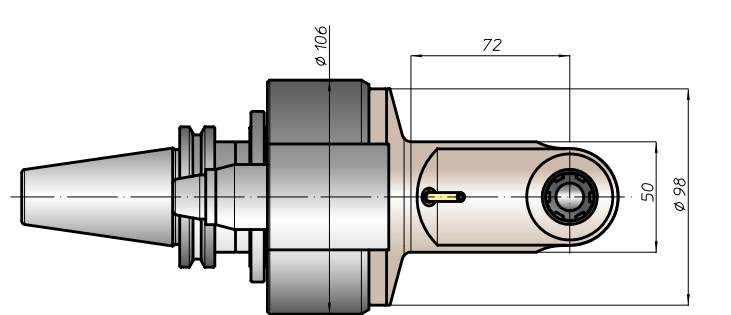
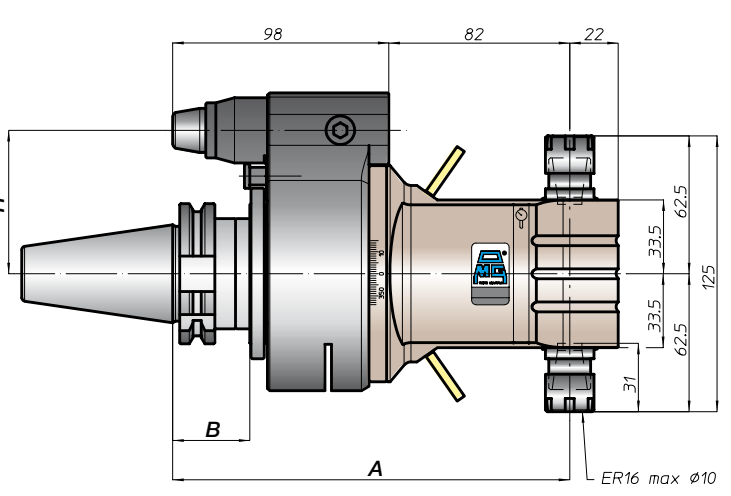
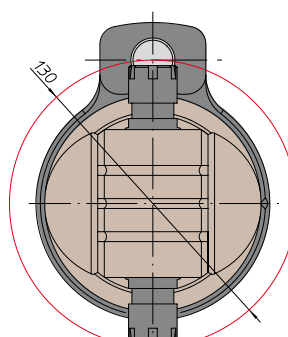

* Option: Dual Contact



BAH
TA.CP
TA
MO
HT
VH
TSI/TSX
T
MT-TC-TC3
Accessori
Accessories
Appendice tecnica
Technical supplement

TA13.2P



caratteristiche/features



ø 13



M10



1-1



8000

peso/weight



6,5 kg



9 kg

rotazione/rotation



input



output

prestazioni/performance

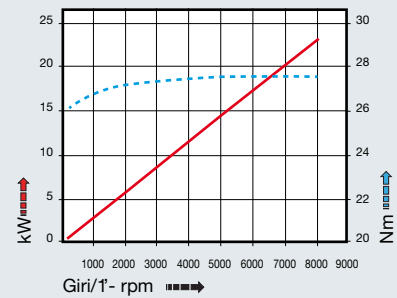

tipi mandrino disponibili / available spindle types

1 DIN6388-ER
ER25

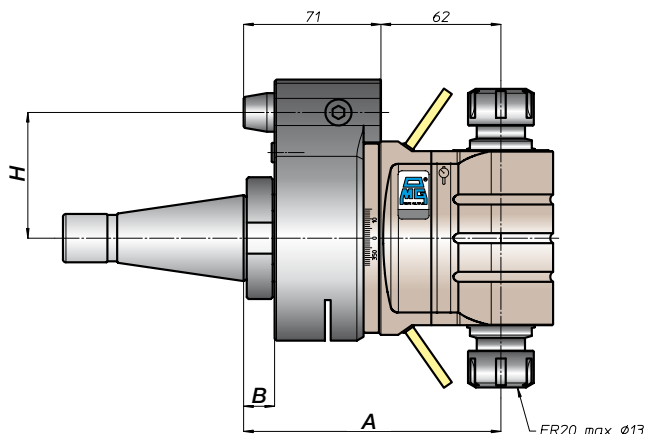
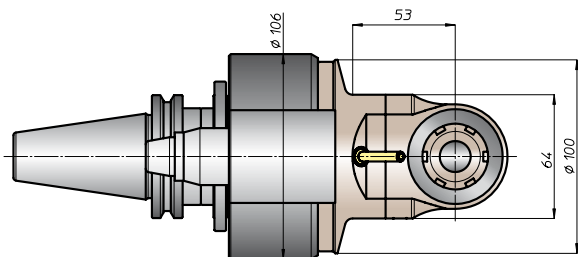
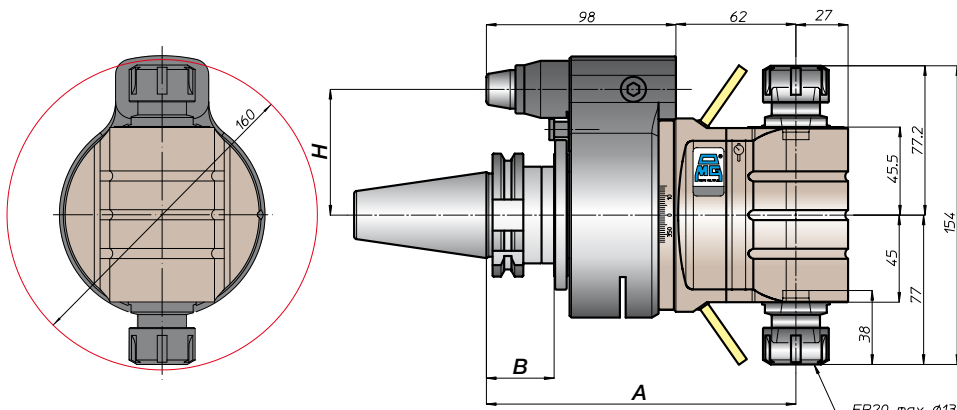

CONO SHANK	size	H			
		A	B	standard	optional
DIN69871 *	-			65	-
	40	160	35	80	110
	45				
50					
ANSI B5.50 *	CAT			65	-
	40			80	110
	50				
*	BT			65	
	40			80	110
DIN69893	HSK			65	
	63		44	80	110
	80	169	46		
ISO 28623	CAPTO			65	
	C5			80	110
	C6	164	39		
KM	C8			80	110
	63			65	
	80	160		80	110
DIN2080	100				
	-	130	13	65	-
	40				
ANSI B5.18	-	133	16	80	110
	50				
NMTB	40	130	13	65	-
	50	133	16	80	110

* Option: Dual Contact



TA16.2P



caratteristiche/features

peso/weight

prestazioni/performance

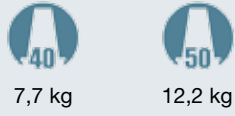

rotazione/rotation

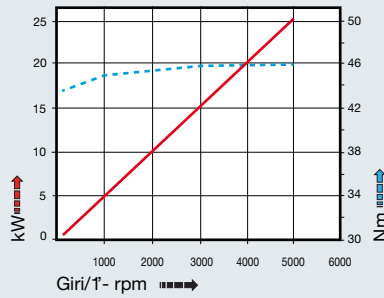
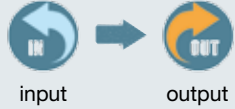

CONO SHANK	size	A	B	H	
				standard	optional
DING9871 *	-	172	35	65	-
	40	172		65	-
	45	177		80	110
ANSIB5.50 * CAT	40	172	65	-	
	50	177	80	110	
* BT	40	172	65	-	
	50	185	45	80	110
HSK	63	181	44	65	-
	80	186	46	80	110
	100	186	46	80	110
CAPTO	C5	176	39	65	-
	C6	176		65	-
	C8	181		80	110
KM	63	172	35	65	-
	80	172		65	-
	100	177		80	110
DIN2080	-	147	13	65	-
	40	147	13	65	-
	50	150	16	80	110
NMTB	40	142	13	65	-
	50	150	16	80	110

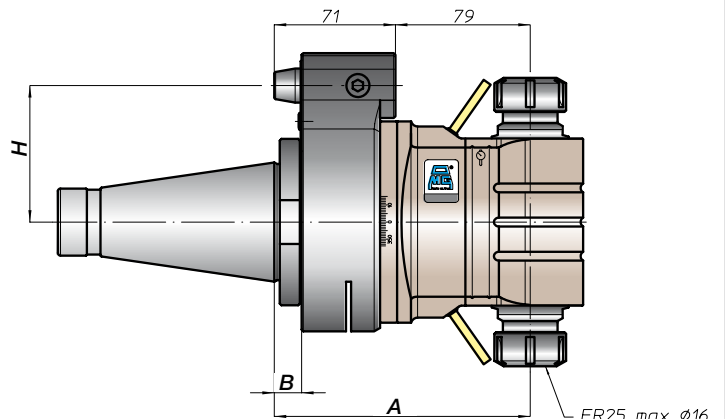
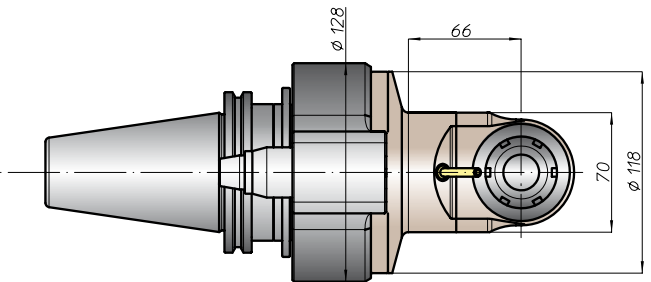
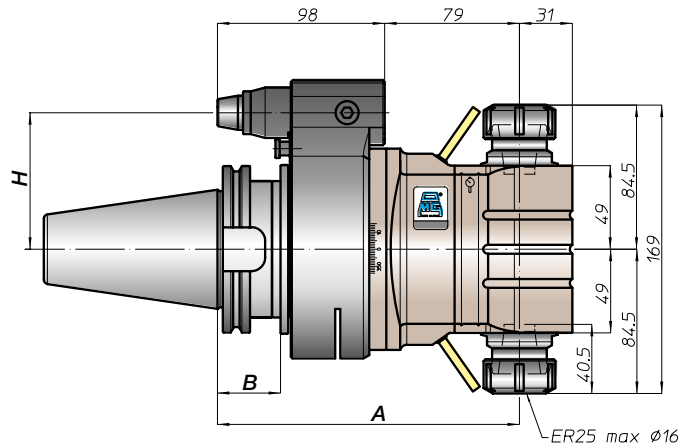
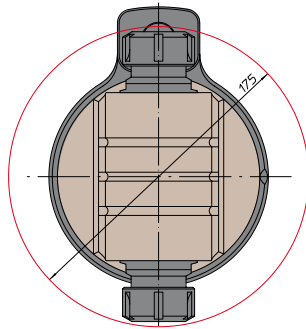

* Option: Dual Contact



BAH
TA.CP
TA
MO
HT
VH
TSI/TSX
T
MT-T-C3
Accessori
Accessories
Appendice tecnica
Technical supplement

TA20.2P



caratteristiche/features



ø 20



M14



1-1



3500

peso/weight



15 kg

rotazione/rotation



input



output

prestazioni/performance

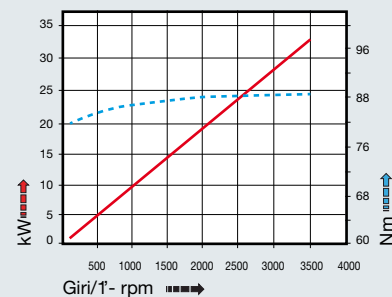

tipi mandrino disponibili / available spindle types

- 2** Albero portafresa
Milling shaft
Ø32
- 3** Weldon
Whistle-Notch
Ø20

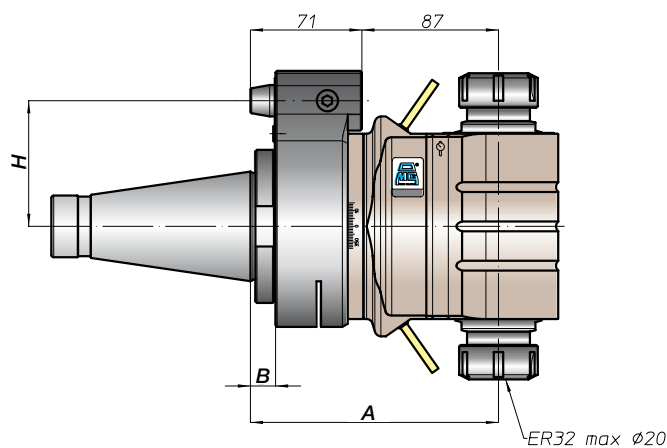
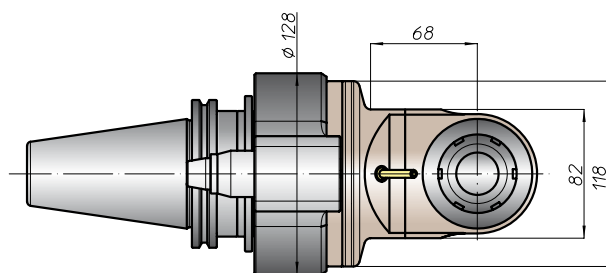
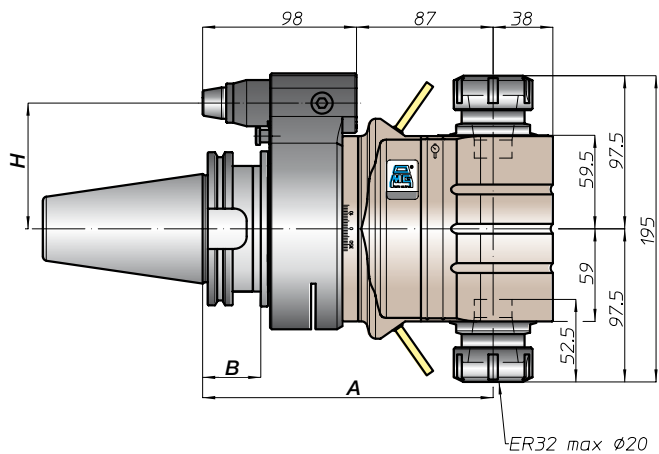
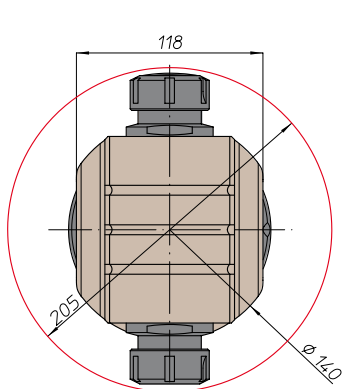

CONO SHANK	size	H			
		A	B	standard	optional
DIN69871 *	-	-	-	-	-
	45	-	-	80	110
	50	185	35	80	110
ANSI B5.50 *	CAT	-	-	-	-
	50	-	-	80	110
	BT	-	-	-	-
	50	193	45	80	110
HSK	-	-	-	-	-
DIN69893	80	194	-	80	110
	100	-	46	80	110
CAPTO	-	-	-	-	-
ISO28623	-	189	-	80	110
	C8	-	-	80	110
KM	-	-	-	-	-
	80	185	-	80	110
	100	-	-	80	110
DIN2080	-	-	-	-	-
	-	-	-	-	-
	50	158	16	80	110
NMTB	-	-	-	-	-
ANSI B5.18	50	158	16	80	110

* Option: Dual Contact

BAH
TA-CP
TA
MO
HT
VH
TSI/TSX
T
MT-TC-TC3
Accessori
Accessories
Appendice tecnica
Technical supplement



TA26.2P

caratteristiche/features

peso/weight

prestazioni/performance



22,5 kg

rotazione/rotation

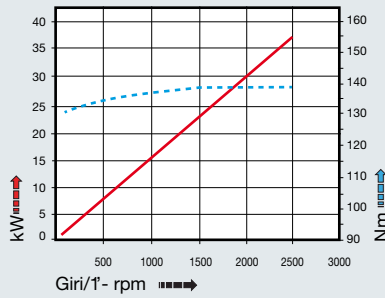

CONO SHANK	size	A	B	H	
				standard	optional
DING9871 *	-	-	-	-	-
	45	-	-	-	-
ANSIB5.50 *	50	192	35	110	-
	50	-	-	-	-
BT *	50	200	45	110	-
	50	-	-	-	-
HSK	80	-	-	-	-
	100	201	46	110	-
CAPTO	-	196	-	-	-
	C8	-	-	110	-
KM	-	192	-	-	-
	100	-	-	110	-
DIN2080	-	165	16	110	-
	50	-	-	-	-
ANSIB5.18 NMTB	-	165	16	110	-
	50	-	-	-	-

tipi mandrino disponibili / available spindle types

- 2** Albero portafresa Milling shaft
- 3** Weldon Whistle-Notch
- 6** ABS Licenza KOMET®

Ø16-Ø27-Ø32

Ø32

ABS50

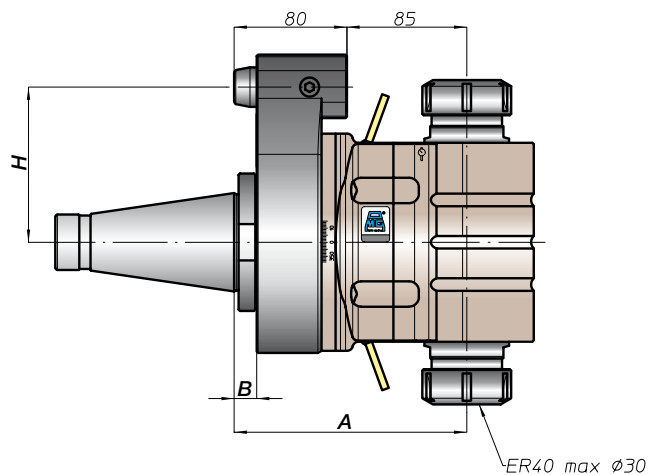
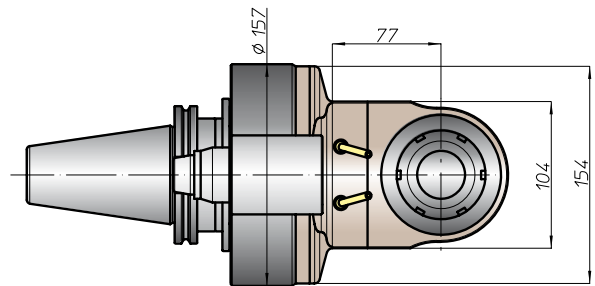
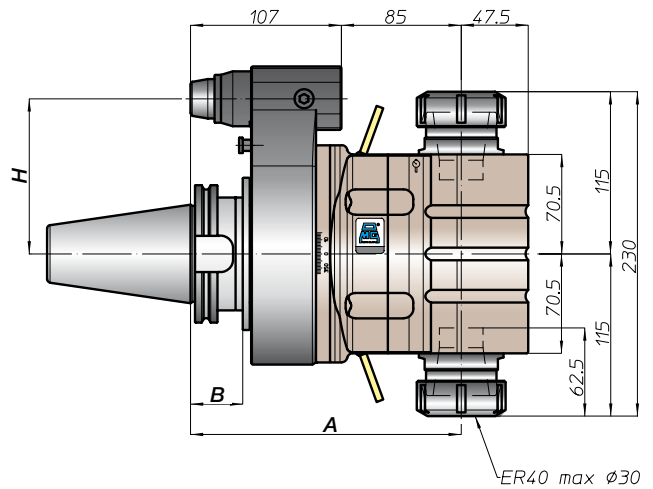
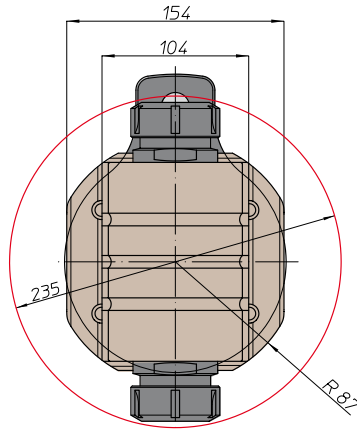

* Option: Dual Contact



BAH
TA.CP
TA
MO
HT
VH
TSI/TSX
T
MT-TC-TC3
Accessori
Accessories
Appendice tecnica
Technical supplement

testa ad angolo - angle head

TA07.PD



caratteristiche/features



ø 7 M6 1-1



10000 10 bar

peso/weight



40

5 kg



50

7 kg

rotazione/rotation



input



output

prestazioni/performance

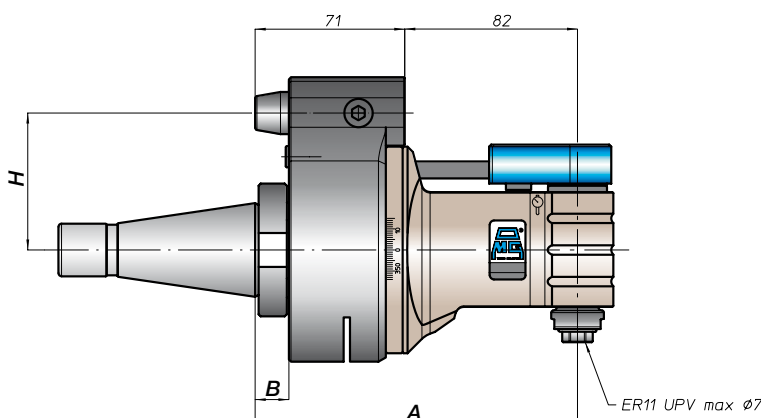
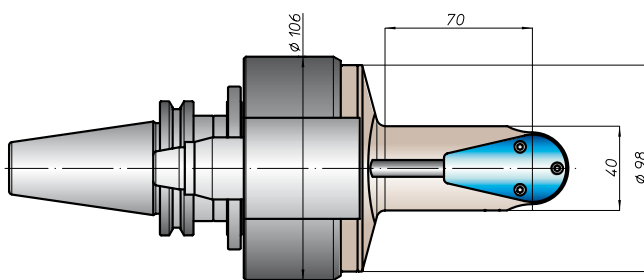
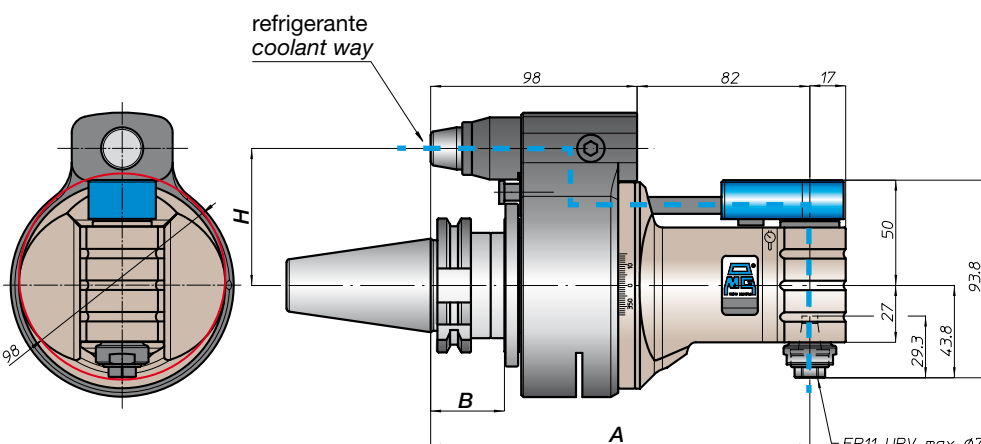
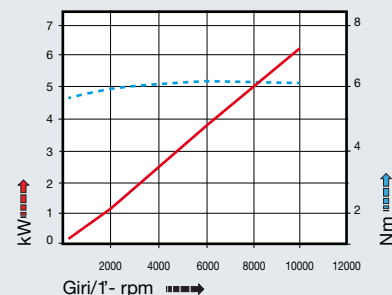

CONO SHANK	size	H			
		A	B	standard	optional
DIN9871 *	30			65	-
	40			80	110
	45	150	35	80	110
ANSIB5.50 *	40			65	-
	50			80	110
* BT	40			65	
	50	158	45	80	110
HSK	63		44	65	
	80	159		80	110
	100		46	80	110
ISO28623	C5			65	
	C6	154	39		
	C8			80	110
KM	63			65	
	80	150		80	110
	100			80	110
DIN2080	40	120	13	65	-
	50	123	16	80	110
ANSIB5.18	40	120	13	65	-
	50	123	16	80	110

* Option: Dual Contact

BAH

TA-CP

TA

MO

HT

VH

TSI/TSX

T

MT-TC-TC3

Accessori
Accessories

Appendice tecnica
Technical supplement



TA07.PDL



caratteristiche/features

peso/weight

prestazioni/performance



rotazione/rotation

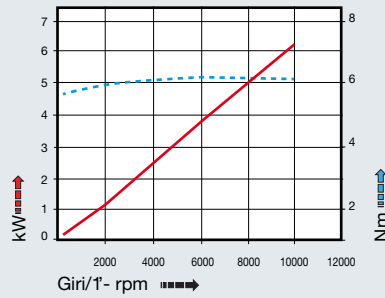

CONO SHANK	size	A	B	H	
				standard	optional
DING9871 *	40	250	35	65	-
	45			80	110
	50			80	110
ANSIB5.50 *	CAT	258	45	65	-
	BT			80	110
DING9893	HSK	259	44	65	-
	80			80	110
	100			46	80
ISO26623	C5	254	39	65	-
	C6			80	110
	C8			80	110
KM	63	250	13	65	-
	80			80	110
	100			80	110
DIN2080	-	223	16	65	-
	40			80	110
	50			80	110
ANSIB5.18	NMTB	223	16	65	-
	40			80	110

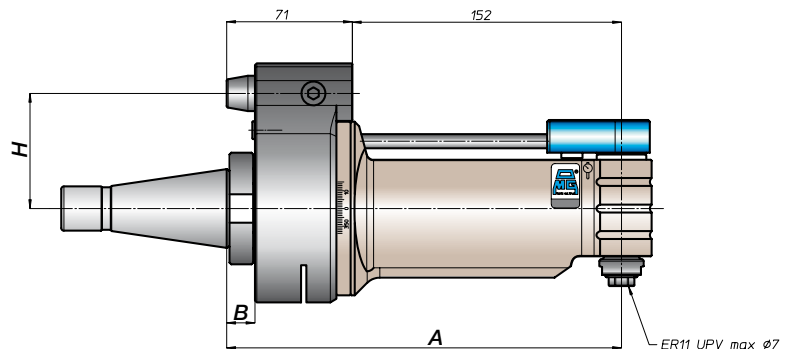
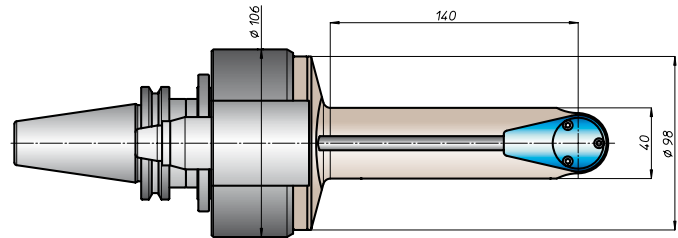
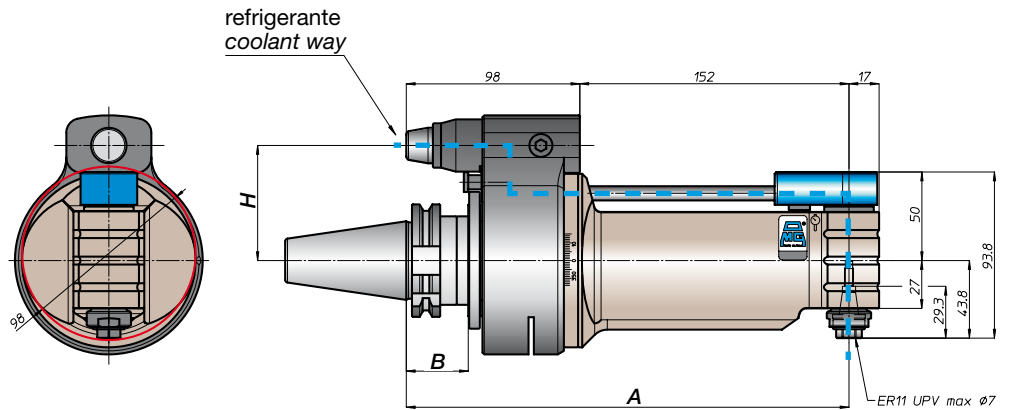

* Option: Dual Contact



BAH
TA.CP
TA
MO
HT
VH
TSI/TSX
T
MT-T-C3
Accessori
Accessories
Appendice tecnica
Technical supplement

testa ad angolo - angle head

TA10.PD



caratteristiche/features



ø 10 M8 1-1



10000 10 bar

peso/weight



5,8 kg



8 kg

rotazione/rotation



input



output

prestazioni/performance

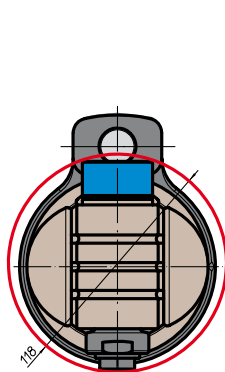
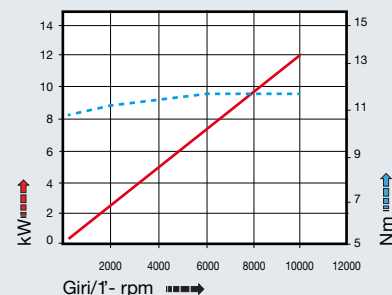

refrigerante
coolant way

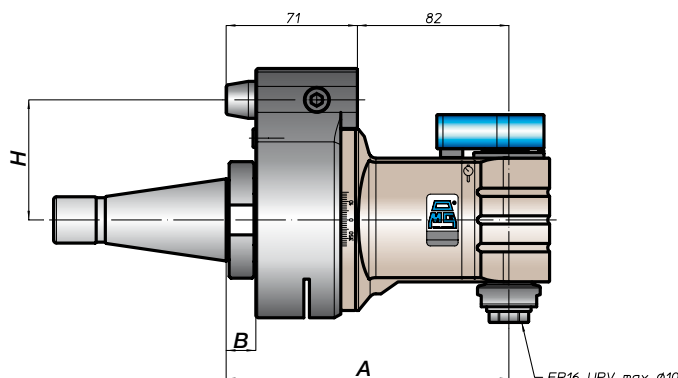
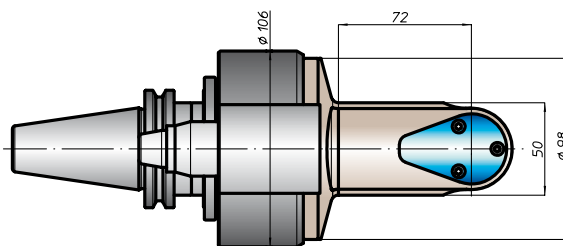
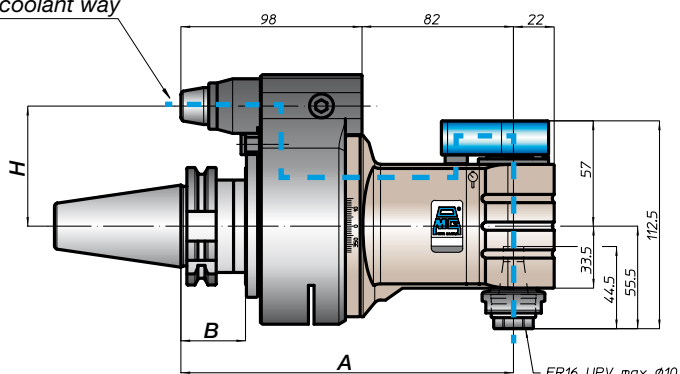

CONO SHANK	size	H			
		A	B	standard	optional
* DING9871	30	180	35	65	-
	40			80	110
	45			80	110
* ANSIB5.50 CAT	40	180	35	65	-
	50			80	110
* BT	40	188	45	65	-
	50			80	110
DING9893 HSK	63	189	46	44	65
	80			80	110
	100			80	110
ISO28623 CAPTO	C5	184	39	65	-
	C6			80	110
	C8			80	110
KM	63	180	13	65	-
	80			80	110
	100			80	110
DIN2080	40	153	16	65	-
	50			80	110
ANSIB5.18 NMTB	40	150	13	65	-
	50			80	110

* Option: Dual Contact

BAH

TA-CP

TA

MO

HT

VH

TSI/TSX

T

MT-TC-TC3

Accessori
Accessories

Appendice tecnica
Technical supplement



TA10.PDL

caratteristiche/features

peso/weight

prestazioni/performance



rotazione/rotation

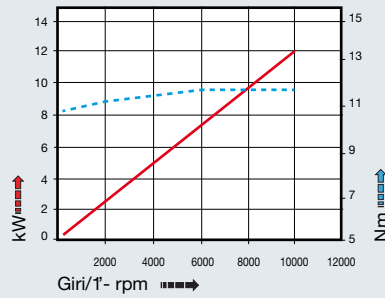

CONO SHANK	size	A	B	H	
				standard	optional
DING9871 *	40	250	35	65	-
	45			80	110
	50			80	110
ANSIB5.50 *	CAT	258	45	65	-
	BT			80	110
DING9893	HSK	284	39	65	-
	80			80	110
	100			80	110
ISO26623	C5	220	13	65	-
	C6			80	110
	C8			80	110
KM	63	250	16	65	-
	80			80	110
	100			80	110
DIN2080	-	223	16	65	-
	40			80	110
	50			80	110
ANSIB5.18	NMTB	223	16	65	-
	50			80	110

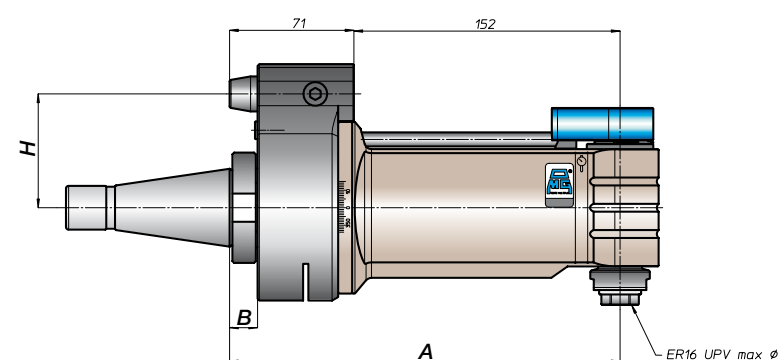
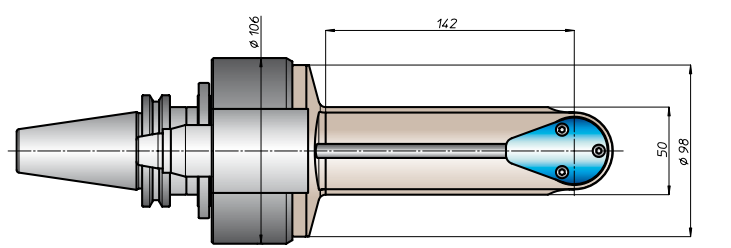
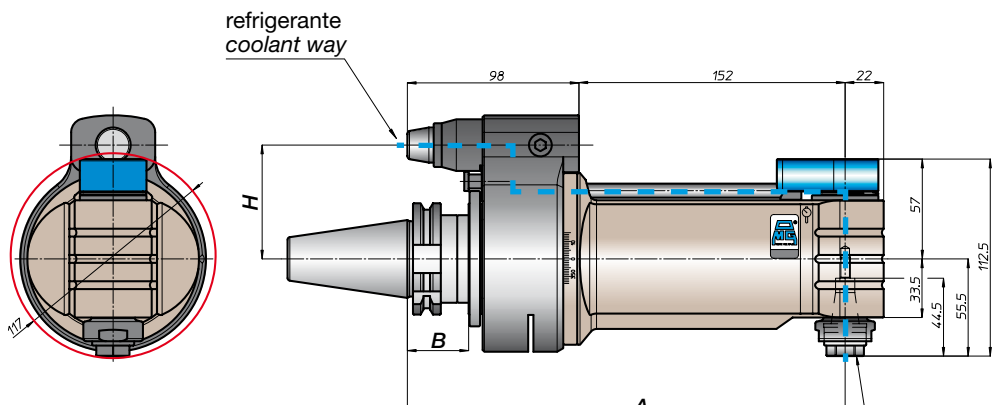

* Option: Dual Contact



BAH
TA.CP
TA
MO
HT
VH
TSI/TSX
T
MT-T-C3
Accessori
Accessories
Appendice tecnica
Technical supplement

testa ad angolo - angle head

TA13.PD



caratteristiche/features



peso/weight



rotazione/rotation



prestazioni/performance

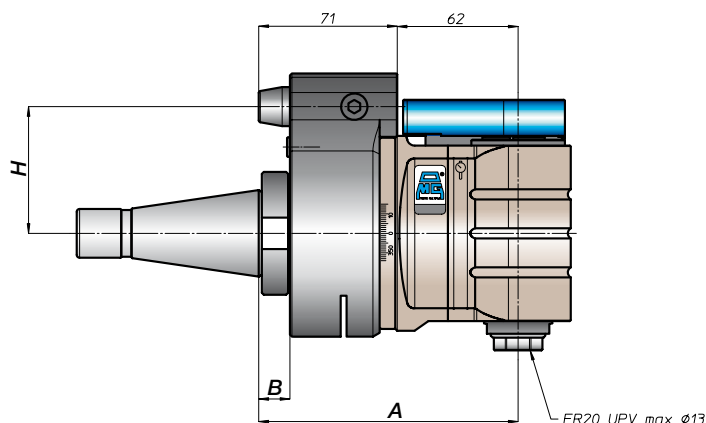
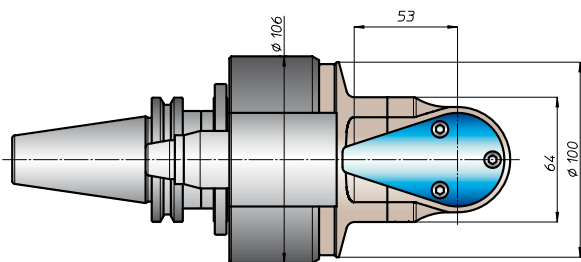
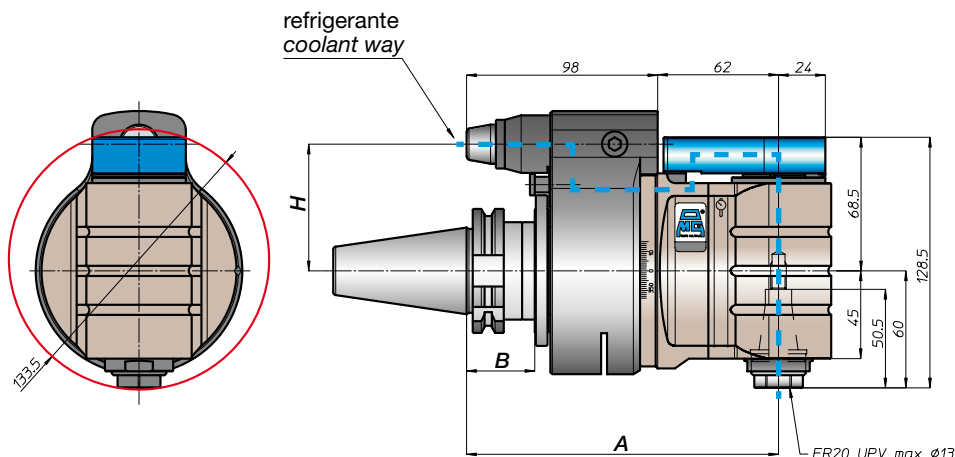
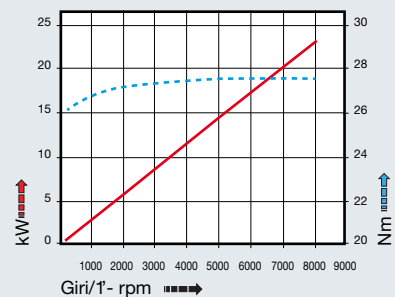

CONO SHANK	size	H			
		A	B	standard	optional
DIN9871 *	-			65	-
	40			65	-
	45			80	110
ANSI B5.50 *	50	160	35	80	110
	CAT			65	-
	50			80	110
BT *	40			65	
	50	168	45	80	110
HSK	63		44	65	
	80	169		80	110
	100		46	80	110
ISO 28623	C5			65	
	C6	164	39		
	C8			80	110
KM	63			65	
	80	160		80	110
	100			80	110
DIN2080	-	130	13	65	-
	40			65	-
	50	133	16	80	110
ANSI B5.18	NMTB			65	-
	40	130	13	65	-
	50	133	16	80	110

* Option: Dual Contact

BAH

TA-CP

TA

MO

HT

VH

TSI/TSX

T

MT-TC-TC3

Accessori
Accessories

Appendice tecnica
Technical supplement



TA16.PD



caratteristiche/features

peso/weight

prestazioni/performances



rotazione/rotation

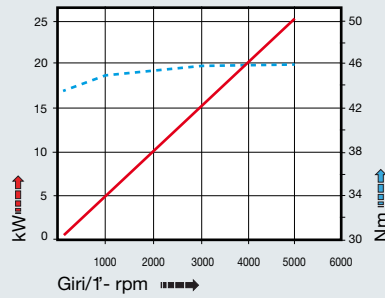

CONO SHANK	size	A	B	H	
				standard	optional
DING9871 *	-	172	35	65	-
	40	172		65	-
	45	177		80	110
ANSIB5.50 *	40	172	65	-	
	50	177	80	110	
* BT	40	172	65		
	50	185	45	80	110
HSK	63	181	44	65	
	80	186	46	80	110
	100			80	110
CAPTO	C5	176	39	65	
	C6	181		80	110
	C8	181		80	110
KM	63	172	65		
	80	177	80	110	
	100		80	110	
DIN2080	-	147	13	65	-
	40	150	16	80	110
	50			80	110
ANSIB5.18	40	142	13	65	-
	50	150	16	80	110

tipi mandrino disponibili / available spindle types

1 DIN6388-ER
ER32

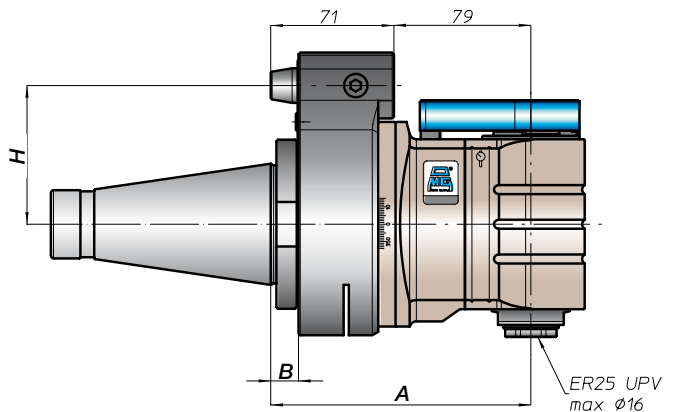
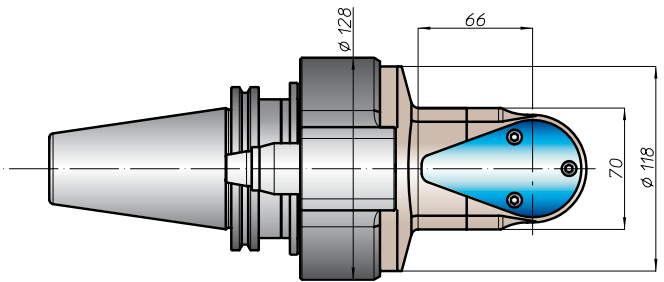
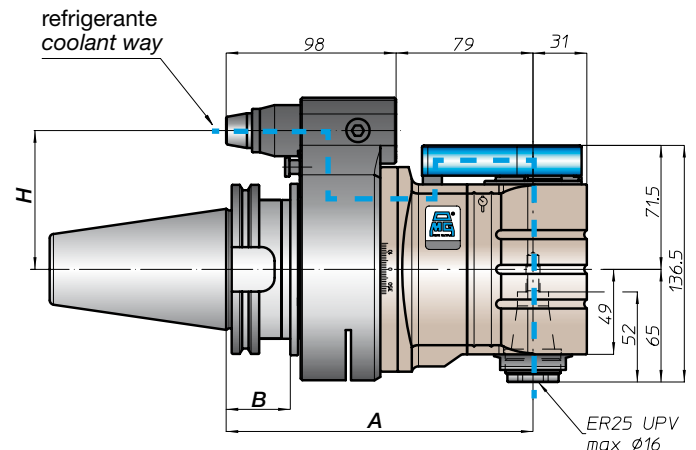
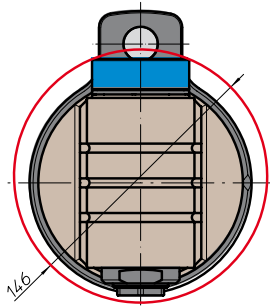

* Option: Dual Contact



TA20.PD



caratteristiche/features



peso/weight



14,5 kg

rotazione/rotation



prestazioni/performance

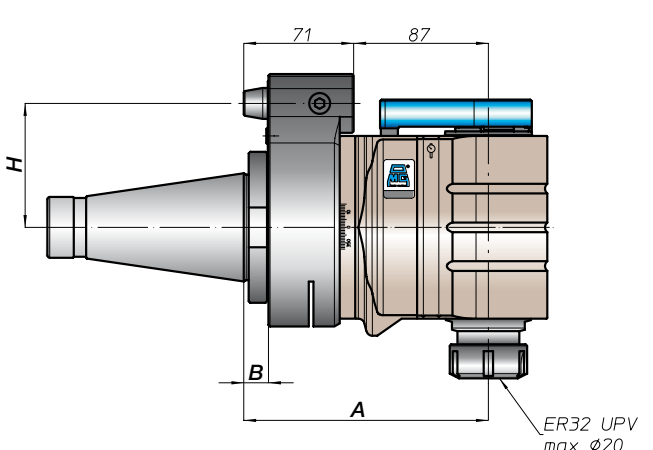
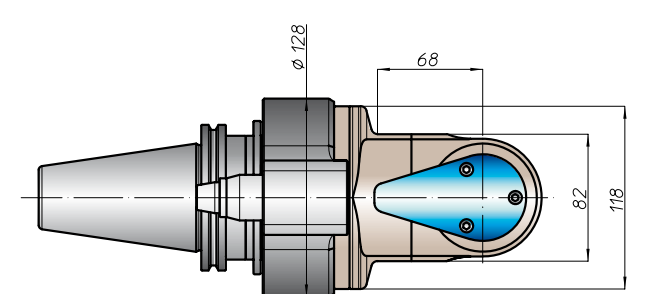
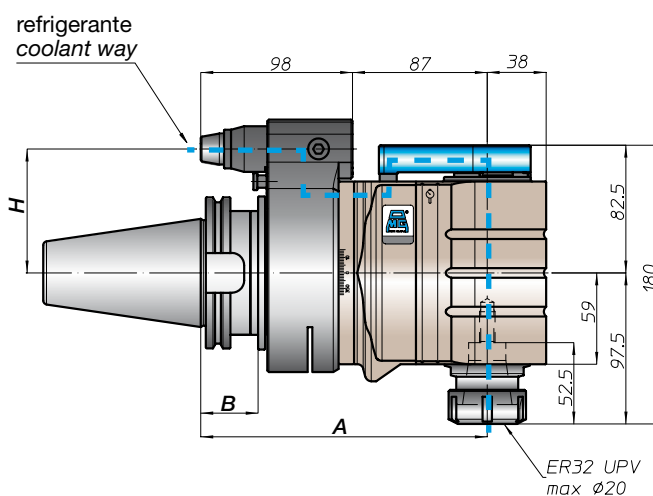
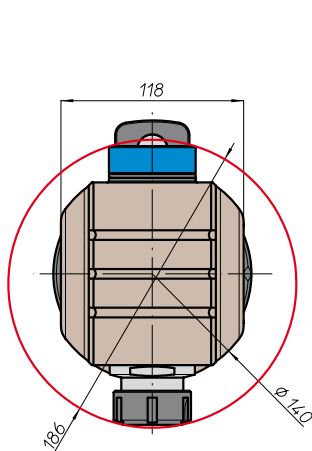
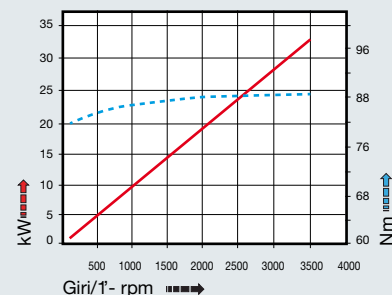

CONO SHANK	size	H			
		A	B	standard	optional
DIN9871 *	-	-	-	-	-
DIN9871 *	45	-	-	80	110
	50	185	35	80	110
ANSIB5.50 *	-	-	-	-	-
ANSIB5.50 *	50	-	-	80	110
	50	193	45	80	110
BT *	-	-	-	-	-
BT *	50	193	45	80	110
	50	193	45	80	110
HSK	-	-	-	-	-
DIN9893	80	194	-	80	110
	100	-	46	80	110
CAPTO	-	-	-	-	-
ISO28623	-	189	-	80	110
	C8	-	-	80	110
KM	-	-	-	-	-
KM	80	185	-	80	110
	100	-	-	80	110
DIN2080	-	-	-	-	-
DIN2080	-	-	-	-	-
	50	158	16	80	110
NMTB	-	-	-	-	-
ANSIB5.18	-	-	-	-	-
	50	158	16	80	110

* Option: Dual Contact

BAH
TA-CP
TA
MO
HT
VH
TSI/TSX
T
MT-TC-TC3
Accessori
Accessories
Appendice tecnica
Technical supplement



TA26.PD

caratteristiche/features

peso/weight

prestazioni/performance



22 kg

rotazione/rotation



input



output

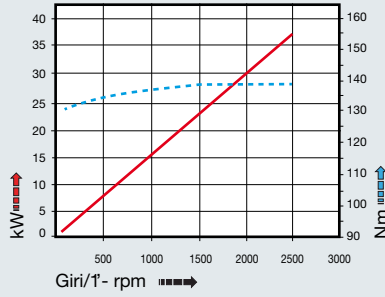

CONO SHANK	size	A	B	H	
				standard	optional
DIN69871 *	-	192	35	-	-
	45			110	-
ANSIB5.50 *	-	192	35	-	-
	50			110	-
BT *	-	200	45	110	-
	50			110	-
HSK	-	201	46	110	-
	80			110	-
CAPTO	-	196	-	110	-
	-			110	-
KM	-	192	-	110	-
	-			110	-
DIN2080	-	165	16	110	-
	50			110	-
NMTB	-	165	16	110	-
	50			110	-

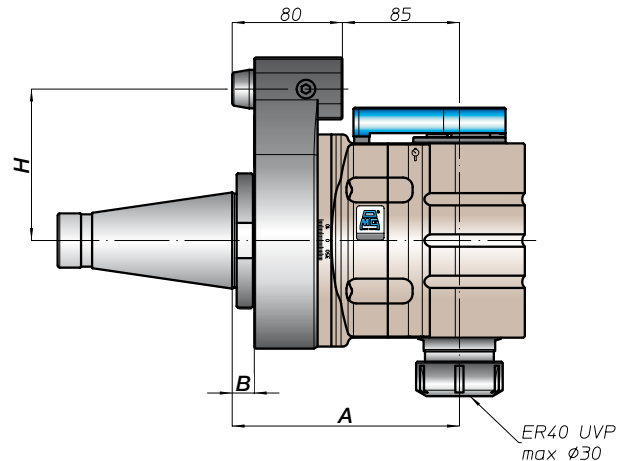
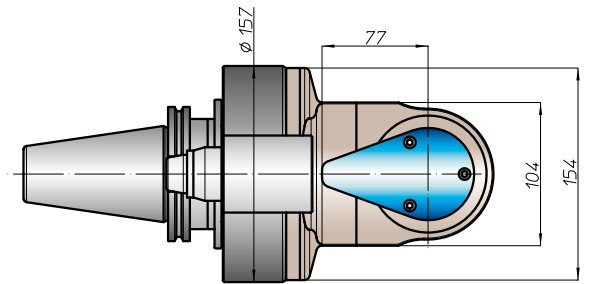
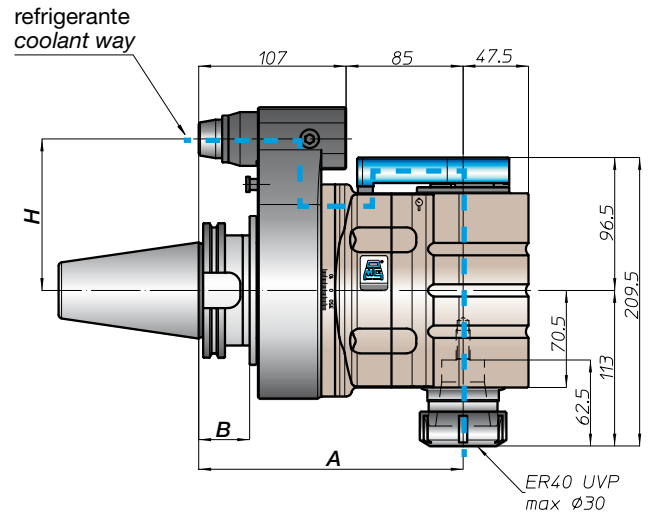
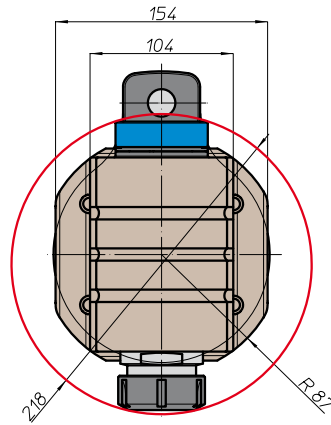

* Option: Dual Contact



BAH
TA.CP
TA
MO
HT
VH
TSI/TSX
T
MT-T-C3
Accessori
Accessories
Appendice tecnica
Technical supplement

BAH
TA-CP
TA
MO
HT
VH
TSI/TSX
T
MT-TC-TC3
Accessori
Accessories
Appendice tecnica
Technical supplement
3-46



testa ad angolo - angle head

TA26.40.D

caratteristiche/features





 ø 26 M20 1-1

 2500 40 bar

peso/weight

 22 kg

rotazione/rotation

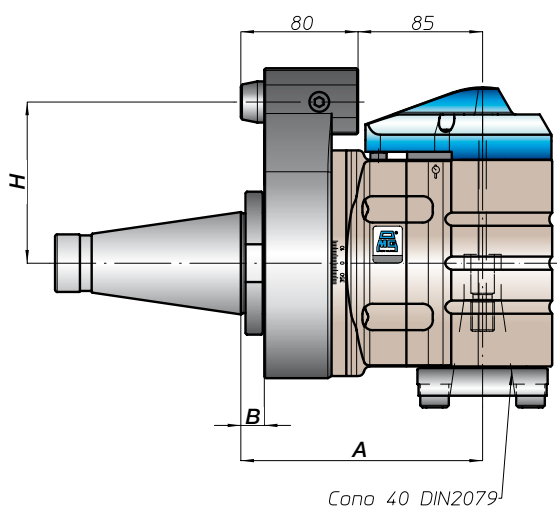
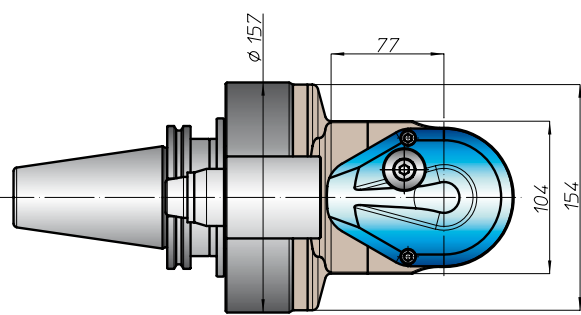
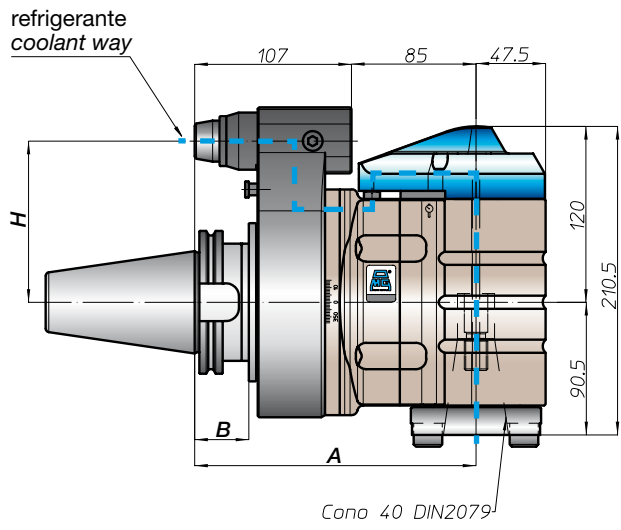
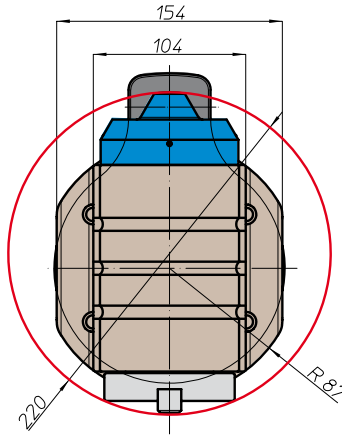
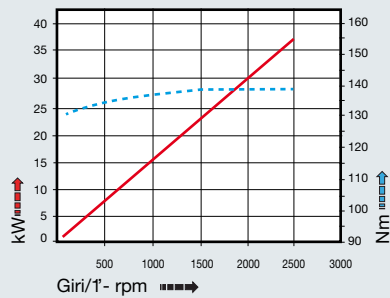

 input output

prestazioni/performance



CONO SHANK	size	H			
		A	B	standard	optional
DIN69871 *	-	-	-	-	-
	45	-	-	110	-
	50	192	35	-	-
ANSIB5.50 *	-	-	-	-	-
	50	-	-	110	-
* BT	-	-	-	-	-
	50	200	45	110	-
HSK	-	-	-	-	-
DIN69893	80	-	-	110	-
	100	201	46	-	-
CAPTO	-	-	-	-	-
ISO26623	-	196	-	110	-
	C8	-	-	-	-
KM	-	-	-	-	-
	-	192	-	110	-
	100	-	-	-	-
DIN2080	-	-	-	-	-
	-	165	16	110	-
	50	-	-	-	-
NMTB	-	-	-	-	-
ANSIB5.18	50	165	16	110	-

* Option: Dual Contact



BAH

TA.CP

TA

MO

HT

VH

TSI/TSX

T

MT-TC-TC3

Accessori
Accessories

Appendice tecnica
Technical supplement



testa ad angolo - angle head

TAO10.P



caratteristiche/features



ø 10



M8



1-1



6000

peso/weight



6,2 kg



8,7 kg

rotazione/rotation



input



output

prestazioni/performance

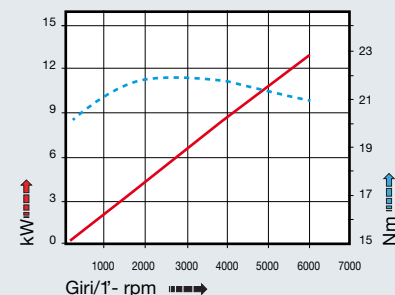

tipi mandrino disponibili / available spindle types

- 2** Albero portafresa
Milling shaft
Ø16
- 4** DIN69893-HSK
HSK25

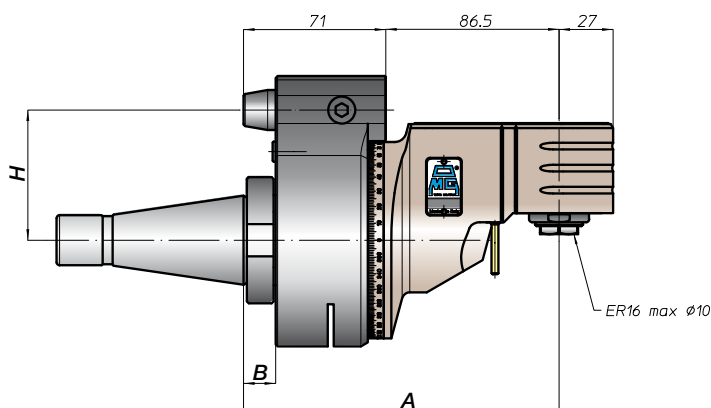
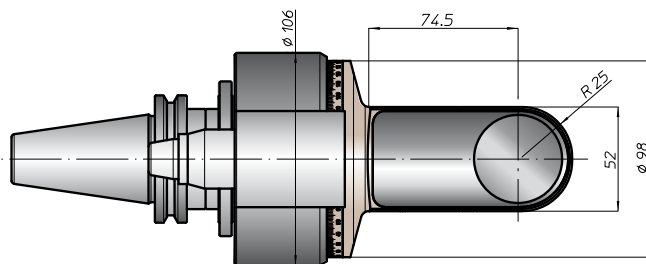
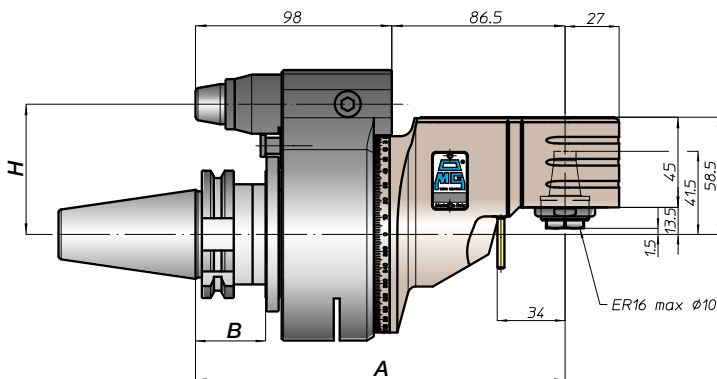
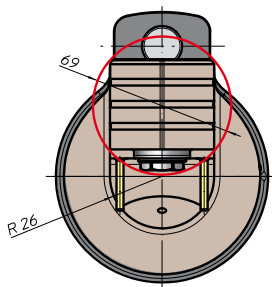

CONO SHANK	size	H			
		A	B	standard	optional
* DIN69871	-			65	-
	40	184,5	35	80	110
	45				
* ANSIB5.50	40			65	-
	50			80	110
* BT	40			65	
	50	192,5	45	80	110
HSK DIN69893	63		44	65	
	80	193,5	46	80	110
	100				
CAPTO ISO26623	C5			65	
	C6	188,5	39		
	C8			80	110
KM	63			65	
	80	184,5		80	110
	100				
DIN2080	-	157,5	13	65	-
	40				
ANSIB5.18	-	160,5	16	80	110
	50				
NMTB	40	157,5	13	65	-
	50	160,5	16	80	110

* Option: Dual Contact



TAO10.PD

caratteristiche/features



peso/weight

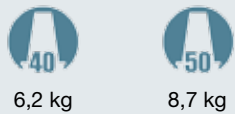

rotazione/rotation



prestazioni/performance

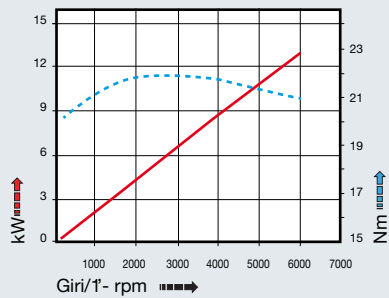

CONO SHANK	size	A	B	H	
				standard	optional
DIN69871 *	-	184,5	35	65	-
	40			80	110
	45			80	110
ANSIB5.50 *	CAT	184,5	35	65	-
				80	110
* BT	40	192,5	45	65	-
	50			80	110
DIN69893 HSK	63	193,5	44	65	-
	80			80	110
	100			80	110
ISO26623 CAPTO	C5	188,5	39	65	-
	C6			80	110
	C8			80	110
KM	63	184,5	35	65	-
	80			80	110
	100			80	110
DIN2080	-	184,5	35	-	-
	-			-	-
	-			-	-
ANSIB5.18 NMTB	-	184,5	35	-	-
	-			-	-

tipi mandrino disponibili / available spindle types

- 2** Albero portafresa / Milling shaft $\varnothing 16$
- 4** DIN69893-HSK **HSK25**

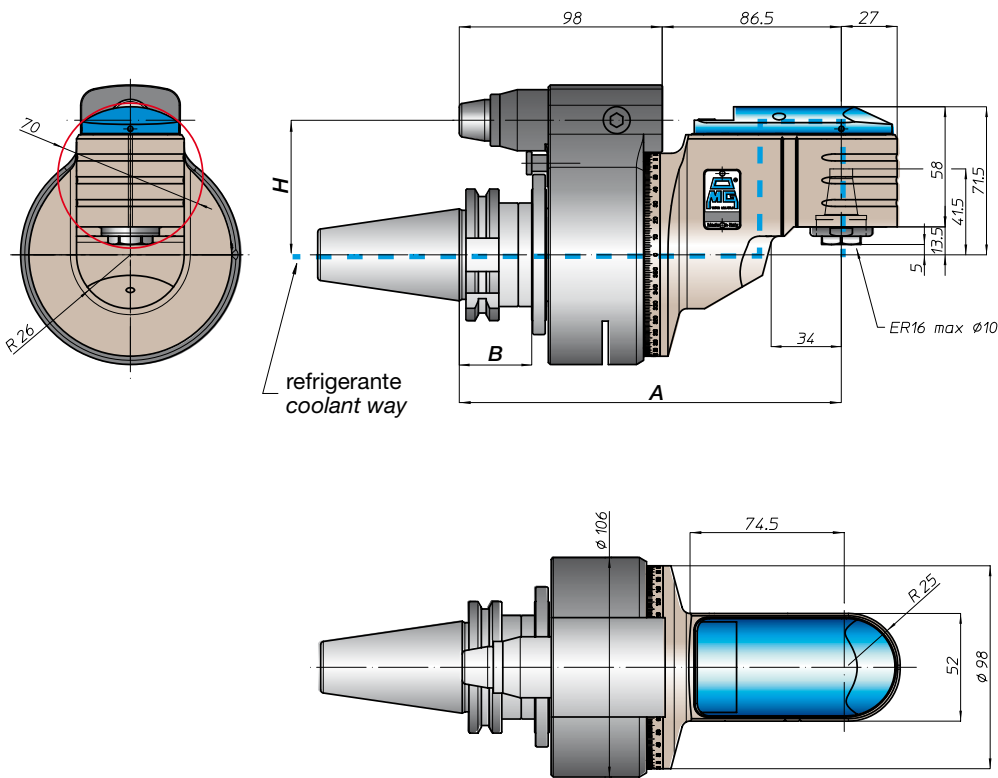

* Option: Dual Contact



BAH
TA.CP
TA
MO
HT
VH
TSI/TSX
T
MT-TC-TC3
Accessori
Accessories
Appendice tecnica
Technical supplement

testa ad angolo - angle head

TAO13.P



caratteristiche/features



ø 13



M10



1-1



4500

peso/weight



7,5 kg



10,5 kg

rotazione/rotation



input



output

prestazioni/performance

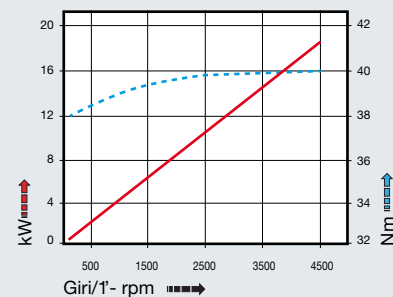

tipi mandrino disponibili / available spindle types

- 2** Albero portafresa
Milling shaft
Ø16
- 3** Weldon
Whistle-Notch
Ø12
- 4** DIN69893-HSK
HSK32

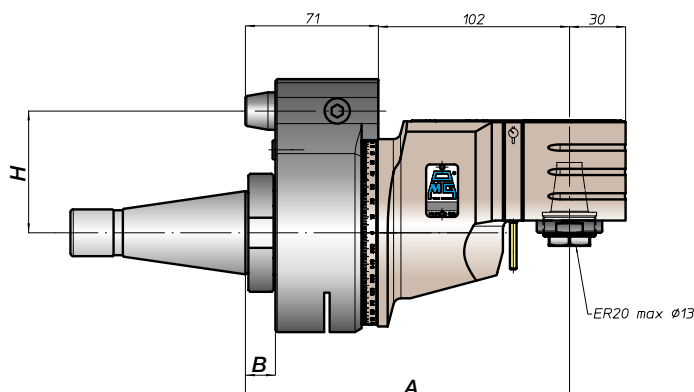
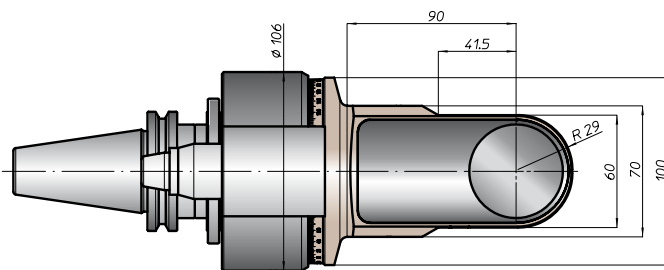
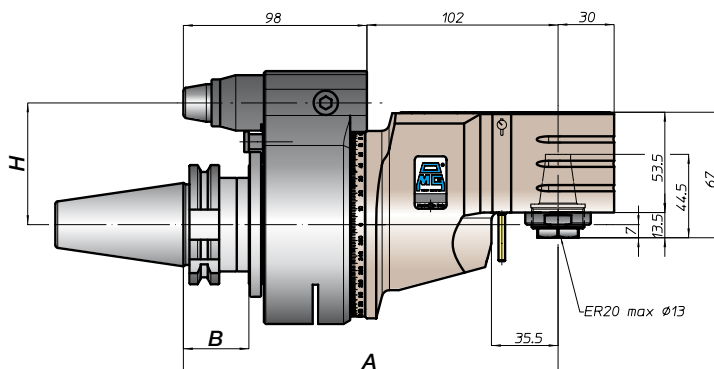
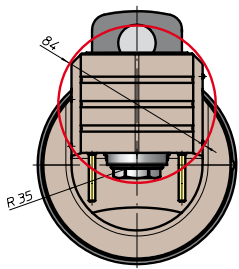

CONO SHANK	size	H			
		A	B	standard	optional
* DIN69871	-			65	-
	40	200	35	80	110
	45			80	110
50	80			110	
* ANSIB5.50 CAT	40			65	-
	50			80	110
* BT	40			65	
	50	208	45	80	110
HSK DIN69893	63		44	65	
	80	209	46	80	110
	100			80	110
CAPTO ISO28623	C5			65	
	C6	204	39	80	110
	C8			80	110
KM	63			65	
	80	200		80	110
	100			80	110
DIN2080	-	170	13	65	-
	40	176	16	80	110
50	80			110	
ANSIB5.18 NMTB	40	173	13	65	-
	50	176	16	80	110

* Option: Dual Contact

BAH
TA-CP
TA
MO
HT
VH
TSI/TSX
T
MT-TC-TC3
Accessori
Accessories
Appendice tecnica
Technical supplement



TAO13.PD

caratteristiche/features



peso/weight

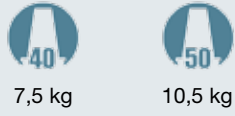

rotazione/rotation



prestazioni/performance

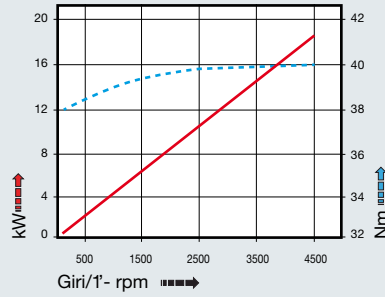

CONO SHANK	size	A	B	H	
				standard	optional
DING9871 *	-	200	35	65	-
	40			80	110
	45			80	110
ANSIB5.50 *	40	208	45	65	-
	50			80	110
BT *	40	204	39	65	-
	50			80	110
HSK	63	209	46	65	-
	80			80	110
	100			80	110
CAPTO	C5	204	39	65	-
	C6			80	110
	C8			80	110
KM	63	200	-	65	-
	80			80	110
	100			80	110
DIN2080	-	-	-	-	-
	-			-	-
	-			-	-
NMTB	-	-	-	-	-
	-			-	-

tipi mandrino disponibili / available spindle types

- 2** Albero portafresa Milling shaft \varnothing 16
- 3** Weldon Whistle-Notch \varnothing 12
- 4** DIN69893-HSK HSK32

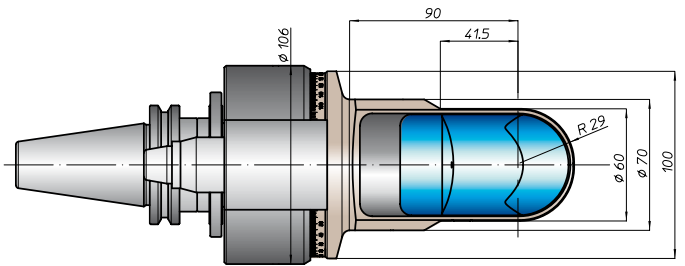
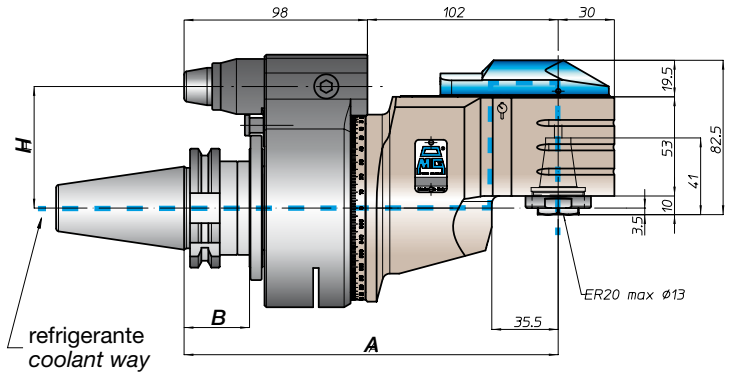
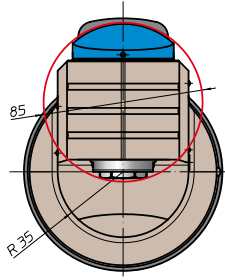

* Option: Dual Contact



TAO16.P



caratteristiche/features



peso/weight



11,7 kg

rotazione/rotation



prestazioni/performance

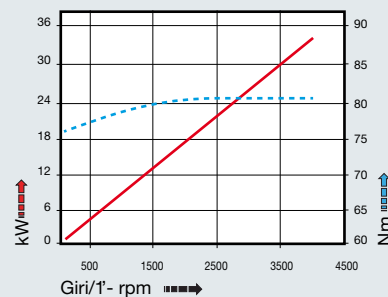

tipi mandrino disponibili / available spindle types

2 Albero portafresa
Milling shaft
Ø16-Ø22-Ø27

3 Weldon
Whistle-Notch
Ø16

4 DIN69893-HSK
HSK40

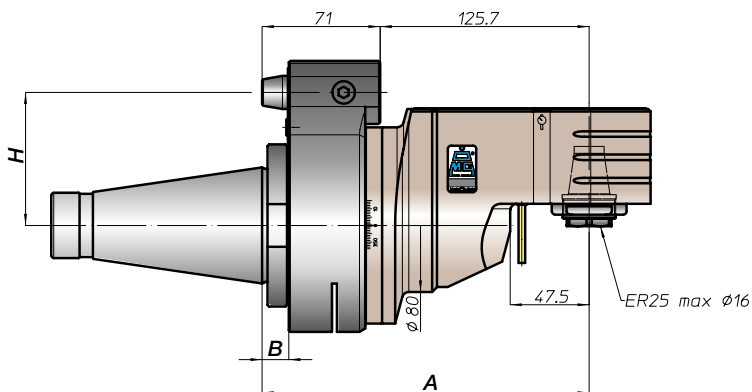
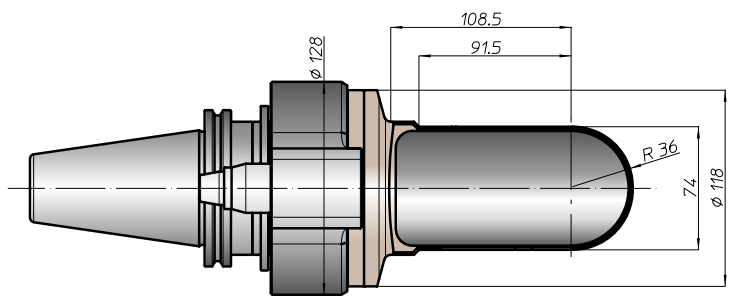
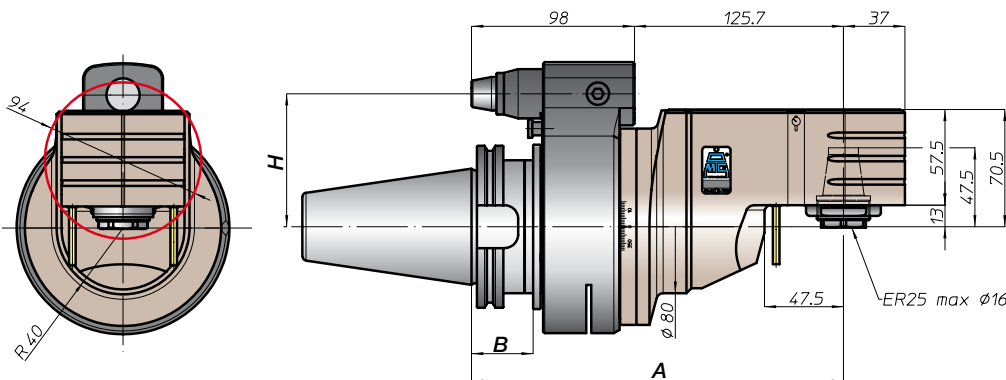

CONO SHANK	size	H			
		A	B	standard	optional
DING9871 *	-	-	-	-	-
ANSIB5.50 *	45	223,5	35	80	110
	50			65	-
BT *	-	-	-	65	-
	50	231,5	45	80	110
HSK	-	-	-	-	-
	DING9893	80	232,5	46	80
CAPTO	-	-	-	-	-
	ISO28623	-	227,5	-	80
MT-TC-TC3	C8	-	-	80	110
	KM	-	-	-	-
80		223,5	-	80	110
DIN2080	100	-	-	-	-
	-	-	-	-	-
ANSIB5.18	-	-	-	-	-
	50	199,5	16	80	110
NMTB	-	-	-	-	-
	50	199,5	16	80	110

* Option: Dual Contact



TAO16.PD



caratteristiche/features



peso/weight



11,7 kg

rotazione/rotation



input



output

prestazioni/performance

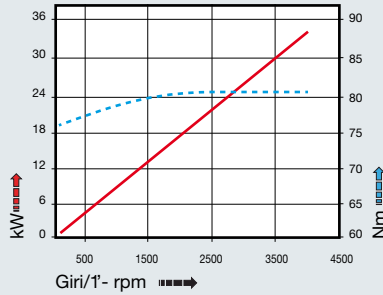

CONO SHANK	size	A	B	H	
				standard	optional
DIN69871 *	-	-	-	-	-
	45	-	-	80	110
	50	223,5	35	80	110
ANSIB5.50 *	-	-	-	65	-
	50	-	-	80	110
* BT	-	-	-	65	-
	50	231,5	45	80	110
HSK	-	-	-	-	-
	DIN69893	80	232,5	46	80
CAPTO	-	-	-	-	-
	ISO26623	-	227,5	-	80
KM	-	-	-	-	-
	80	223,5	-	80	110
DIN2080	-	-	-	-	-
	-	-	-	-	-
NMTB	-	-	-	-	-
	-	-	-	-	-

tipi mandrino disponibili / available spindle types

- 2** Albero portafresa Milling shaft **Ø16-Ø22-Ø27**
- 3** Weldon Whistle-Notch **Ø16**
- 4** DIN69893-HSK **HSK40**

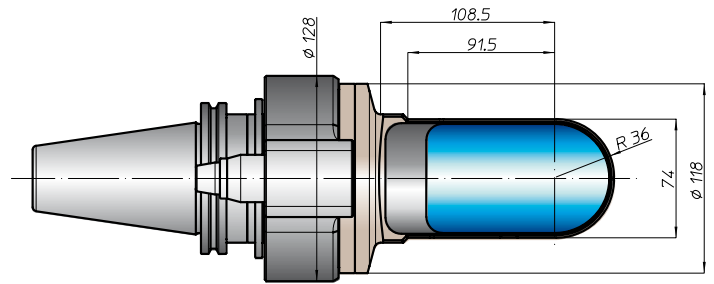
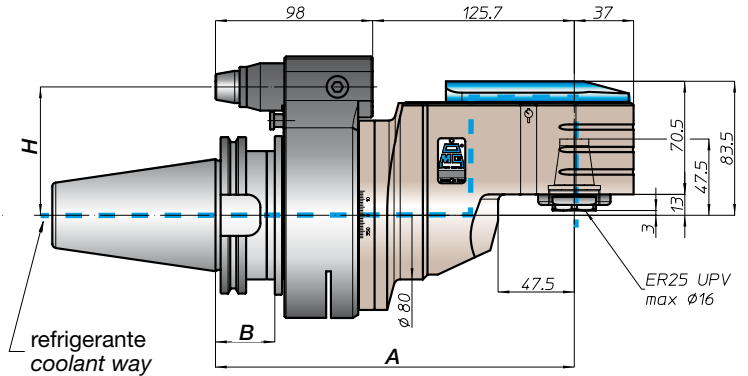
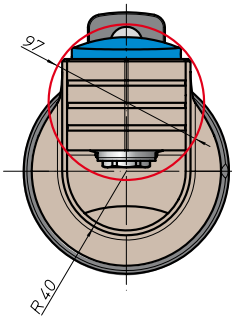

* Option: Dual Contact



testa ad angolo - angle head

TAO20.P



caratteristiche/features



ø 20



M14



1-1



3500

peso/weight



14,5 kg

rotazione/rotation



input



output

prestazioni/performance

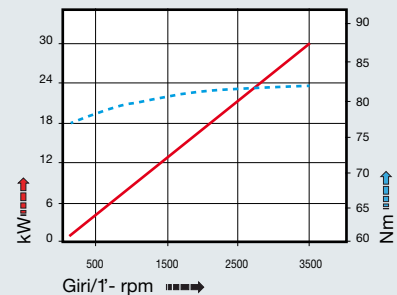

tipi mandrino disponibili / available spindle types

2 Albero portafresa
Milling shaft
Ø22-Ø27-Ø32

3 Weldon
Whistle-Notch
Ø16-Ø20

4 DIN69893-HSK
HSK50

CONO SHANK	size	H			
		A	B	standard	optional
DIN69871 *	-	-	-	-	-
ANSI B5.50 *	45	230	35	80	110
	50			80	110
BT *	-	-	65	-	-
	50	238	45	80	110
HSK	-	-	-	-	-
	DIN69893	80	239	46	80
CAPTO	-	-	-	-	-
	ISO28623	-	234	-	80
KM	-	-	-	-	-
	80	230	-	80	110
DIN2080	-	-	-	-	-
	50	203	16	80	110
ANSI B5.18	-	-	-	-	-
	50	203	16	80	110

* Option: Dual Contact

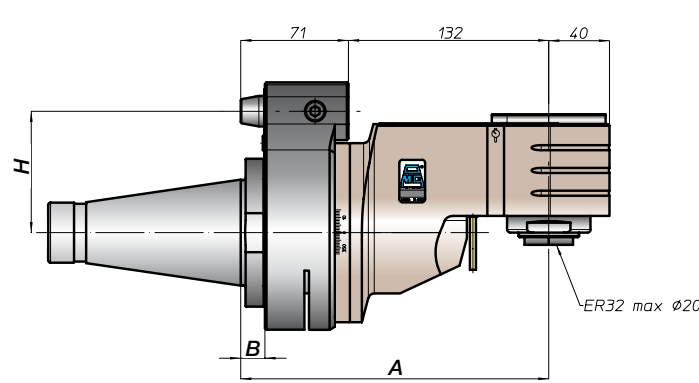
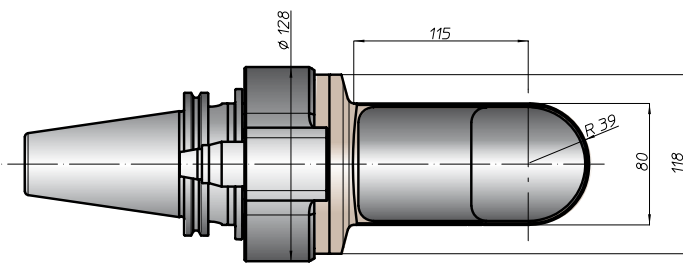
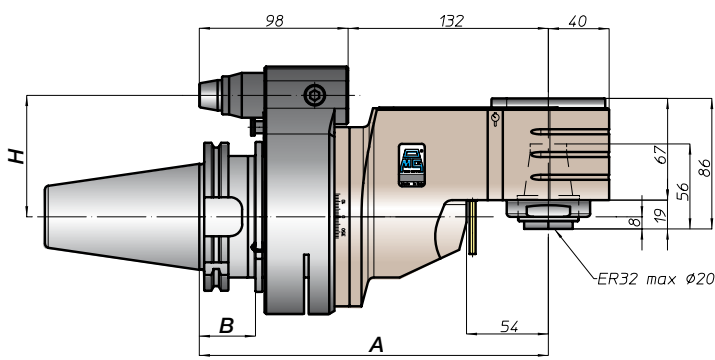
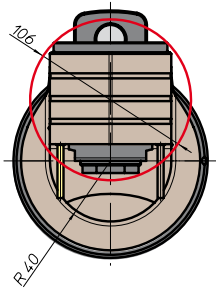

TAO20.PD



caratteristiche/features



peso/weight



14,5 kg

rotazione/rotation



prestazioni/performance

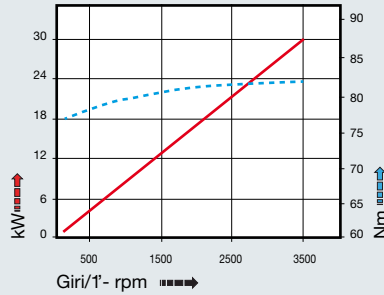

CONO SHANK	size	A	B	H	
				standard	optional
* DING9871	-	230	35	-	-
	45			80	110
	50			80	110
* ANSIB5.50 CAT	-	-	-	-	-
	50	-	-	80	110
* BT	-	-	-	65	-
	50	238	45	80	110
HSK DING9893	-	-	42	-	-
	80	239	46	80	110
	100			80	110
CAPTO ISO26623	-	234	-	-	-
	-		80	110	
	C8		80	110	
KM	-	230	-	-	-
	80		80	110	
	100		80	110	
DIN2080	-	-	-	-	-
	-	-	-	-	-
	-	-	-	-	-
ANSIB5.18 NMTB	-	-	-	-	-
	-	-	-	-	-

tipi mandrino disponibili / available spindle types

- 2** Albero portafresa Milling shaft **3** Weldon Whistle-Notch **4** DIN69893-HSK
- Ø22-Ø27-Ø32** **Ø16-Ø20** **HSK50**

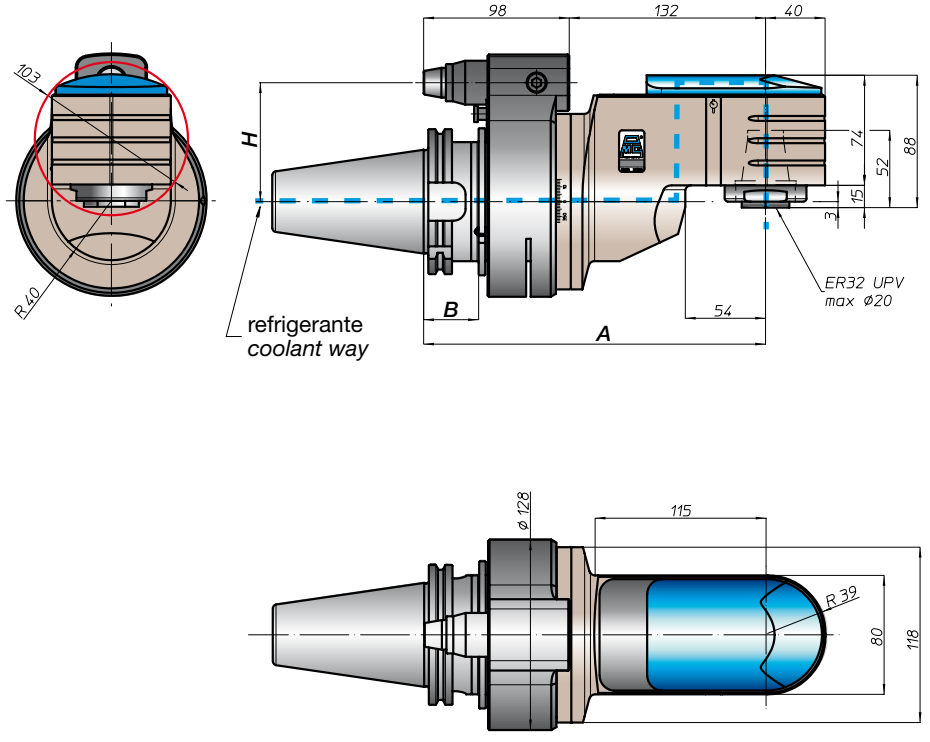

* Option: Dual Contact



BAH
 TA.CP
 TA
 MO
 HT
 VH
 TSI/TSX
 T
 MT-TC-TC3
 Accessori
 Accessories
 Appendice tecnica
 Technical supplement

TAV10.P



caratteristiche/features



ø 10



M8



1-1



4000

peso/weight



6,4 kg



8,5 kg

rotazione/rotation



input



output

prestazioni/performance

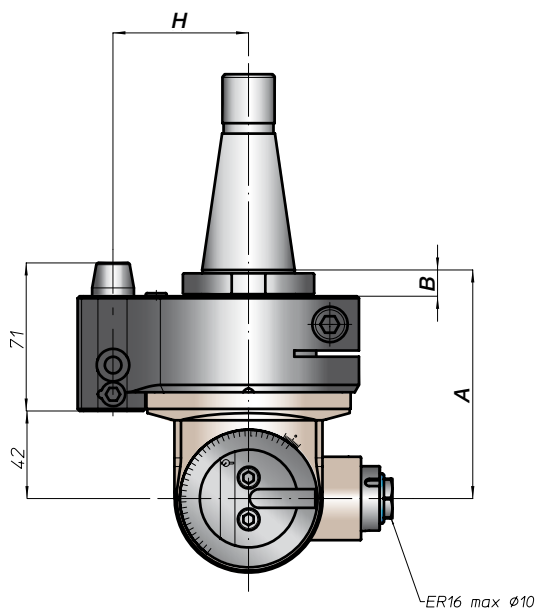
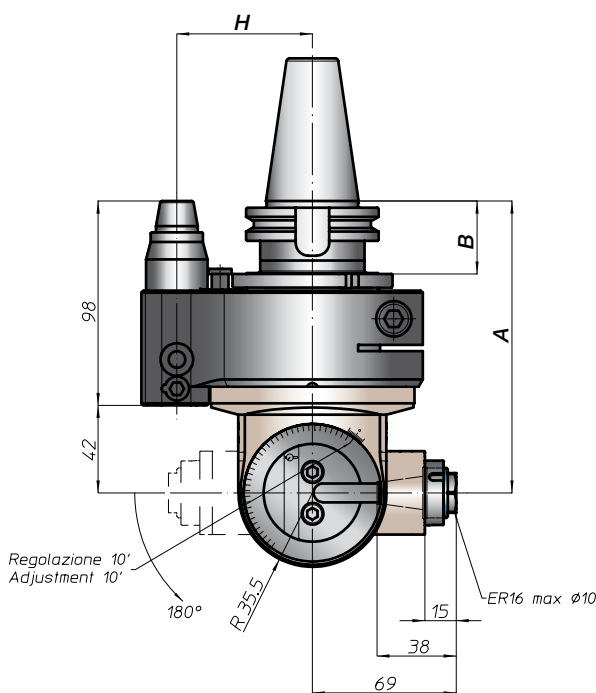
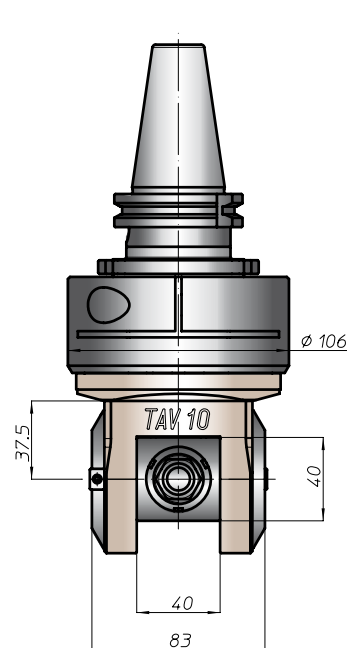
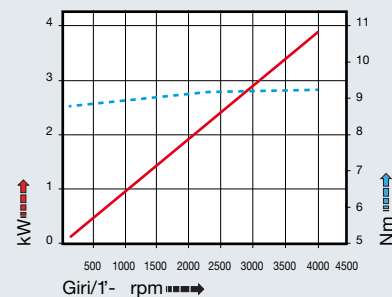

CONO SHANK	size	H			
		A	B	standard	optional
DIN69871 *	-			65	-
	40			80	110
	45			80	110
ANSIB5.50 *	40	140	35	65	-
	50	140	35	80	110
	50	140	35	80	110
* BT	40			65	
	50	148	45	80	110
	50	148	45	80	110
DIN69893	63		44	65	
	80	149		80	110
	100	149	46	80	110
CAPTO	C5			65	
	C6	144	39		
	C8	144	39	80	110
KM	63			65	
	80	140		80	110
	100	140		80	110
DIN2080	-	113	13	65	-
	40	113	13	80	110
	50	116	16	80	110
ANSIB5.18 NMTB	40	113	13	65	-
	50	116	16	80	110

* Option: Dual Contact



TAV10.PD



caratteristiche/features



peso/weight

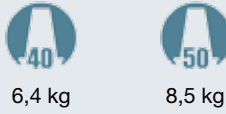

rotazione/rotation



prestazioni/performance

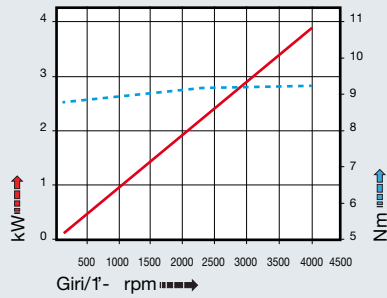

CONO SHANK	size	A	B	H	
				standard	optional
DIN69871 *	-	140	35	65	-
	40			80	110
	45			80	110
ANSI B5.50 *	CAT	148	45	65	-
	BT			80	110
DIN69893	HSK	149	46	65	-
	80			80	110
	100			80	110
ISO26623	C5	144	39	65	-
	C6			80	110
	C8			80	110
KM	63	140	-	65	-
	80			80	110
	100			80	110
DIN2080	-	-	-	-	-
	-	-	-	-	-
	-	-	-	-	-
ANSI B5.18	NMTB	-	-	-	-
	-	-	-	-	-

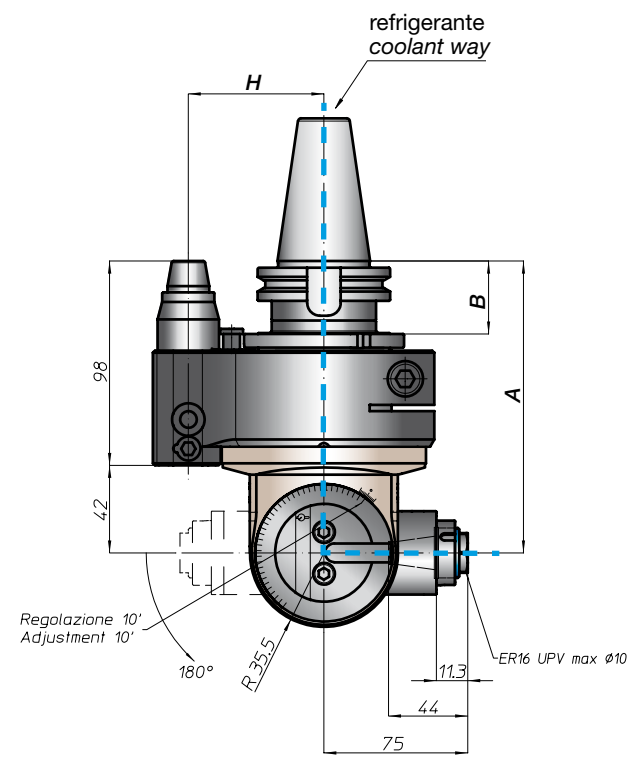
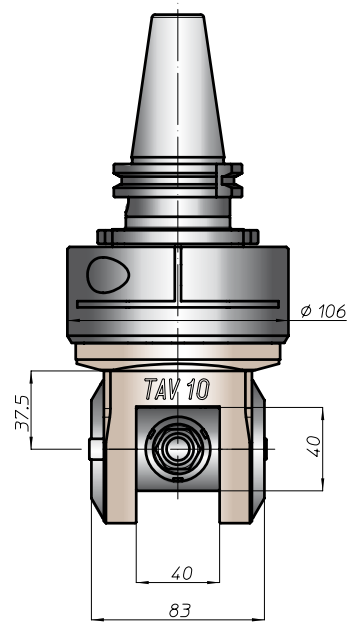

* Option: Dual Contact

BAH
TA.CP
TA
MO
HT
VH
TSI/TSX
T
MT-TC-TC3
Accessori
Accessories
Appendice tecnica
Technical supplement



testa ad angolo - angle head

TAV13.P



caratteristiche/features



ø 13



M10



1-1



3000

peso/weight



7,8 kg



10,5 kg

rotazione/rotation



input



output

prestazioni/performance

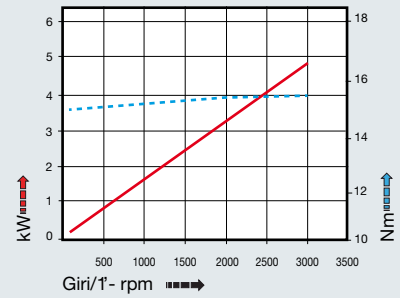

tipi mandrino disponibili / available spindle types

- 1** DIN6388-ER
ER25
- 3** Weldon Whistle-Notch
Ø16

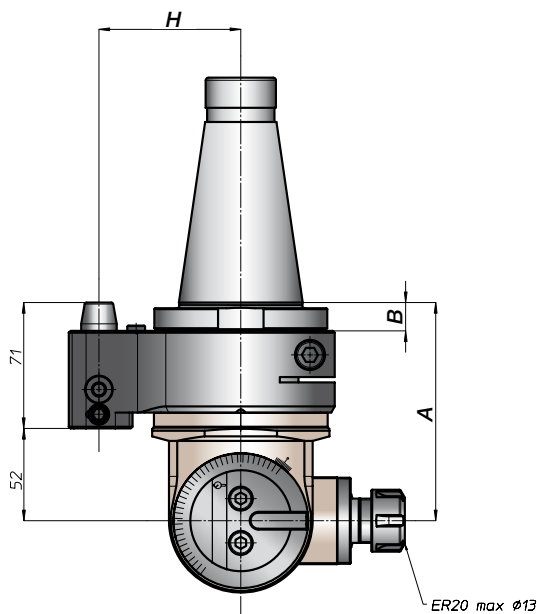
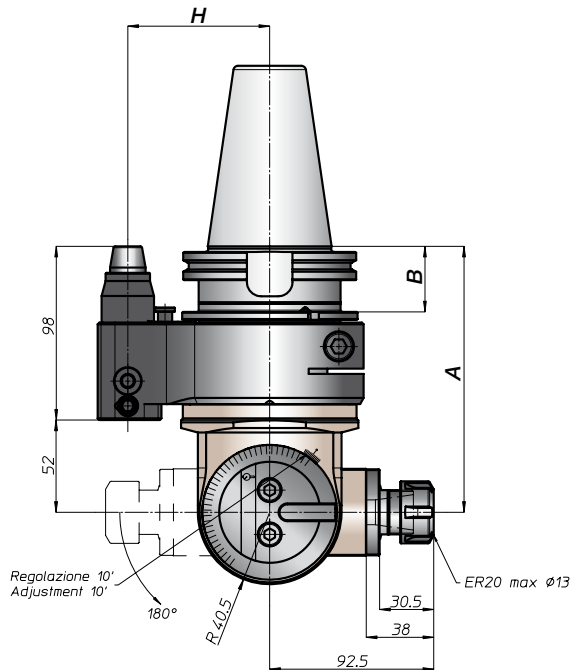
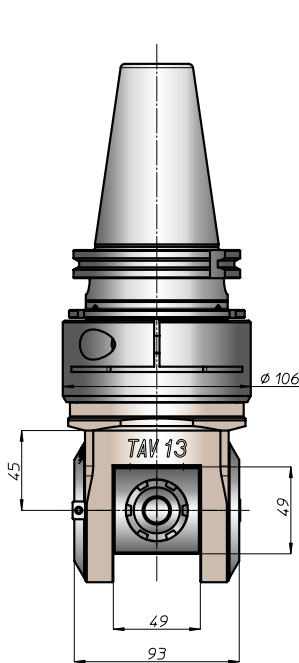

CONO SHANK	size	H			
		A	B	standard	optional
DIN69871 *	-	150	35	65	-
	40			80	110
	45			80	110
ANSIB5.50 *	CAT	150	35	65	-
	50			80	110
* BT	40	158	45	65	-
	50			80	110
DIN69893	HSK	159	46	65	-
	80			80	110
	100			80	110
ISO26623	C5	154	39	65	-
	C6			80	110
	C8			80	110
KM	63	150	35	65	-
	80			80	110
	100			80	110
DIN2080	-	120	13	65	-
	40			80	110
	50			80	110
ANSIB5.18 NMTB	40	120	16	65	-
	50			80	110

* Option: Dual Contact



TAV13.PD



caratteristiche/features



peso/weight

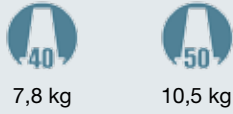

rotazione/rotation



prestazioni/performance

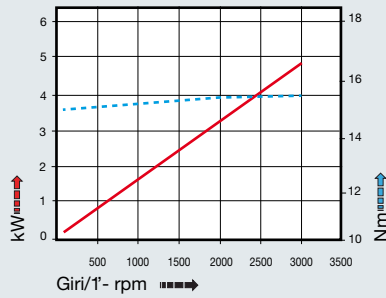

CONO SHANK	size	A	B	H	
				standard	optional
* DIN69871 *	-	150	35	65	-
	40			80	110
	45			80	110
* ANSIB5.50 *	40	150	35	65	-
	50			80	110
* BT	40	158	45	65	-
	50			80	110
DIN69893	63	159	42	65	-
	80		46	80	110
	100		46	80	110
CAPTO	C5	154	39	65	-
	C6			80	110
	C8			80	110
KM	63	150	35	65	-
	80			80	110
	100			80	110
DIN2080	-	120	13	65	-
	40			-	-
	-			-	-
ANSIB5.18	NMTB	-	-	-	-
	-	-	-	-	-

tipi mandrino disponibili / available spindle types

1 DIN6388-ER ER25 3 Weldon Whistle-Notch Ø16

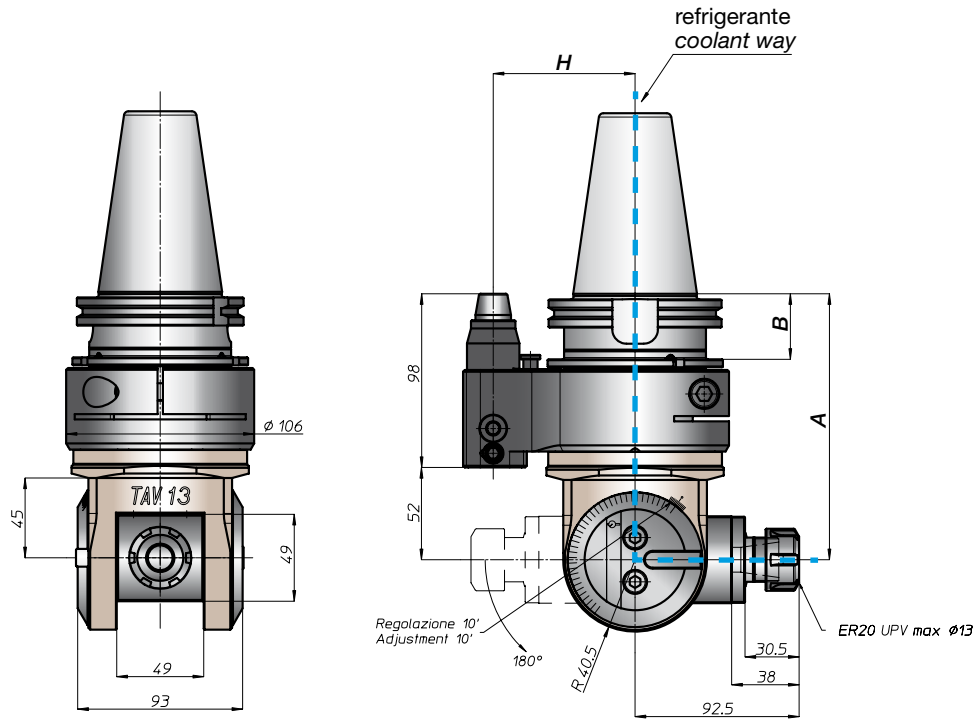

* Option: Dual Contact

BAH
TA.CP
TA
MO
HT
VH
TSI/TSX
T
MT-TC-TC3
Accessori
Accessories
Appendice tecnica
Technical supplement



testa ad angolo - angle head

TAV20.P



caratteristiche/features



ø 20



M16



1-1



2500

peso/weight



22 kg

rotazione/rotation



input



output

prestazioni/performance

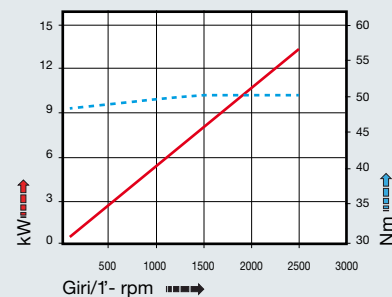

tipi mandrino disponibili / available spindle types

- 1** DIN6388-ER
ER40
- 2** Albero portafresa
Milling shaft
Ø32
- 3** Weldon
Whistle-Notch
Ø20-Ø25
- 4** DIN69893-HSK
HSK50
- 6** ABS
Licenza KOMET®
ABS50

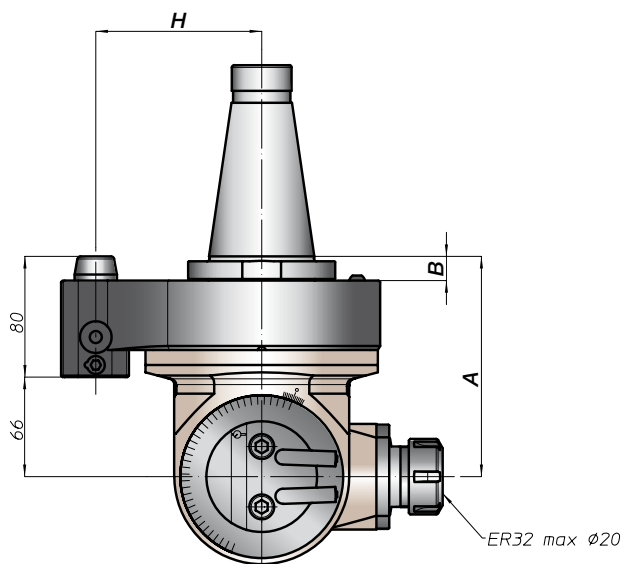
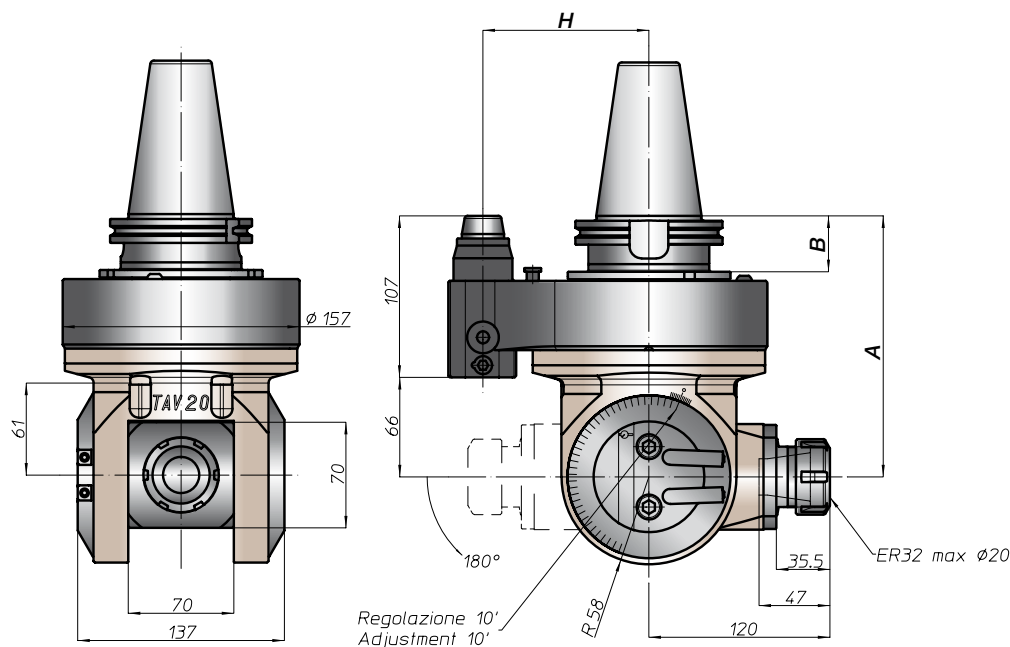

CONO SHANK	size	H			
		A	B	standard	optional
DIN69871 *	-	-	-	-	-
DIN69871 *	-	-	-	110	-
DIN69871 *	50	173	35	110	-
ANSIB5.50 *	-	-	-	-	-
ANSIB5.50 *	50	-	-	110	-
BT *	-	-	-	-	-
BT *	50	181	45	110	-
HSK	-	-	-	-	-
DIN69893	80	182	-	110	-
DIN69893	100	-	46	110	-
CAPTO	-	-	-	-	-
ISO28623	-	177	-	110	-
ISO28623	C8	-	-	110	-
KM	-	-	-	-	-
KM	-	173	-	110	-
KM	100	-	-	110	-
DIN2080	-	-	-	-	-
DIN2080	-	-	-	-	-
DIN2080	50	149	16	110	-
NMTB	-	-	-	-	-
ANSIB5.18	50	149	16	110	-

* Option: Dual Contact



TAV20.PD



caratteristiche/features



peso/weight



22 kg

rotazione/rotation



prestazioni/performance

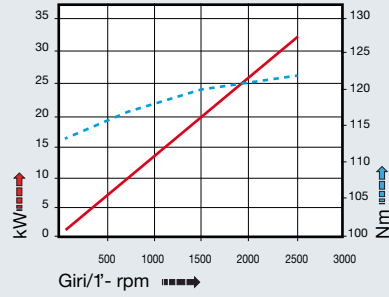

CONO SHANK	size	A	B	H	
				standard	optional
* DING69871 *	-	173	35	-	-
	50			110	-
* ANSIB5.50 *	-	173	35	-	-
	50			110	-
* BT	-	181	45	-	-
	50			110	-
HSK	-	182	46	-	-
	80			110	-
DING69893	-	177	-	-	-
	100			110	-
CAPTO	-	177	-	-	-
	C8			110	-
KM	-	173	-	-	-
	100			110	-
DIN2080	-	-	-	-	-
	-			-	-
	-			-	-
ANSIB5.18 NMTB	-	-	-	-	-
	-			-	-

tipi mandrino disponibili / available spindle types

- 1** DIN6388-ER
ER40
- 3** Weldon Whistle-Notch
Ø20-Ø25
- 4** DIN69893-HSK
HSK50
- 6** ABS Licenza KOMET®
ABS50

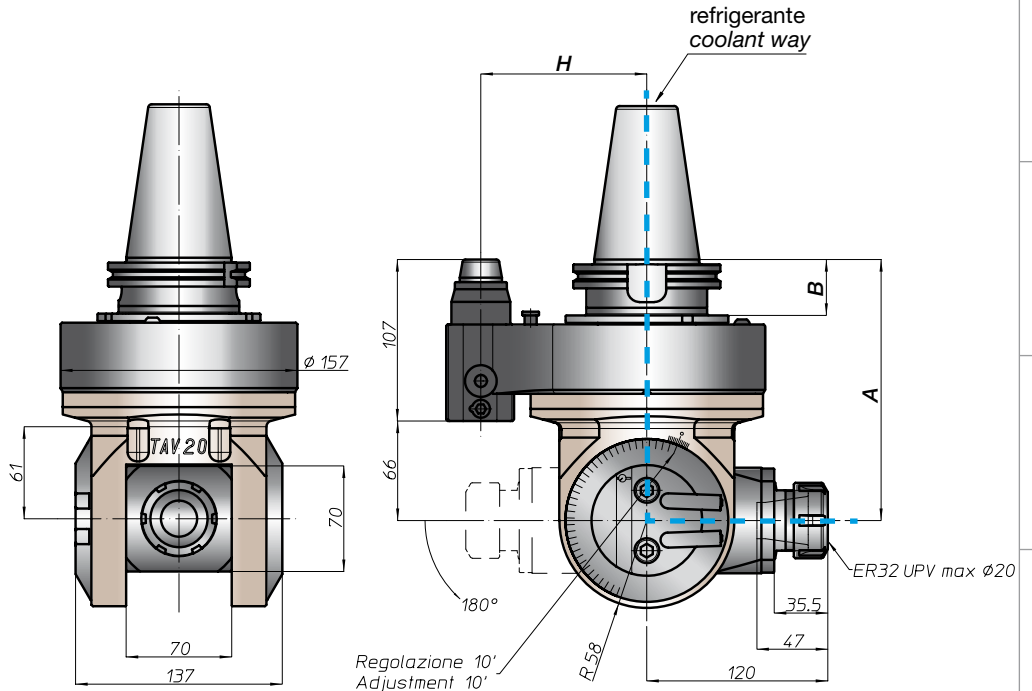

* Option: Dual Contact



BAH
TA.CP
TA
MO
HT
VH
TSI/TSX
T
MT-TC-TC3
Accessori
Accessories
Appendice tecnica
Technical supplement

TAV30.P



caratteristiche/features



peso/weight



rotazione/rotation



prestazioni/performance

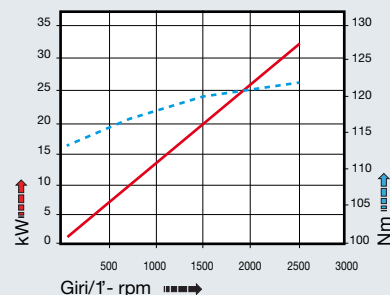

tipi mandrino disponibili / available spindle types

- 1** DIN6388-ER
ER50
- 2** Albero portafresa
Milling shaft
Ø32-Ø40
- 4** DIN69893-HSK
HSK63
- 6** ABS
Licenza KOMET®
ABS63

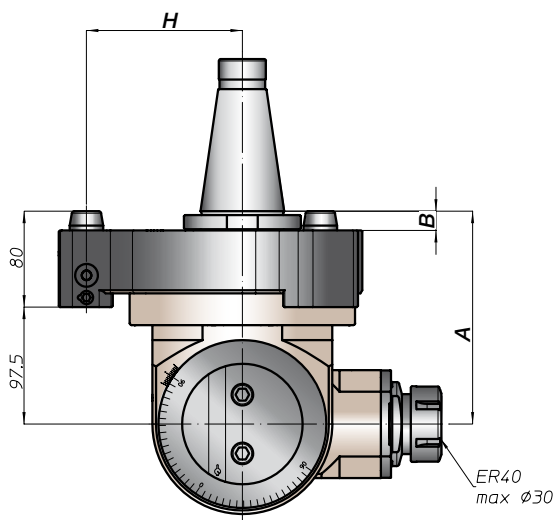
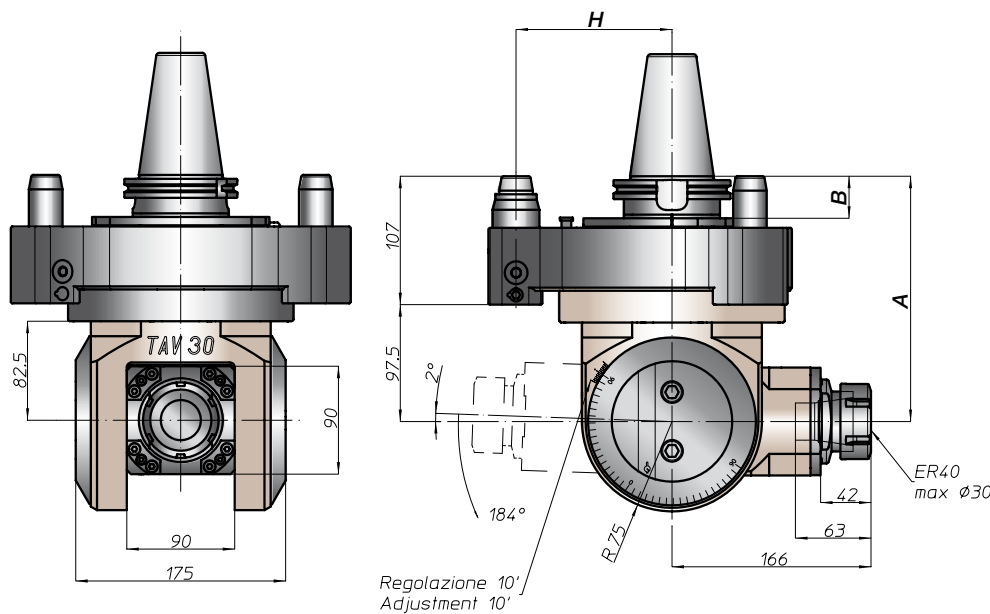

CONO SHANK	size	H			
		A	B	standard	optional
DIN69871 *	-	-	-	-	-
DIN69871 *	-	-	-	130	-
DIN69871 *	50	204,5	35	-	-
ANSIB5.50 *	-	-	-	-	-
ANSIB5.50 *	50	-	-	130	-
BT *	-	-	-	-	-
BT *	50	212,5	45	130	-
HSK	-	-	42	-	-
DIN69893	-	213,5	-	-	-
DIN69893	100	-	46	130	-
CAPTO	-	-	-	-	-
ISO26623	-	208,5	-	130	-
ISO26623	C8	-	-	-	-
KM	-	-	-	-	-
KM	-	204,5	-	-	-
KM	100	-	-	130	-
DIN2080	-	-	-	-	-
DIN2080	-	-	-	-	-
DIN2080	50	177,5	16	130	-
NMTB	-	-	-	-	-
ANSIB5.18	50	177,5	16	130	-

* Option: Dual Contact

BAH
TA-CP
TA
MO
HT
VH
TSI/TSX
T
MT-TC-TC3
Accessori
Accessories
Appendice tecnica
Technical supplement



TAV Gallery



BAH

TA.CP

TA

MO

HT

VH

TSI/TSX

T

MT-TG-TC3

Accessori
Accessories

Appendice tecnica
Technical supplement



TAV40.T



caratteristiche/features



ø 32



M26



1-2



5000
OUTPUT

peso/weight



70 kg

rotazione/rotation



input



output

prestazioni/performance

Output data

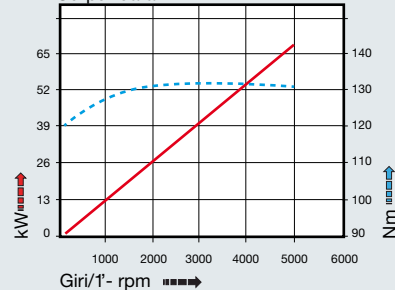

tipi mandrino disponibili / available spindle types

4 DIN69893-HSK
HSK63

5 COROMANT
CAPTO®
C5

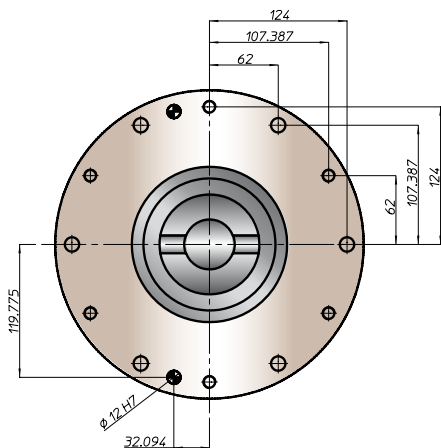
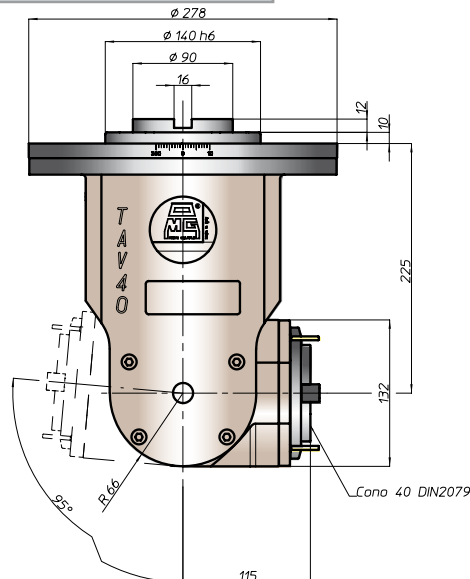
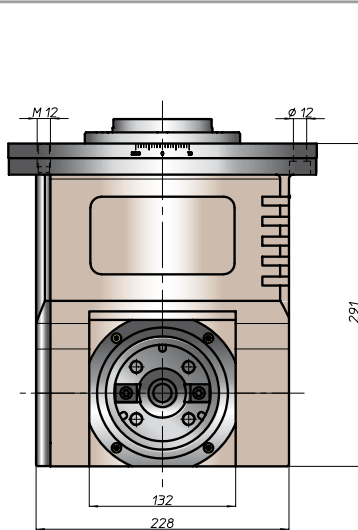

Equipaggiamento standard:

- pressurizzazione mandrino
- n. 4 ugelli orientabili vicino al mandrino
- regolazione angolare mandrino libera
- nel mandrino DIN2079 si possono utilizzare coni DIN2080-40, DIN69871-A40, MAS403-BT40

Standard equipment:

- spindle front pressurization
- nr 4 adjustable nozzle near the spindle
- free angle spindle adjustment
- on the spindle DIN2079 you can use shank DIN2080-40, DIN69871-A40, MAS403-BT40

esempio di collegamento - connection example

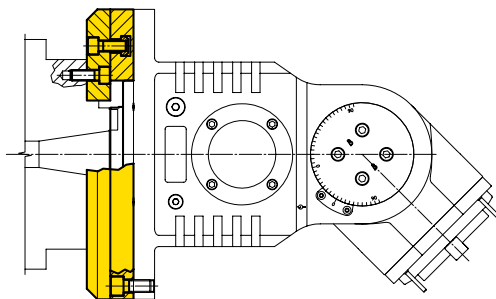

BAH
TA-CP
TA
MO
HT
VH
TSI/TSX
T
MT-TC-TC3
Accessori
Accessories
Appendice tecnica
Technical supplement



TAV50.T



caratteristiche/features



peso/weight



145 kg

rotazione/rotation



prestazioni/performance

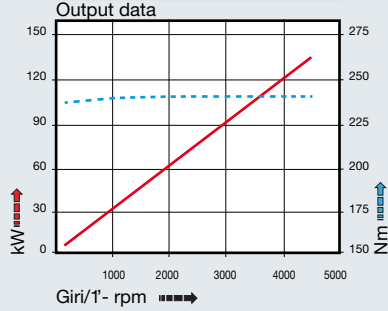

tipi mandrino disponibili / available spindle types

- 4 DIN69893-HSK
A100
- 5 COROMANT CAPTO®
C8

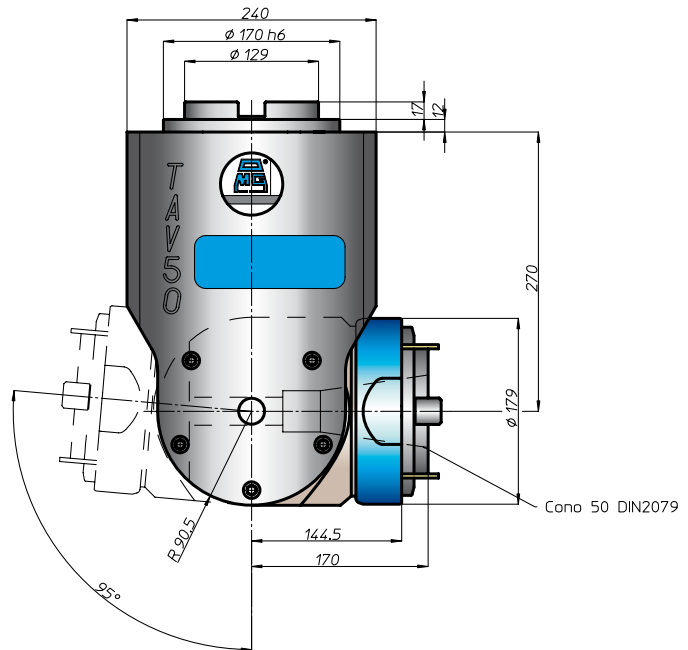
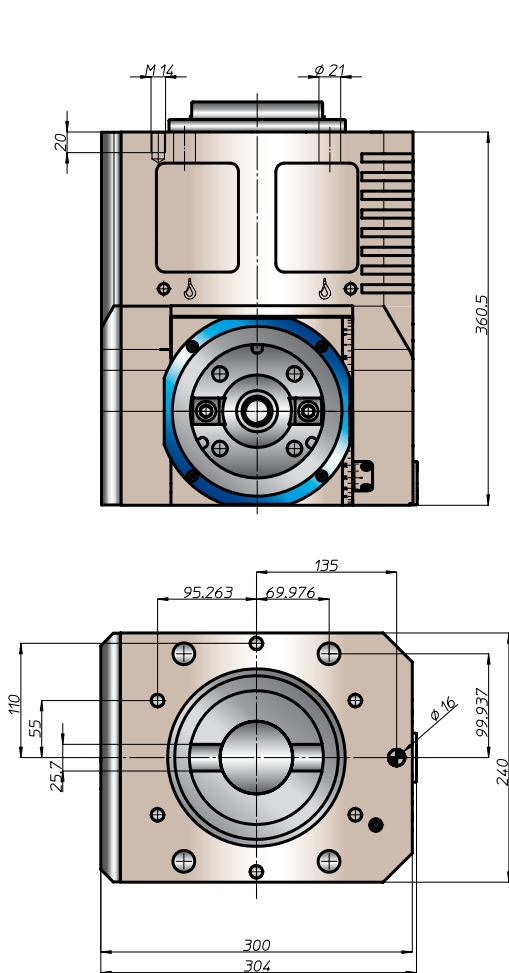

Equipaggiamento standard:

- pressurizzazione mandrino
- n. 4 ugelli orientabili vicino al mandrino
- regolazione angolare mandrino libera o posizionabile ogni 15°
- nel mandrino DIN2079 si possono utilizzare coni DIN69871-A50, MAS403-BT50

Standard equipment:

- spindle front pressurization
- nr 4 adjustable nozzle near the spindle
- free angle spindle adjustment or by pin each 15°
- on the spindle DIN2079 you can use shank DIN69871-A50, MAS403-BT50

esempio di collegamento - connection example

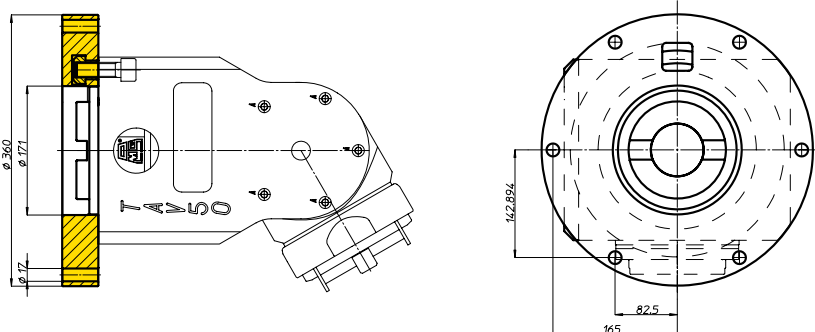

TAF Gallery



BAH

TA-CP

TA

MO

HT

VH

TSI/TSX

T

MT-TC-TC3

Accessori
Accessories

Appendice tecnica
Technical supplement



TAF10.P



caratteristiche/features

peso/weight

prestazioni/performance



rotazione/rotation

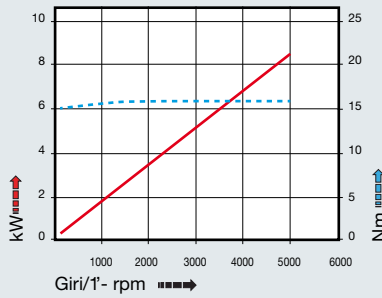

CONO SHANK	size	A	B	H	
				standard	optional
* DING9871	30	132	35	65	-
	40			80	110
	45			80	110
	50			80	110
* ANSIB5.50 CAT	40	132	35	65	-
	50			80	110
* BT	40	140	45	65	-
	50			80	110
HSK DING9893	63	141	42	65	-
	80			80	110
	100			80	110
CAPTO ISO26623	C5	136	39	65	-
	C6			80	110
	C8			80	110
KM	63	132	35	65	-
	80			80	110
	100			80	110
DIN2080	-	132	35	-	-
	-			-	-
	-			-	-
ANSIB5.18 NMTB	-	132	35	-	-
	-			-	-

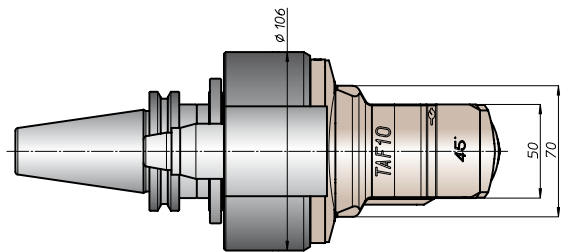
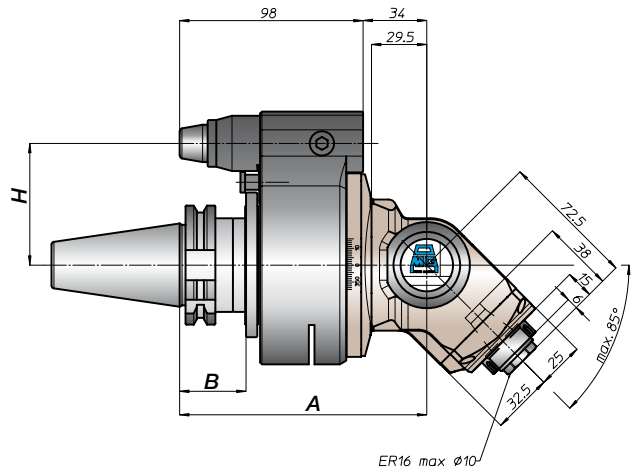
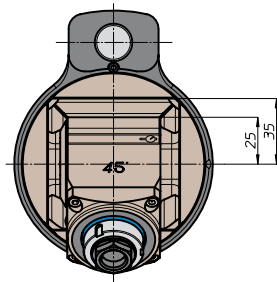

* Option: Dual Contact



testa ad angolo - angle head

TAF13.P



caratteristiche/features



ø 13



M10



1-1



4000

peso/weight



6,5 kg



8,5 kg

rotazione/rotation



input



output

prestazioni/performance

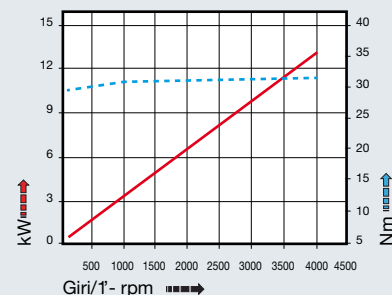

tipi mandrino disponibili / available spindle types

4 DIN69893-HSK
HSK32

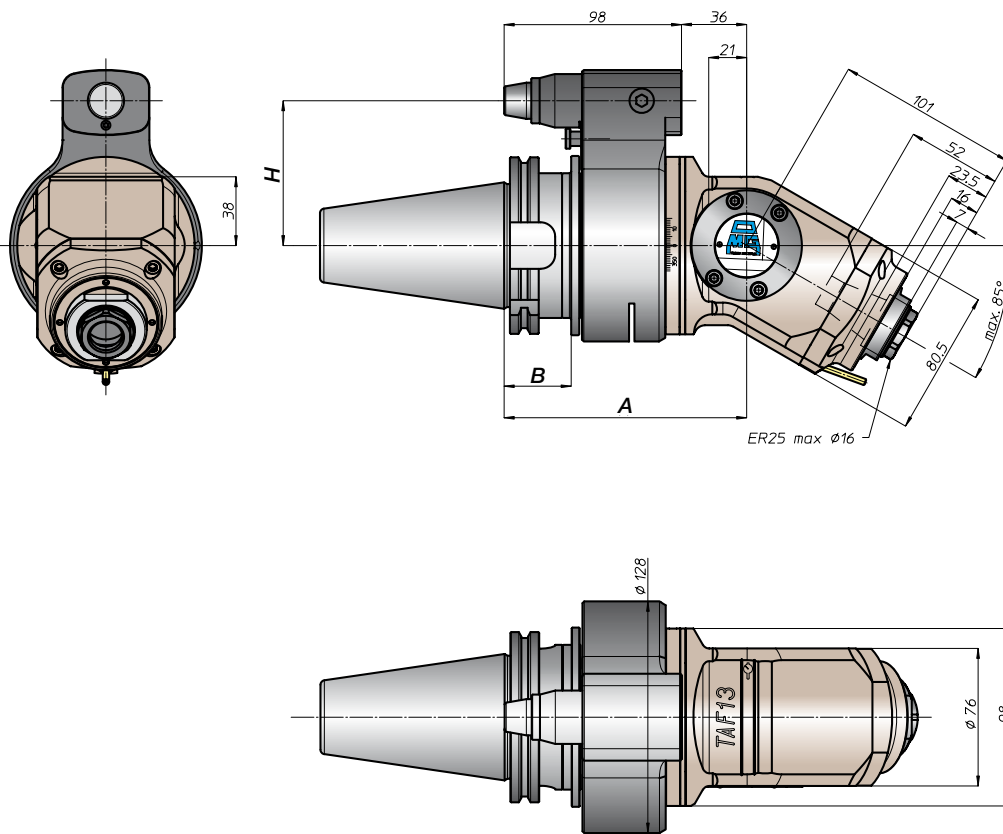

CONO SHANK	size	H			
		A	B	Standard	optional
* DIN69871	-			65	-
	40	134	35	80	110
	45			80	110
50	80			110	
* ANSIB5.50 CAT	40			65	-
	50			80	110
* BT	40			65	
	50	142	45	80	110
HSK DIN69893	63		42	65	
	80	143		80	110
	100		46	80	110
CAPTO ISO26623	C5			65	
	C6	138	39		
	C8			80	110
KM	63			65	
	80	134		80	110
	100			80	110
DIN2080	-			-	-
	-			-	-
	-			-	-
ANSIB5.18 NMTB	-			-	-
	-			-	-

* Option: Dual Contact

BAH
TA-CP
TA
MO
HT
VH
TSI/TSX
T
MT-TC-TC3
Accessori
Accessories
Appendice tecnica
Technical supplement



TAF13.PD



caratteristiche/features



peso/weight

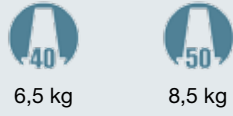

rotazione/rotation



prestazioni/performance

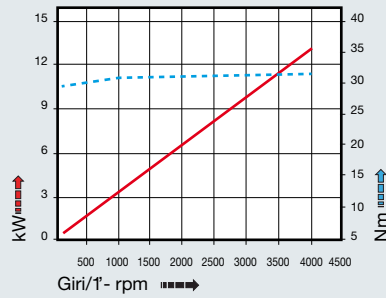

CONO SHANK	size	A	B	H	
				standard	optional
DIN69871 *	-			65	-
	40	134	35	80	110
	45				
50					
ANSIB5.50 * CAT	40			65	-
	50			80	110
* BT	40			65	
	50	142	45	80	110
HSK	63		42	65	
	80	143		80	110
	100		46	80	110
CAPTO	C5			65	
	C6	138	39		
	C8			80	110
KM	63			65	
	80	134		80	110
	100				
DIN2080	-			-	-
	-			-	-
	-			-	-
ANSIB5.18 NMTB	-			-	-
	-			-	-

tipi mandrino disponibili / available spindle types

4 DIN69893-HSK
HSK32

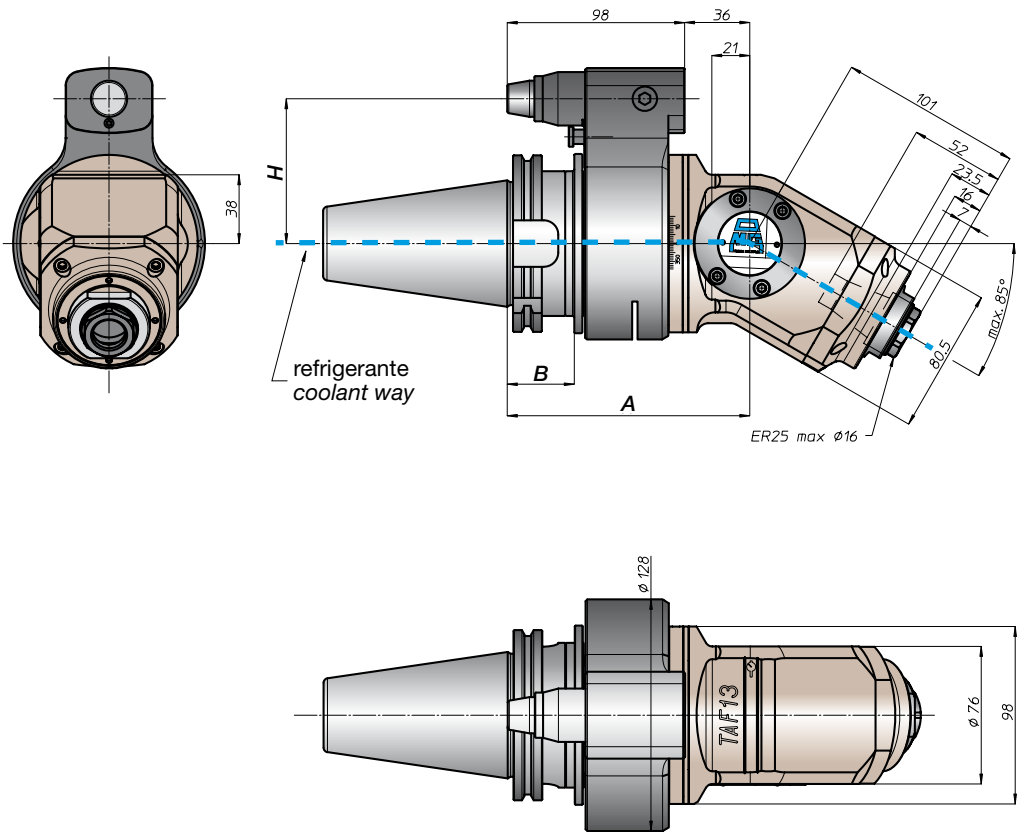

BAH
TA.CP
TA
MO
HT
VH
TSI/TSX
T
MT-TC3
Accessori
Accessories
Appendice tecnica
Technical supplement

* Option: Dual Contact



testa ad angolo - angle head

TAF20.P



caratteristiche/features



ø 20



M16



1-1



3000

peso/weight



13,5 kg

rotazione/rotation



input



output

prestazioni/performance

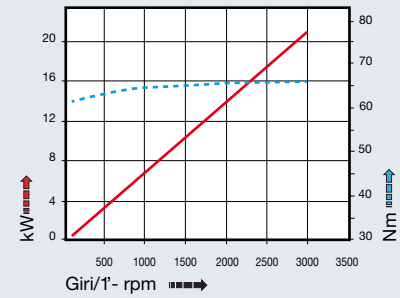

tipi mandrino disponibili / available spindle types

- 1** DIN6388-ER
ER40
- 2** Albero portafresa
Milling shaft
Ø32
- 3** Weldon
Whistle-Notch
Ø20
- 4** DIN69893-HSK
HSK50
- 6** ABS
Licenza KOMET®
ABS50

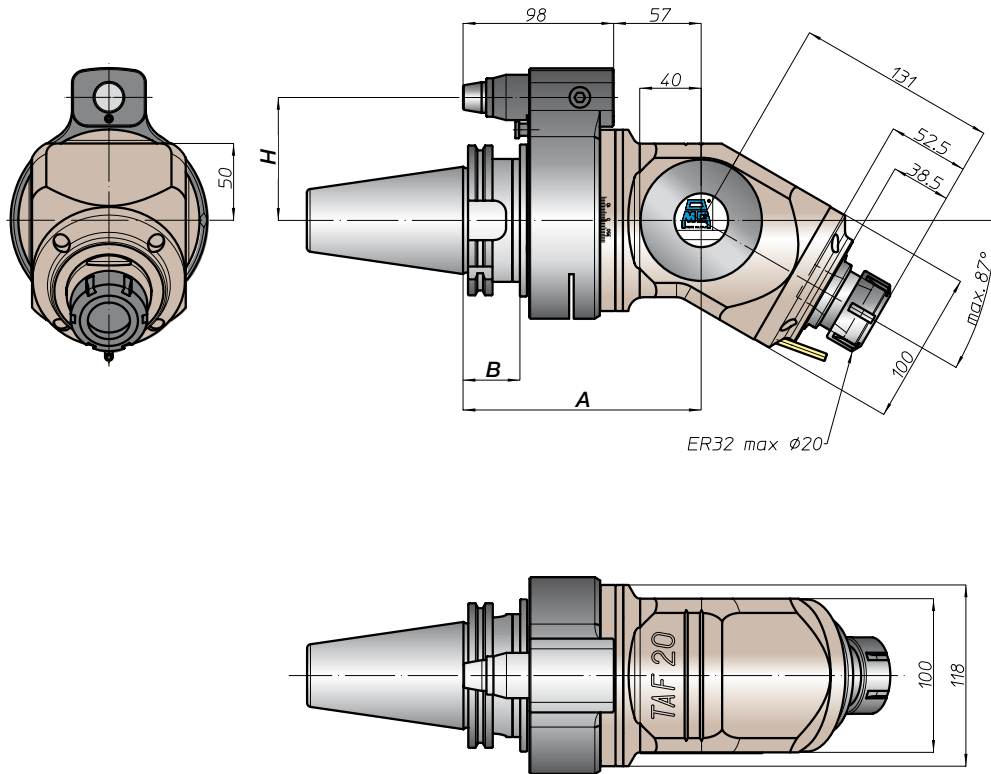

CONO SHANK	size	H			
		A	B	standard	optional
DIN69871 *	-	-	-	-	-
DIN69871 *	45	-	-	80	110
DIN69871 *	50	155	35	80	110
ANSIB5.50 *	-	-	-	-	-
ANSIB5.50 *	50	-	-	80	110
BT *	-	-	-	-	-
BT *	50	163	45	80	110
HSK	-	-	42	-	-
DIN69893	80	164	-	80	110
DIN69893	100	-	46	80	110
CAPTO	-	-	-	-	-
ISO26623	C6	159	-	80	110
ISO26623	C8	-	-	80	110
KM	-	-	-	-	-
KM	80	155	-	80	110
KM	100	-	-	80	110
DIN2080	-	-	-	-	-
DIN2080	-	-	-	-	-
DIN2080	-	-	-	-	-
NMTB	-	-	-	-	-
ANSIB5.18	-	-	-	-	-
ANSIB5.18	-	-	-	-	-

* Option: Dual Contact

BAH

TA-CP

TA

MO

HT

VH

TSI/TSX

T

MT-TC-TC3

Accessori
Accessories

Appendice tecnica
Technical supplement



TAF20.PD

caratteristiche/features



peso/weight



13,5 kg

rotazione/rotation



prestazioni/performance

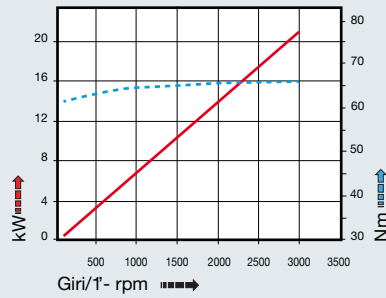

CONO SHANK	size	A	B	H	
				standard	optional
 DIN69871 *	-	155	35	-	-
	45			80	110
	50			80	110
 ANSIB5.50 * CAT	-	155	35	-	-
	50			80	110
 * BT	-	163	45	80	110
	50			80	110
 HSK DIN69893	-	164	42	-	-
	80		80	110	
	100		80	110	
 CAPTO ISO26623	-	159	-	-	-
	C6		80	110	
 KM	-	155	-	-	-
	80		80	110	
	100		80	110	
 DIN2080	-	155	-	-	-
	-		-	-	
	-		-	-	
 NMTB ANSIB5.18	-	155	-	-	-
	-		-	-	

tipi mandrino disponibili / available spindle types

- 1** DIN6388-ER
ER40
- 3** Weldon Whistle-Notch
Ø20
- 4** DIN69893-HSK
HSK50
- 6** ABS Licenza KOMET®
ABS50

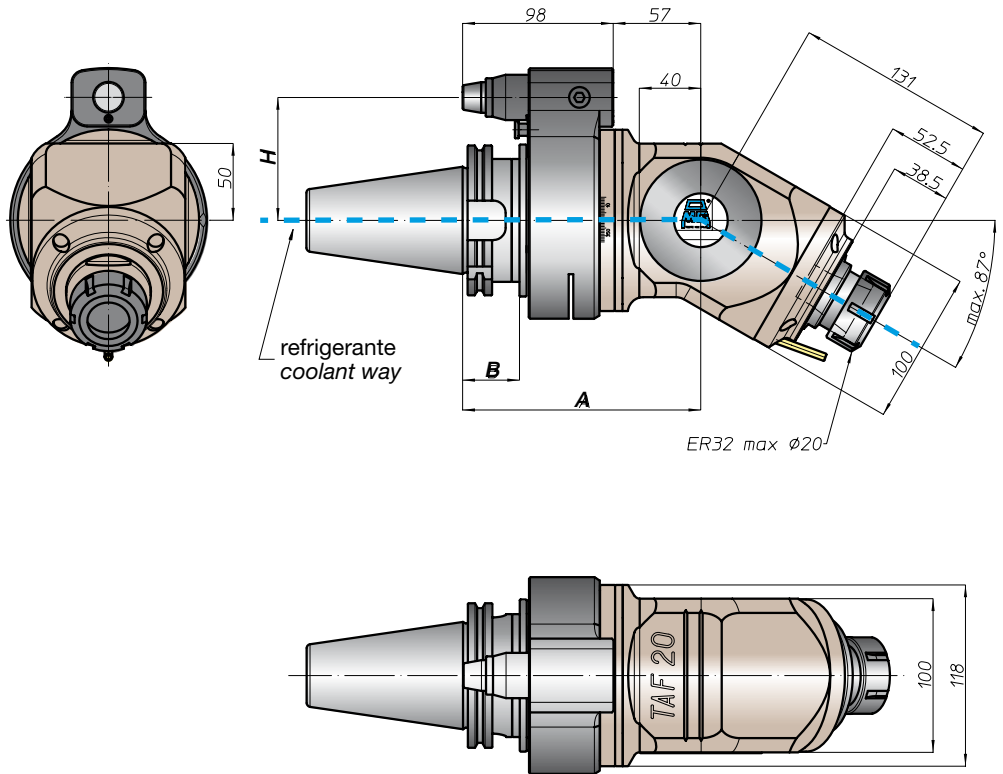

* Option: Dual Contact



BAH
 TA.CP
 TA
 MO
 HT
 VH
 TSI/TSX
 T
 MT-TC-TC3
 Accessori
 Accessories
 Appendice tecnica
 Technical supplement

TA07P.T



caratteristiche/features



peso/weight



rotazione/rotation



prestazioni/performance

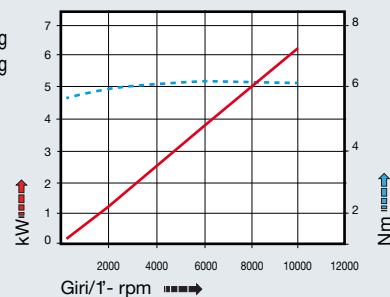

tipi mandrino disponibili / available spindle types

3 Weldon Whistle-Notch
Ø8-Ø10

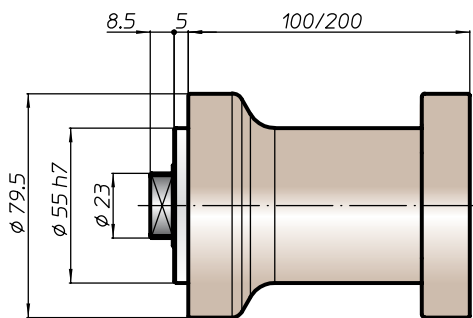
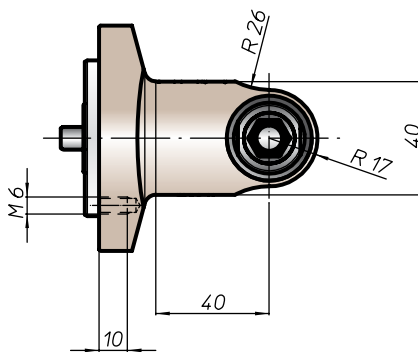

Prolunga
Extension

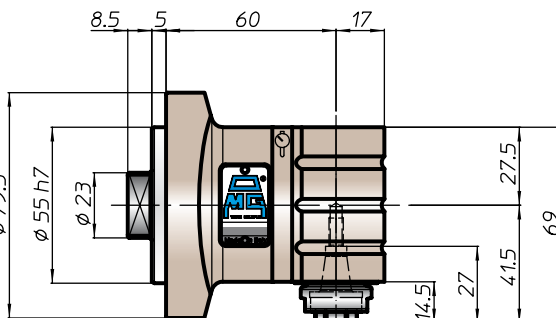

ER11 max ø 7

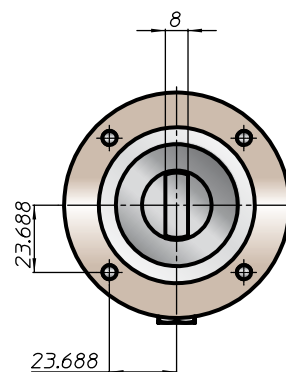

esempio di collegamento - connection example

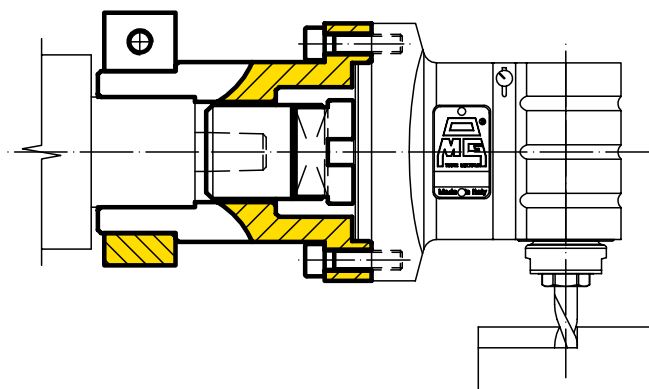

TA10P.T

caratteristiche/features



peso/weight



rotazione/rotation

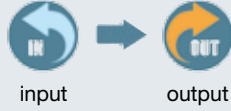

prestazioni/performance

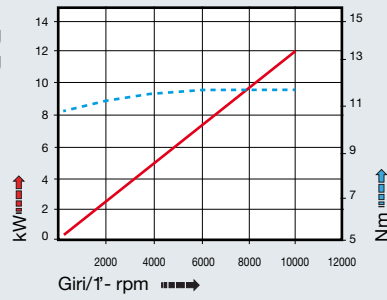

tipi mandrino disponibili / available spindle types

- | | | |
|---------------------|---|----------------------------------|
| 1 DIN6388-ER | 2 Albero portafresa
Milling shaft | 3 Weldon
Whistle-Notch |
| ER20 | Ø16 | Ø10 |

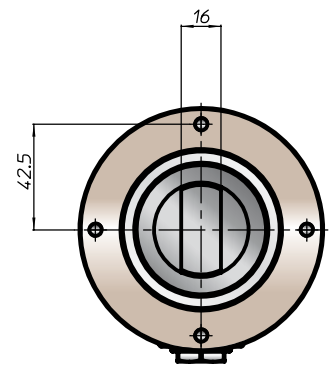
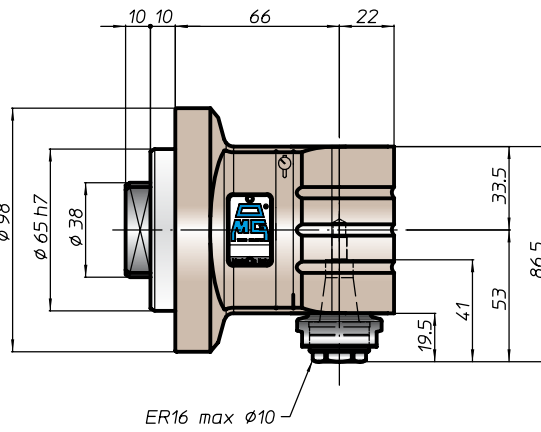
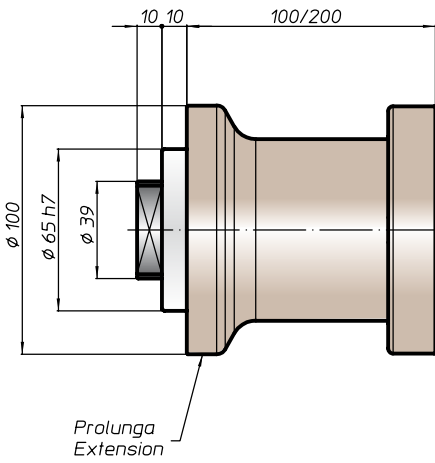
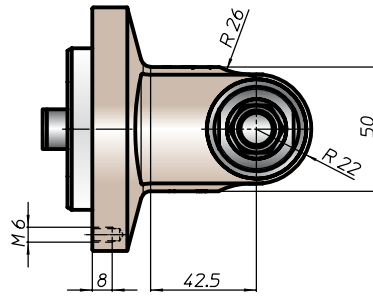

esempio di collegamento - connection example

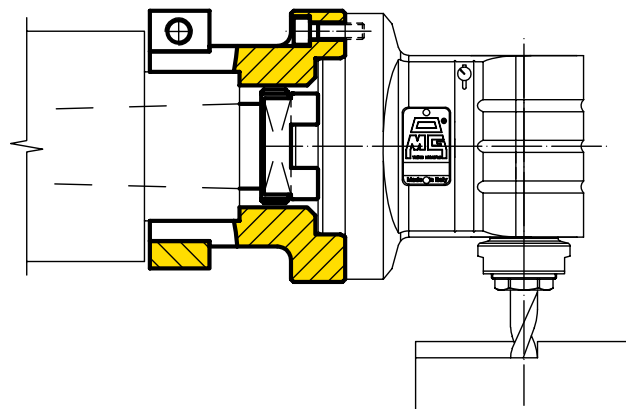

testa ad angolo - angle head

TA13P.T



caratteristiche/features



ø 13



M10



1-1



8000

peso/weight



3,5 kg

rotazione/rotation



input



output

prestazioni/performance

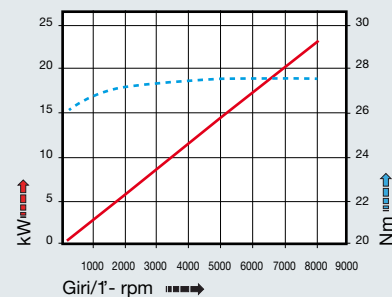

tipi mandrino disponibili / available spindle types

1 DIN6388-ER
ER25

2 Albero portafresa
Milling shaft
Ø16-Ø22

3 Weldon
Whistle-Notch
Ø16

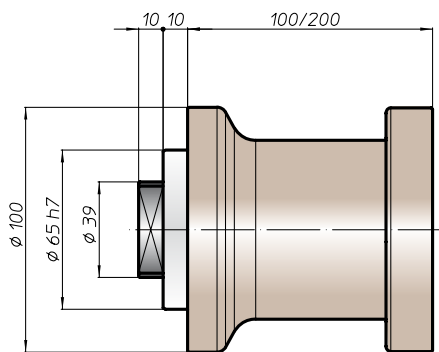
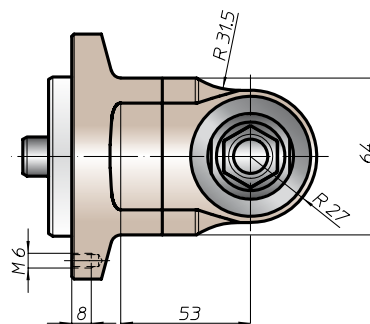

Prolunga
Extension

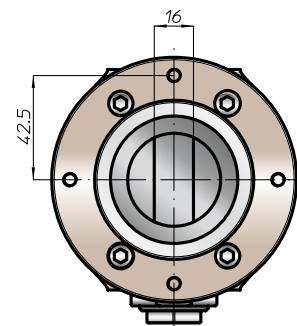
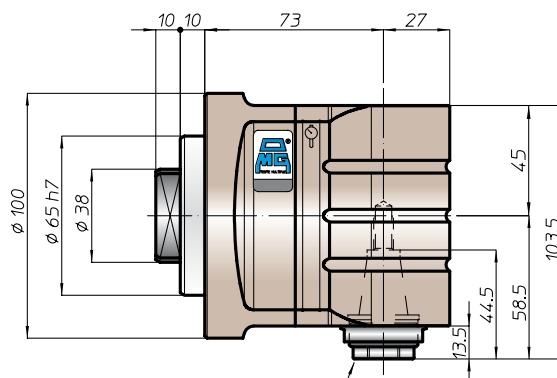

esempio di collegamento - connection example

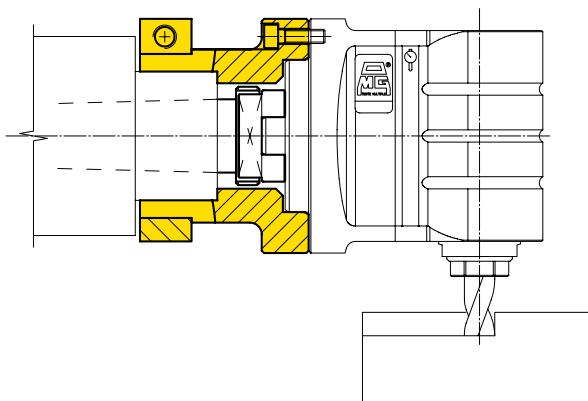

BAH

TA-CP

TA

MO

HT

VH

TSI/TSX

T

MT-TC-TC3

Accessori
Accessories

Appendice tecnica
Technical supplement



TA16P.T

caratteristiche/features



peso/weight



rotazione/rotation



prestazioni/performance

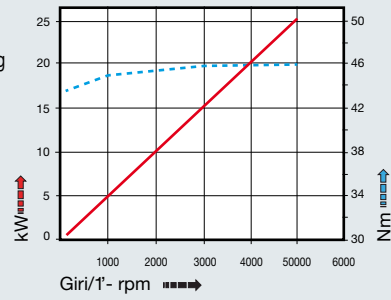

tipi mandrino disponibili / available spindle types

1 DIN6388-ER	2 Albero portafresse Milling shaft	3 Weldon Whistle-Notch	4 DIN69893-HSK	5 COROMANT CAPTO®	6 ABS Licenza KOMET®
ER32	Ø16-Ø22-Ø27-Ø32	Ø20	HSK32	C3	ABS32

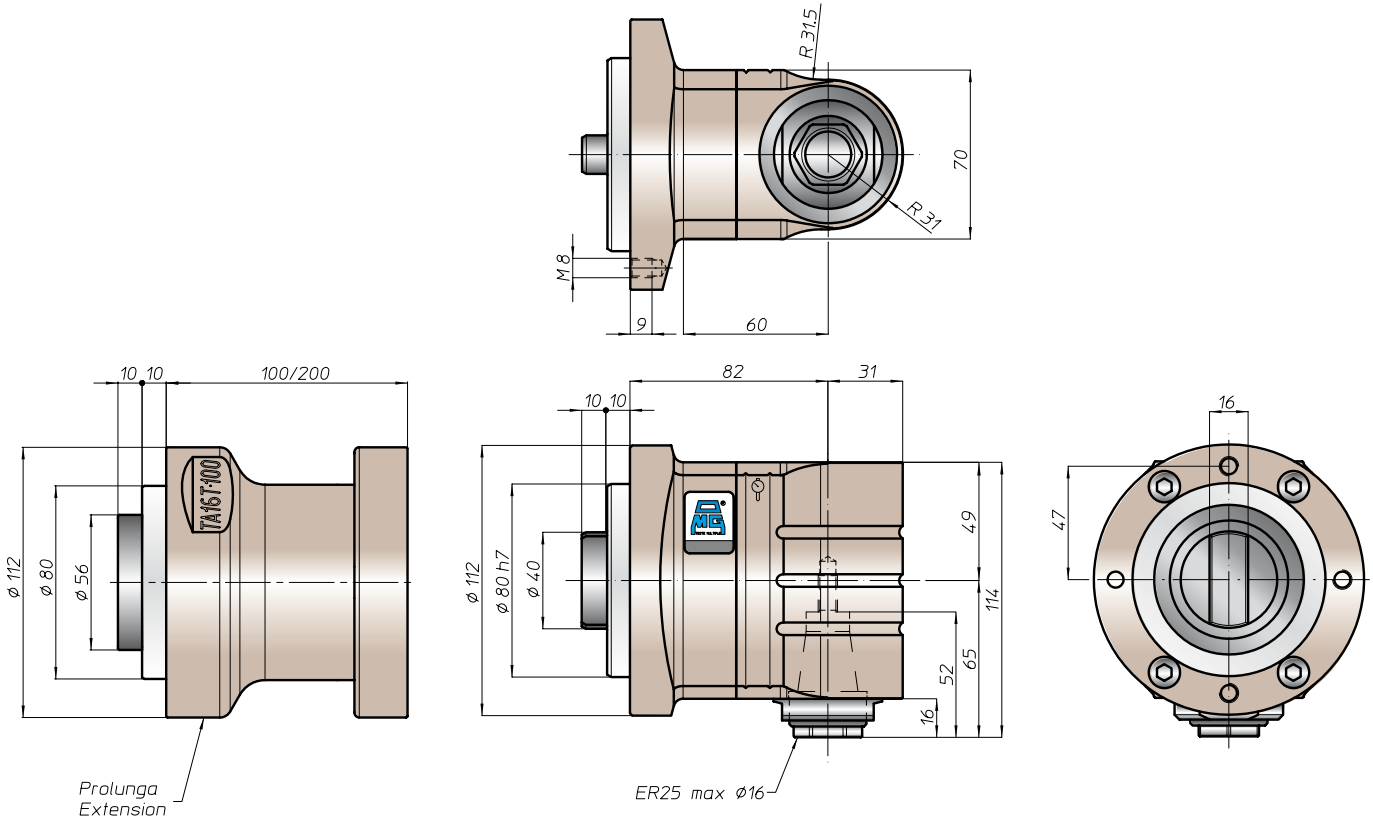

esempio di collegamento - connection example

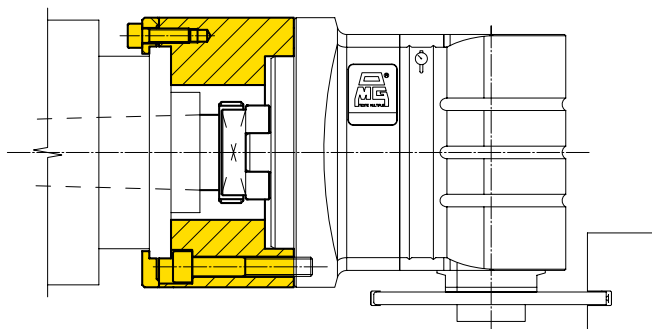

BAH
TA.CP
TA
MO
HT
VH
TSI/TSX
T
MT-TC-TC3
Accessori
Accessories
Appendice tecnica
Technical supplement

TA20.PT



caratteristiche/features



ø 20



M14



1-1



3500

peso/weight



head
7,5 kg



extension

L 100=7,5 kg
L 200=15 kg

rotazione/rotation



input



output

prestazioni/performance

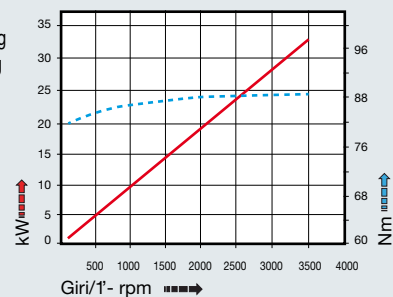

tipi mandrino disponibili / available spindle types

- | | | | | | |
|------------------------------------|---|--|---------------------------------------|--|--|
| 1 DIN6388-ER
ER40 | 2 Albero portafresa
Milling shaft
Ø22-Ø27-Ø32 | 3 Weldon
Whistle-Notch
Ø20-Ø25 | 4 DIN69893-HSK
HSK40 | 5 COROMANT
CAPTO®
C4 | 6 ABS
Licenza KOMET®
ABS40 |
|------------------------------------|---|--|---------------------------------------|--|--|

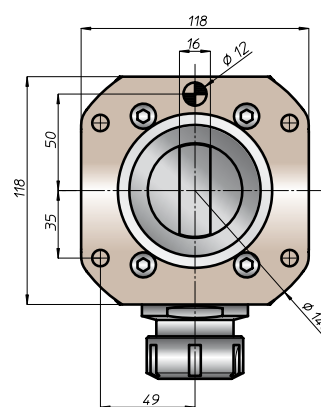
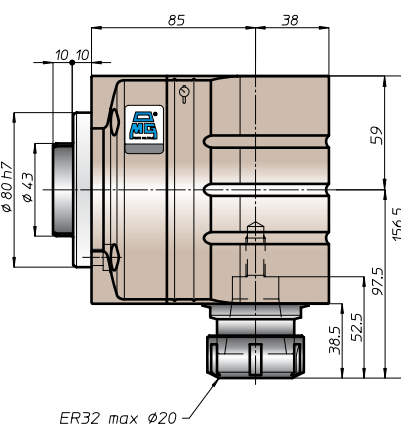
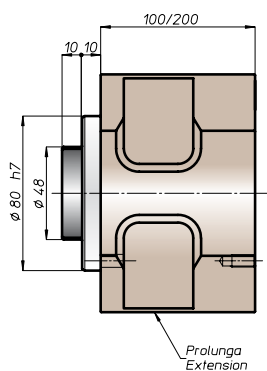
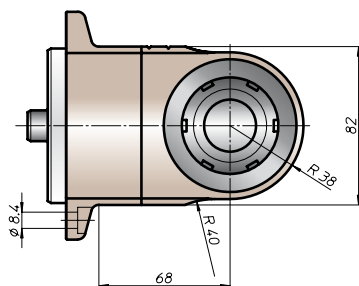

esempio di collegamento - connection example

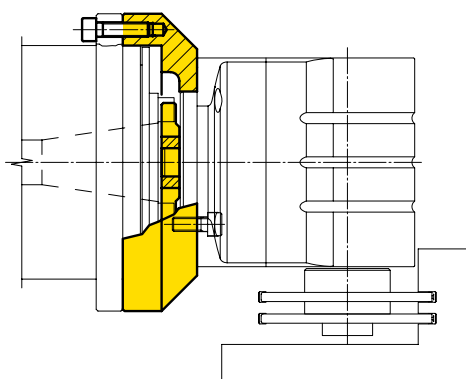

TA20.30.T

caratteristiche/features



peso/weight



rotazione/rotation



prestazioni/performance

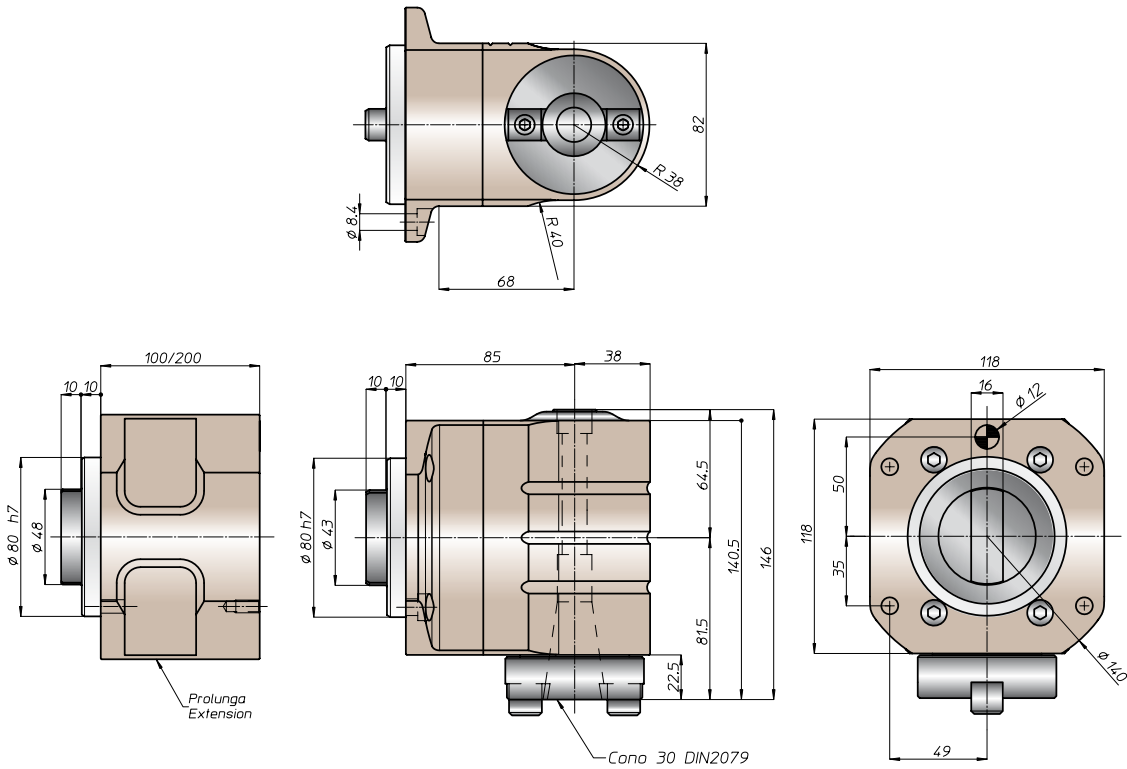
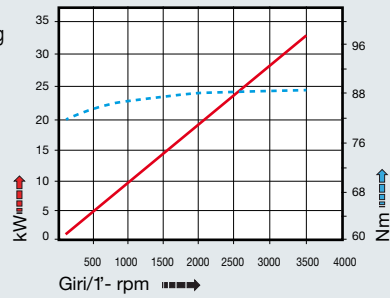

Nota:

- nel mandrino DIN2079 si possono utilizzare coni DIN2080-30, DIN69871-A30, MAS403-BT30

Note:

- on the spindle DIN2079 you can use shank DIN2080-30, DIN69871-A30, MAS403-BT30

esempio di collegamento - connection example

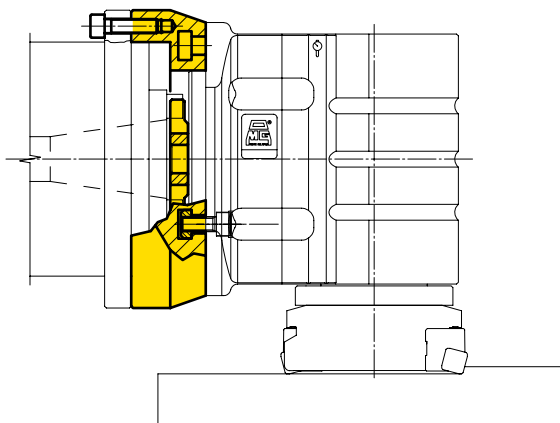

TA26.PT



caratteristiche/features



ø 26



M20



1-1



2500

peso/weight

head



13,5 kg

extension



L 100=12,5 kg
L 200=24 kg

rotazione/rotation



input



output

prestazioni/performance

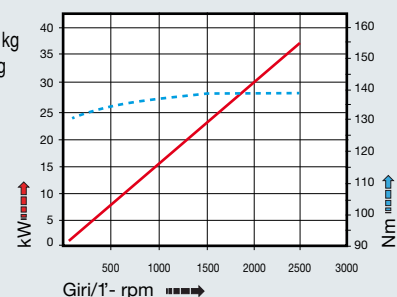

tipi mandrino disponibili / available spindle types

- | | | | | |
|--|---|--------------------------------|-----------------------------------|---|
| 2 Albero portafresa
Milling shaft
Ø16-Ø27-Ø32 | 3 Weldon
Whistle-Notch
Ø32 | 4 DIN69893-HSK
HSK63 | 5 COROMANT
CAPTO®
C4 | 6 ABS
Licenza KOMET®
ABS50 |
|--|---|--------------------------------|-----------------------------------|---|

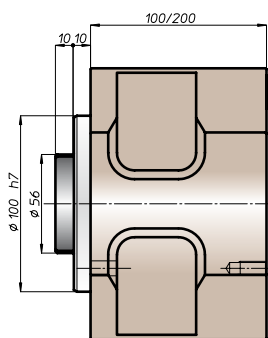
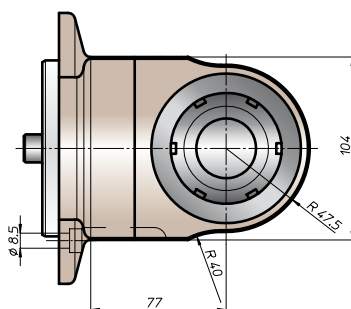

Prolunga
Extension

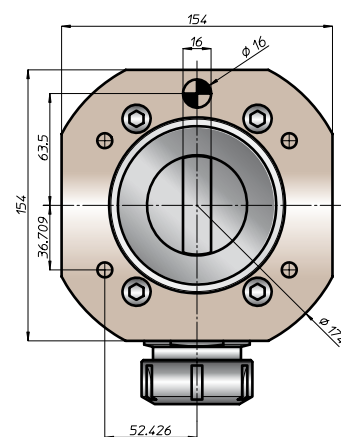
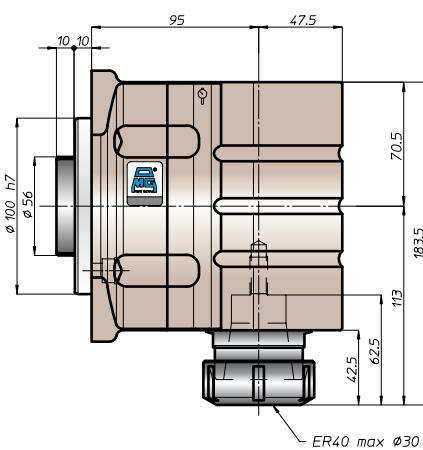

esempio di collegamento - connection example



TA26.40.T

caratteristiche/features



peso/weight



rotazione/rotation



prestazioni/performance

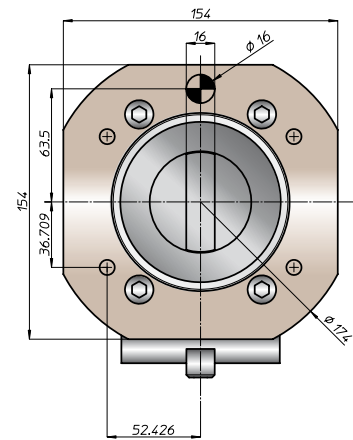
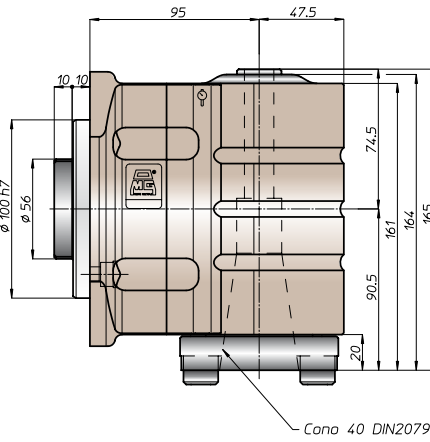
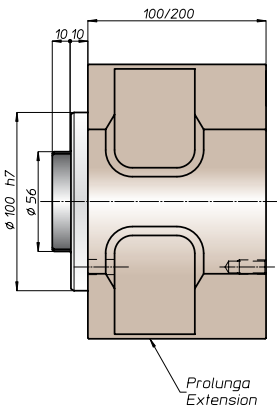
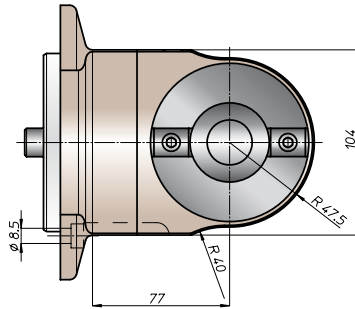
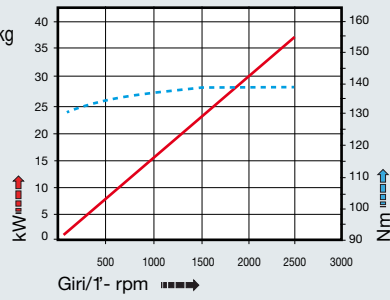

Nota:

- nel mandrino DIN2079 si possono utilizzare coni DIN2080-40, DIN69871-A40, MAS403-BT40

Note:

- on the spindle DIN2079 you can use shank DIN2080-40, DIN69871-A40, MAS403-BT40

esempio di collegamento - connection example



TA40.T



caratteristiche/features



ø 32



M26



1-1



5000

peso/weight

head



33 kg



extension

L 200=26,5 kg

rotazione/rotation



input



output

prestazioni/performance

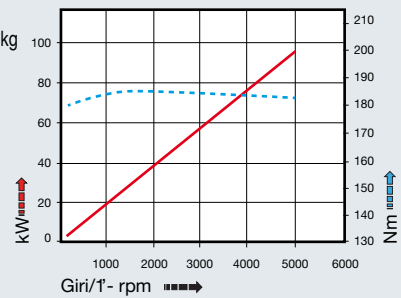

tipi mandrino disponibili / available spindle types

4 DIN69893-HSK
HSK63

5 COROMANT
CAPTO®
C5

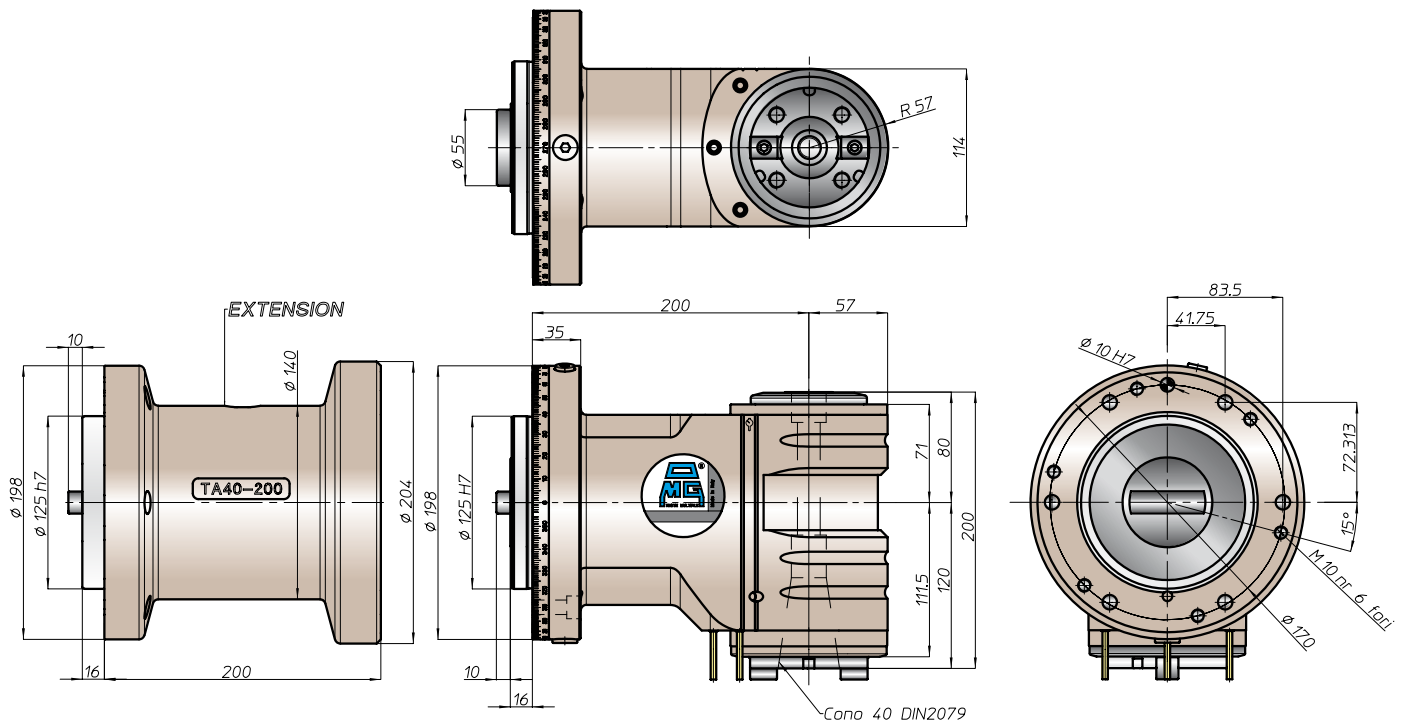

Equipaggiamento standard:

- pressurizzazione mandrino
- n. 3 ugelli orientabili vicino al mandrino
- nel mandrino DIN2079 si possono utilizzare coni DIN2080-40, DIN69871-A40, MAS403-BT40

Standard equipment:

- spindle front pressurization
- nr 3 adjustable nozzle near the spindle
- on the spindle DIN2079 you can use shank DIN2080-40, DIN69871-A40, MAS403-BT40

esempio di collegamento - connection example

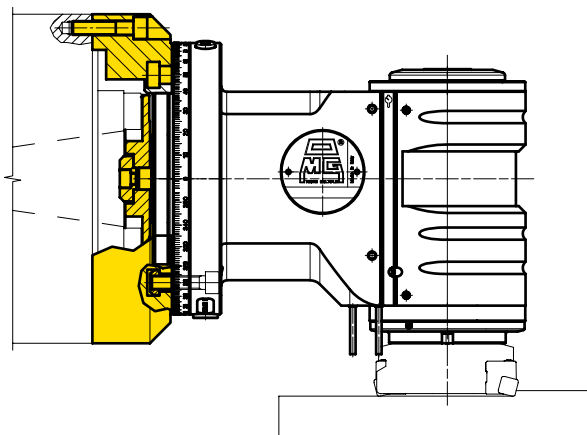

BAH
TA-CP
TA
MO
HT
VH
TSI/TSX
T
MT-TC-TC3
Accessori
Accessories
Appendice tecnica
Technical supplement
3-80



TA40.TD

caratteristiche/features



peso/weight



rotazione/rotation



prestazioni/performances

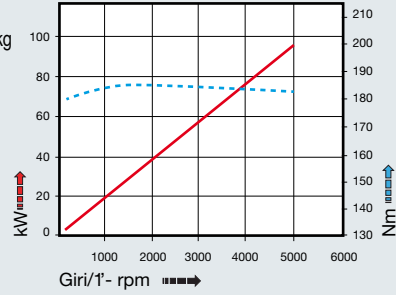

tipi mandrino disponibili / available spindle types

- 4** DIN69893-HSK **HSK63**
- 5** COROMANT CAPTO® **C5**

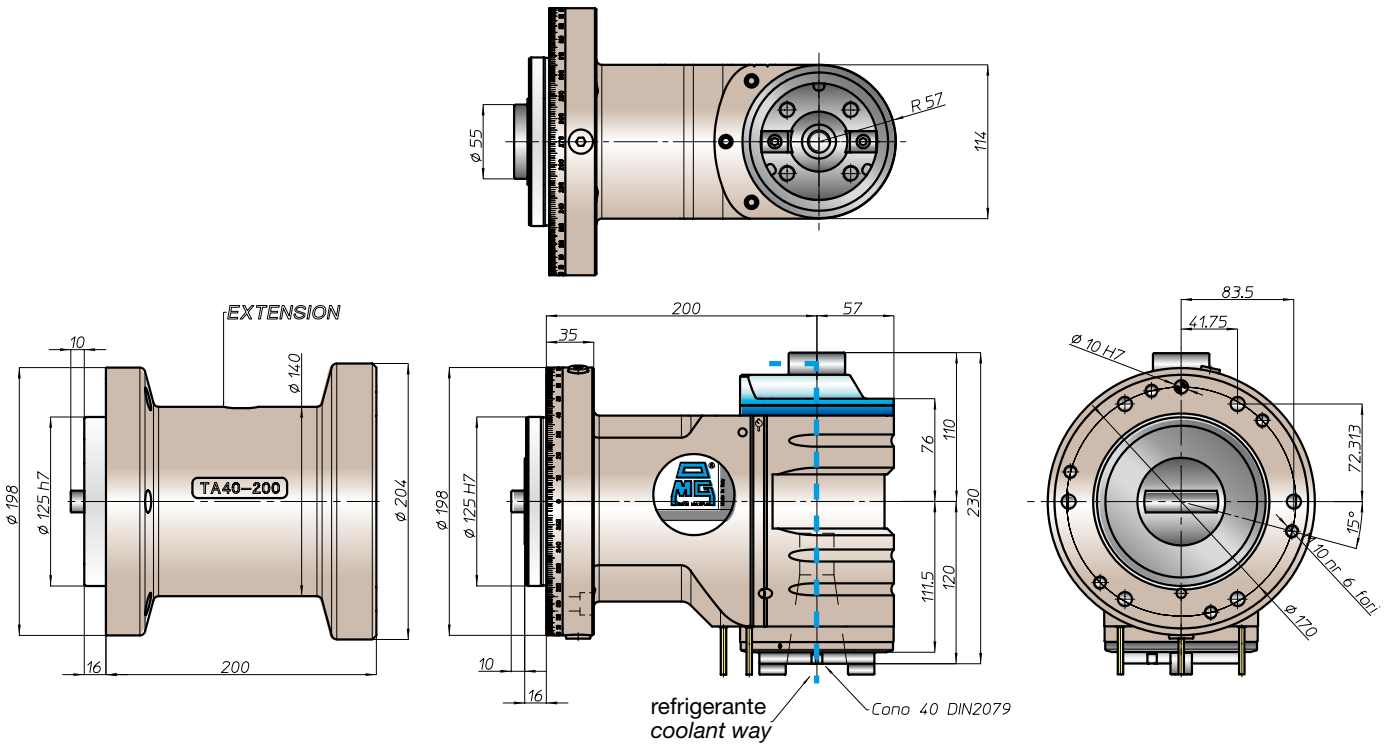

Equipaggiamento standard:

- pressurizzazione mandrino
- n. 3 ugelli orientabili vicino al mandrino
- nel mandrino DIN2079 si possono utilizzare coni DIN2080-40, DIN69871-A40, MAS403-BT40

Standard equipment:

- spindle front pressurization
- nr 3 adjustable nozzle near the spindle
- on the spindle DIN2079 you can use shank DIN2080-40, DIN69871-A40, MAS403-BT40

esempio di collegamento - connection example

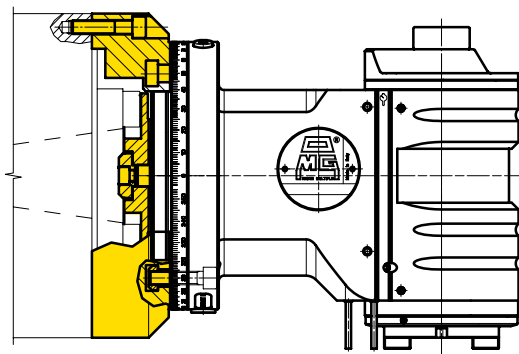

TA50.T



caratteristiche/features



peso/weight



rotazione/rotation



prestazioni/performance

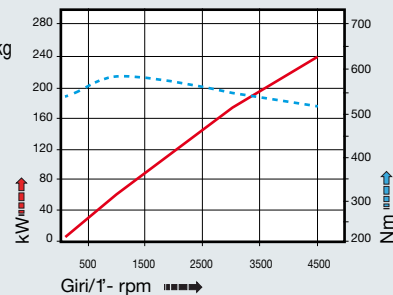

tipi mandrino disponibili / available spindle types

- 4 DIN69893-HSK HSK100
- 5 COROMANT CAPTO® C8

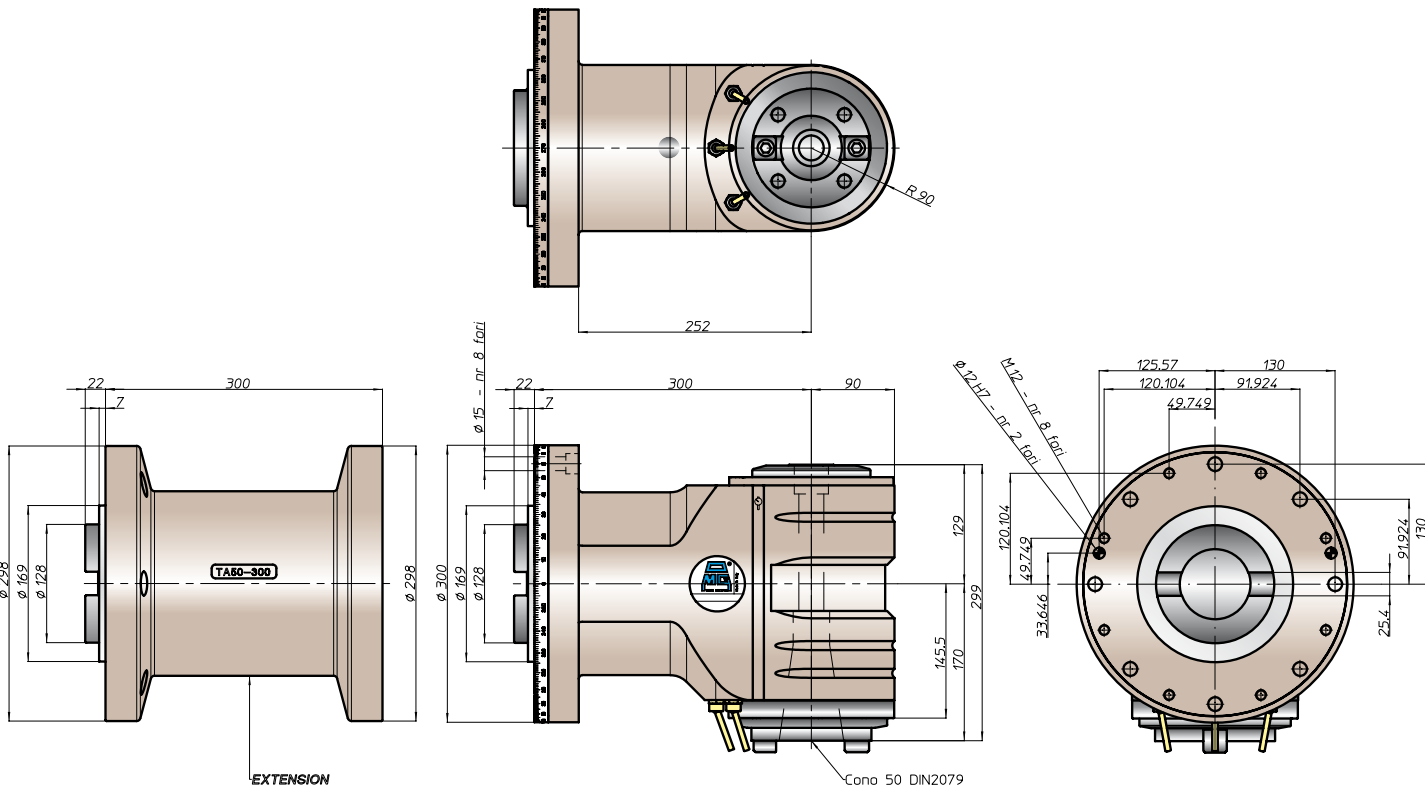

Equipaggiamento standard:

- pressurizzazione mandrino
- n. 3 ugelli orientabili vicino al mandrino
- nel mandrino DIN2079 si possono utilizzare coni DIN2080-50, DIN69871-A50, MAS403-BT50

Standard equipment:

- spindle front pressurization
- nr 3 adjustable nozzle near the spindle
- on the spindle DIN2079 you can use shank DIN2080-50, DIN69871-A50, MAS403-BT50

applicazione con asse C-310 manuale - example with manual C axis C-310

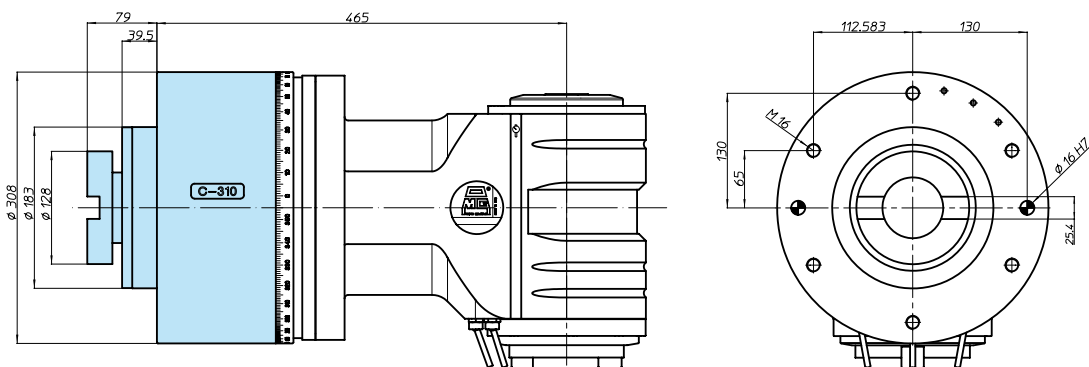

BAH
TA-CP
TA
MO
HT
VH
TSI/TSX
T
MT-TC-TC3
Accessori
Accessories
Appendice tecnica
Technical supplement



TA50.TD

caratteristiche/features



ϕ 45 M36 1-1
 2500 RPM 50 bar
 4000

peso/weight

head  extension  L 300=110 kg
 112 kg

rotazione/rotation

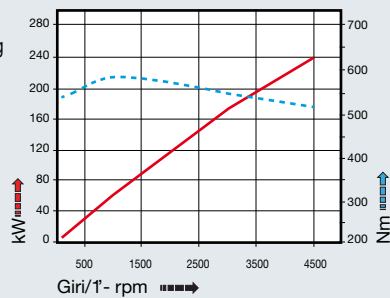

 input output

prestazioni/performance

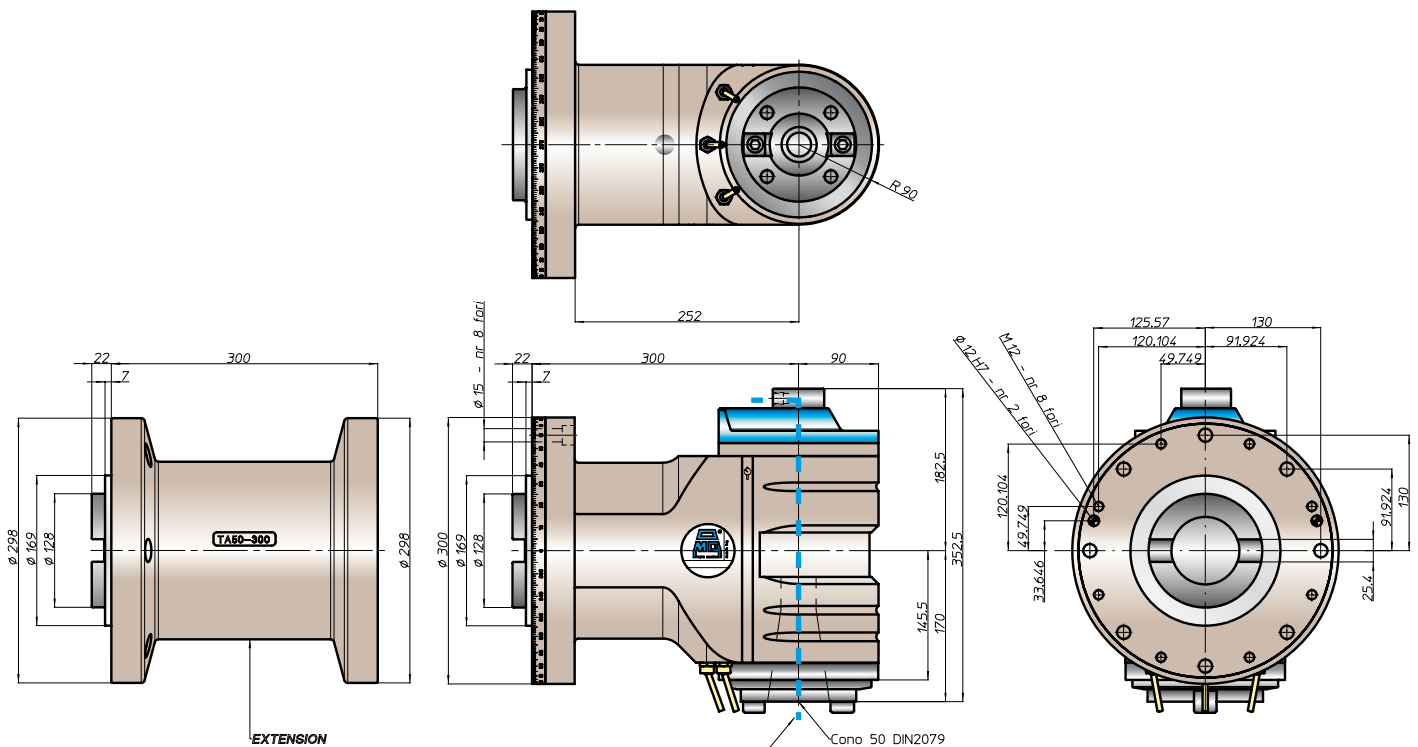

tipi mandrino disponibili / available spindle types

4 DIN69893-HSK 5 COROMANT CAPTO®
HSK100 **C8**



Equipaggiamento standard:

- pressurizzazione mandrino
- n. 3 ugelli orientabili vicino al mandrino
- nel mandrino DIN2079 si possono utilizzare coni DIN69871-A50, MAS403-BT50

refrigerante
coolant way

Standard equipment:

- spindle front pressurization
- nr 3 adjustable nozzle near the spindle
- on the spindle DIN2079 you can use shank DIN69871-A50, MAS403-BT50

esempio di collegamento - connection example

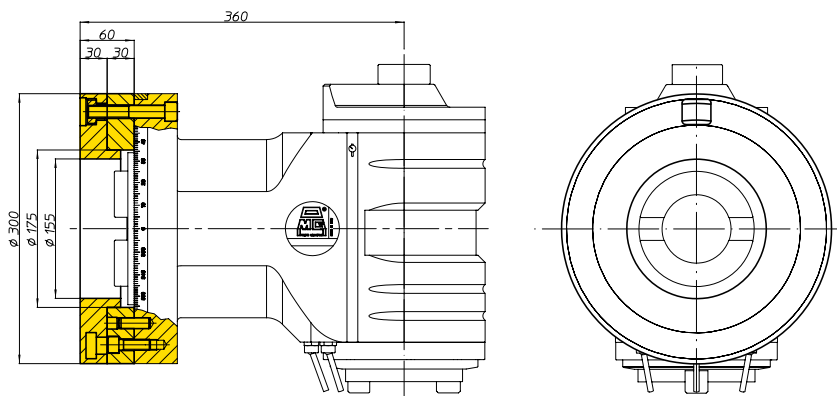

TA..T Extended Gallery



BAH

TA-CP

TA

MO

HT

VH

TSI/TSX

T

MT-TC-TC3

Accessori
Accessories

Appendice tecnica
Technical supplement



TA..T Extended Gallery



BAH

TA.CP

TA

MO

HT

VH

TSI/TSX

T

MT-TC-TC3

Accessori
Accessories

Appendice tecnica
Technical supplement



testa ad angolo - angle head

TA13.PVDI



caratteristiche/features



ø 13



M10



1-1



8000

peso/weight



4,5 kg

rotazione/rotation



input



output

prestazioni/performance

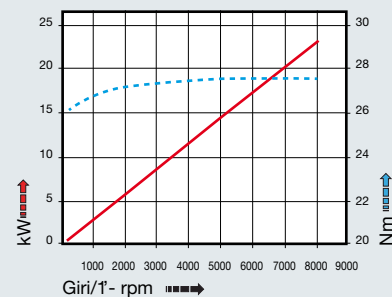

tipi mandrino disponibili / available spindle types

1 DIN6388-ER
ER25

2 Albero portafresa
Milling shaft
Ø16-Ø22

3 Weldon
Whistle-Notch
Ø16

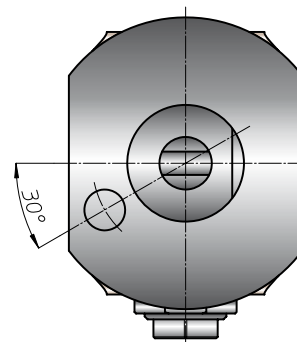
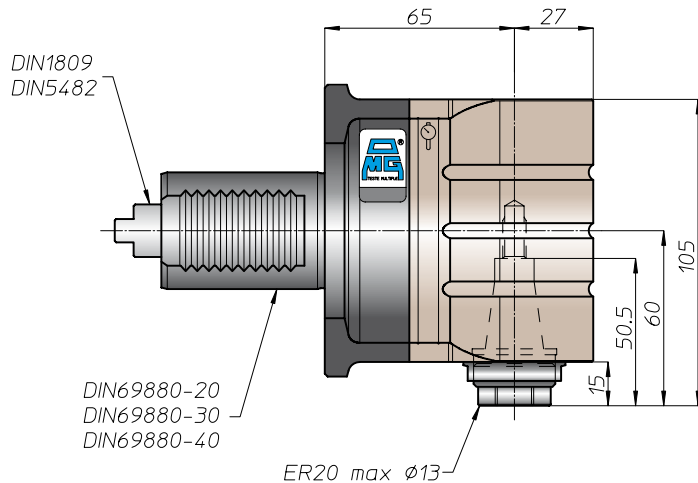
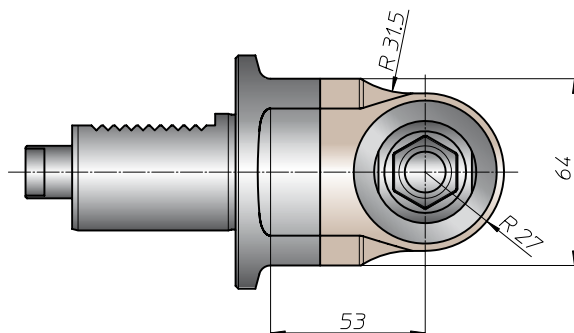

soluzioni speciali - special solutions



BAH

TA-CP

TA

MO

HT

VH

TSI/TSX

T

MT-TC-TC3

Accessori
Accessories

Appendice tecnica
Technical supplement



TA16.PVDI

caratteristiche/features

-  ø 16
-  M12
-  1-1
-  5000

peso/weight



6,5 kg

rotazione/rotation



input



output

prestazioni/performance

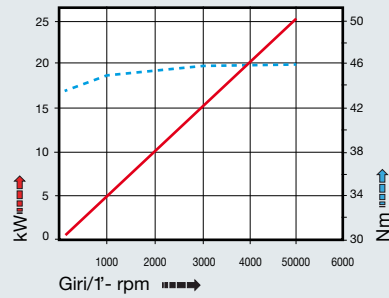

tipi mandrino disponibili / available spindle types

- | | | | | | |
|------------------------------------|---|--|---------------------------------------|--|--|
| 1 DIN6388-ER
ER32 | 2 Albero portafrese
Milling shaft
Ø16-Ø27-Ø32 | 3 Weldon
Whistle-Notch
Ø20 | 4 DIN69893-HSK
HSK32 | 5 COROMANT
CAPTO®
C3 | 6 ABS
Licenza KOMET®
ABS32 |
|------------------------------------|---|--|---------------------------------------|--|--|

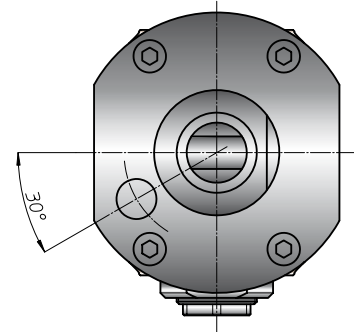
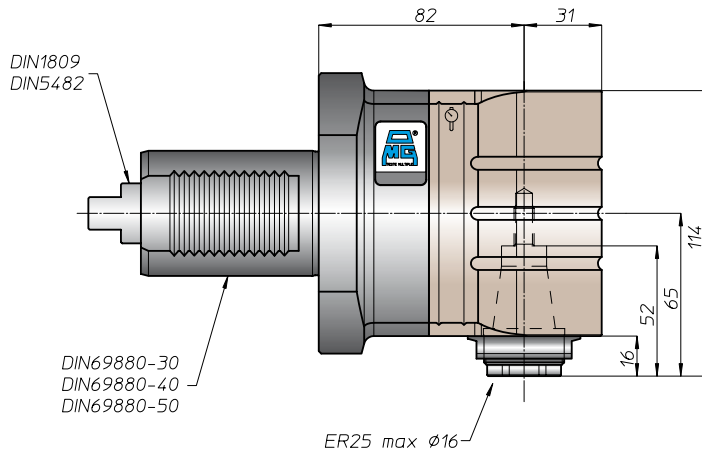
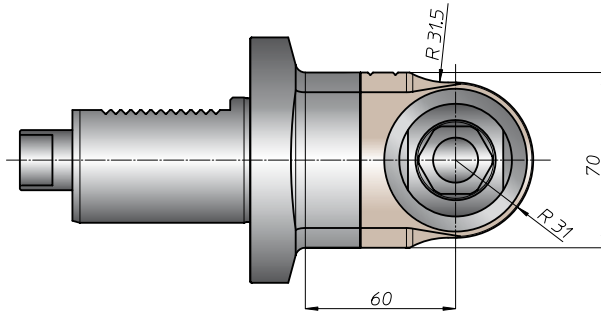

soluzioni speciali - special solutions



BAH
TA.CP
TA
MO
HT
VH
TSI/TSX
T
MT-TC-TC3
Accessori
Accessories
Appendice tecnica
Technical supplement

testa ad angolo - angle head

TAV10.PVDI



caratteristiche/features



ø 10



M8



1-1



4000

peso/weight



3,5 kg

rotazione/rotation



input



output

prestazioni/performance

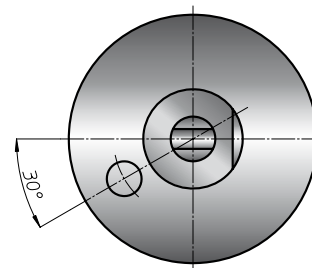
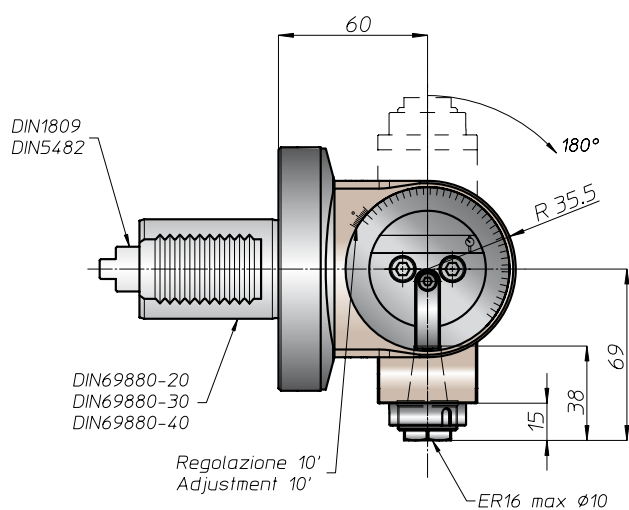
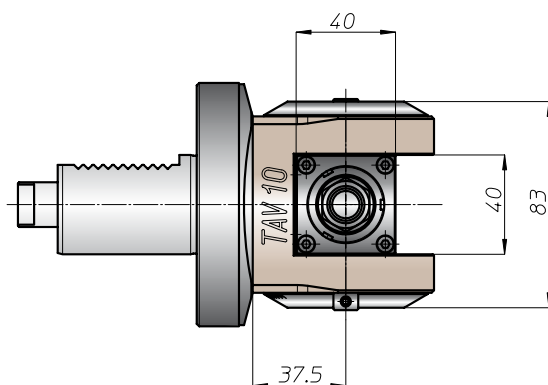
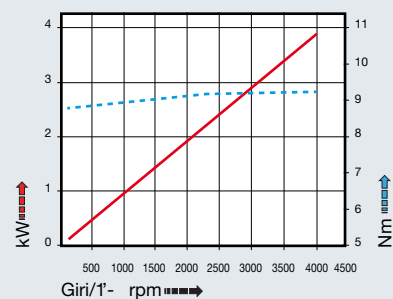

soluzioni speciali - special solutions

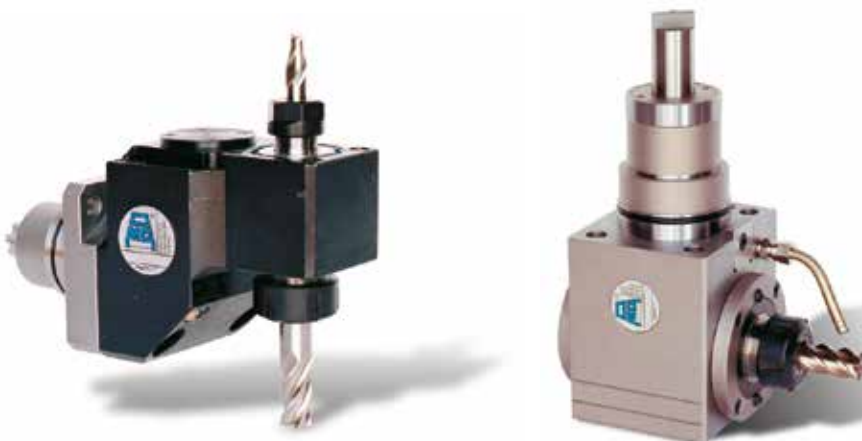

BAH

TA-CP

TA

MO

HT

VH

TSI/TSX

T

MT-TC-TC3

Accessori
Accessories

Appendice tecnica
Technical supplement

3-88



TAV13.PVDI

caratteristiche/features



peso/weight



rotazione/rotation

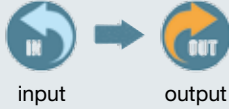

prestazioni/performance

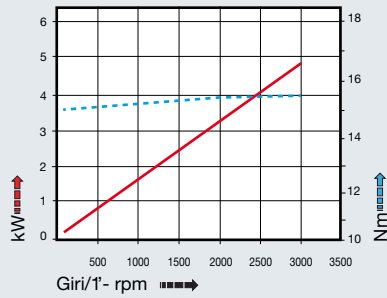

tipi mandrino disponibili / available spindle types

- 1** DIN6388-ER **ER25**
- 3** Weldon Whistle-Notch **Ø16**

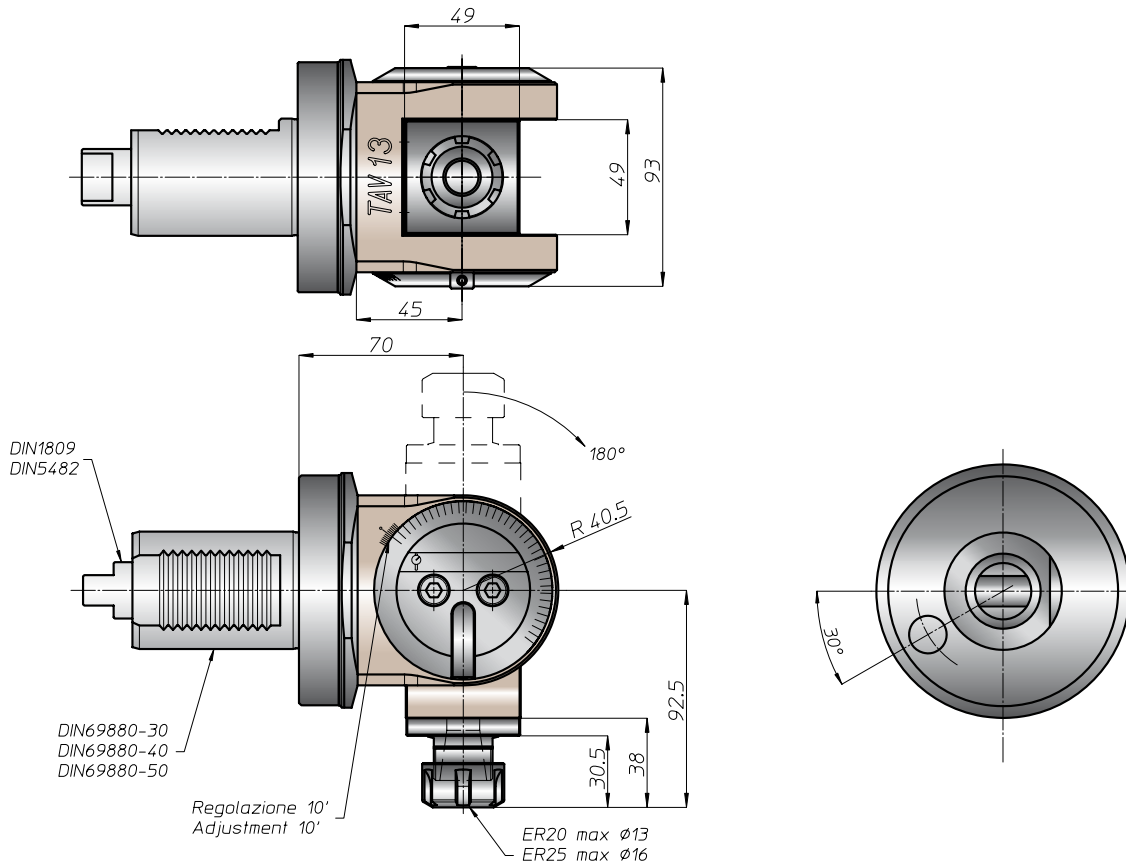

soluzioni speciali - special solutions



BAH
TA.CP
TA
MO
HT
VH
TSI/TSX
T
MT-TC-TC3
Accessori
Accessories
Appendice tecnica
Technical supplement





Antirotante Torque arm

Teste ad angolo con interasse H=65
Angle heads with centre distance H=65

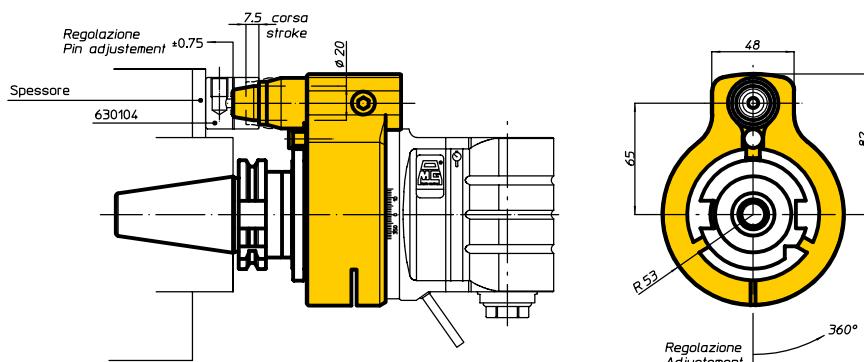

Il gruppo antirotante ricopre una funzione di fondamentale importanza nella qualità di lavorazione della testa ad angolo. Per questo motivo i tecnici della OMG hanno studiato e messo a punto un antirotante di nuova concezione i cui punti salienti sono:

- Il perno conico
- La registrazione assiale del perno
- Adduzione del liquido passante per il corpo testa

Il perno conico e la propria registrazione assiale di mm 1.5 permettono una maggiore rigidità del sistema antirotante rispetto ai tradizionali, dotati di perni di Ø18 mm perché si eliminano i giochi con conseguente miglioramento della rigidità sia angolare che assiale.

L'adduzione del liquido passante per il corpo testa, la cui uscita avviene tramite un ugello direzionabile, offre il vantaggio di non avere tubi "volanti" che possono muoversi durante le lavorazioni.

Teste ad angolo con interasse H=80
Angle heads with centre distance H=80

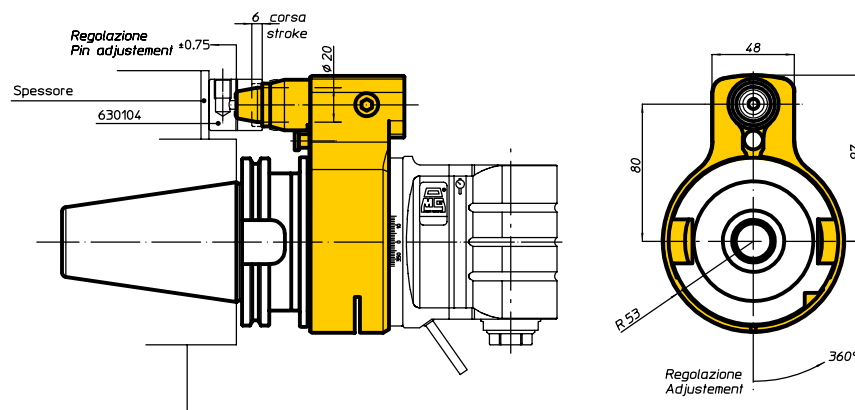

Teste ad angolo con interasse H=110
Angle heads with centre distance H=110

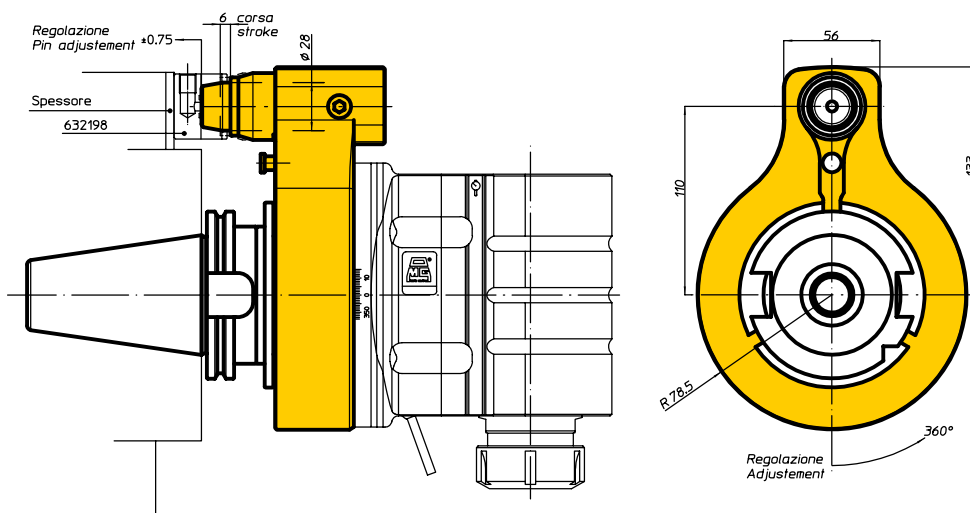

Quando possibile, nella Vostra applicazione, posizionate il perno conico dalla parte opposta al mandrino della testa ad angolo.



Stop-block

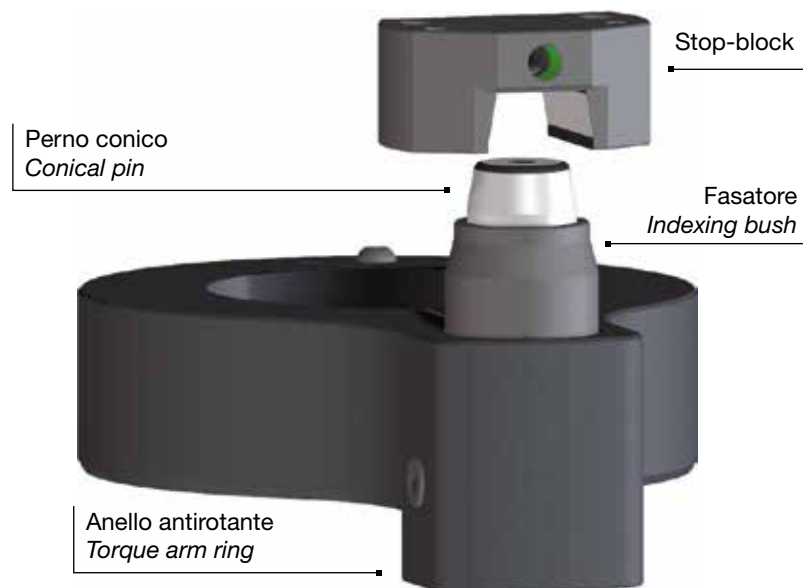

The torque arm system is crucial as far as angle-head machining quality is concerned. For this reason OMG technicians have designed and developed a new system with the following characteristics:

- conical pin
- axial pin adjustment
- coolant through the head body

The conical pin and its 1.5 mm axial adjustment ensure upgraded antirotation system strength compared to traditional systems, featuring $\varnothing 18$ mm pin, because play is eliminated, thereby improving both angular and axial strength.

By the pin the coolant through the head, thanks to an adjustable nozzle, the added advantage is achieved of eliminating "free" pipes that could move during machining operations.

Double Stop-block (cod. 632199)

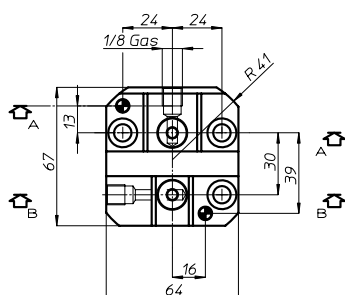
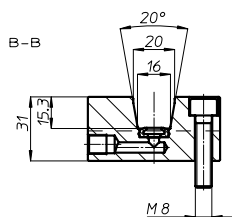
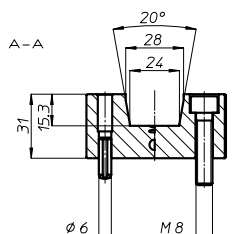

Stop-block (cod. 632198)

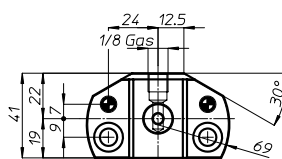
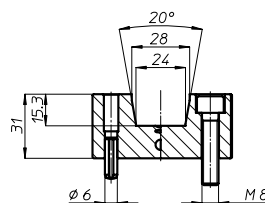

Stop-block (cod. 630104)

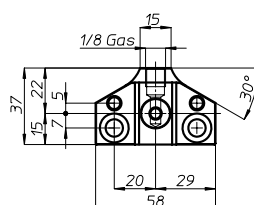
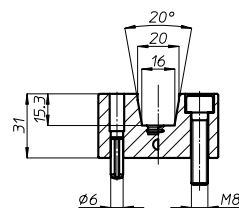

Position the conical pin on the opposite side of the angle head spindle when possible in your application.





Il gruppo antirotante **TriBlock** ricopre una funzione di fondamentale importanza quando alla testa ad angolo è richiesto di:

- eseguire una lavorazione più pesante
- essere più lunga dello standard
- finitura superficiale eccellente

Il **TriBlock** è dotato di tre punti di appoggio di cui uno è lo standard come nei precedenti e due supplementari da registrare tramite un rasamento. Questi tre punti, allargando l'appoggio di base della testa ad angolo, consentono di ottenere una rigidità superiore allo standard. Quando poi si richiede alla testa di essere immagazzinata su di un supporto esterno al magazzino standard, ecco che il **TriBlock** utilizza i propri tre punti per posizionare la testa.

Antirotante/Torque arm

TriBlock

Teste ad angolo con interasse H=65
Angle heads with centre distance H=65

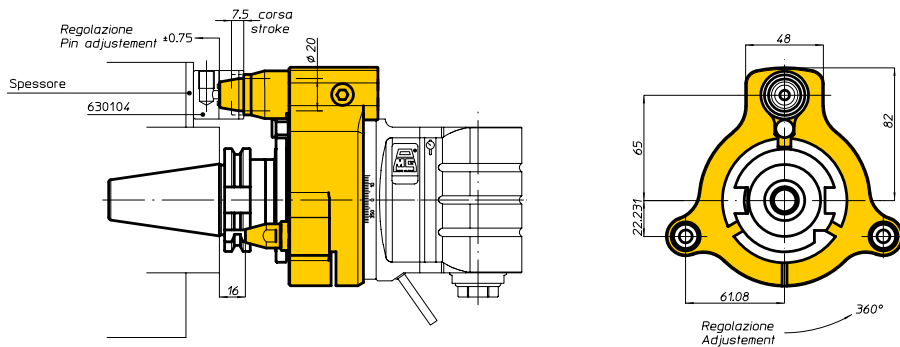

Teste ad angolo con interasse H=80
Angle heads with centre distance H=80

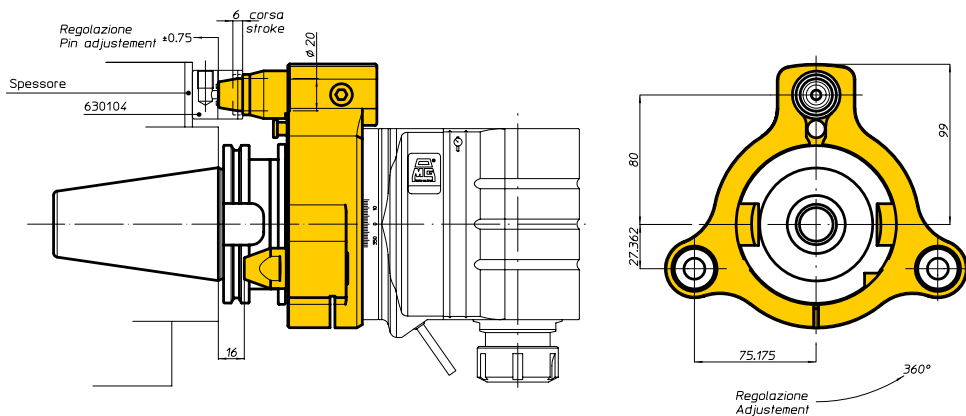

Teste ad angolo con interasse H=110
Angle heads with centre distance H=110

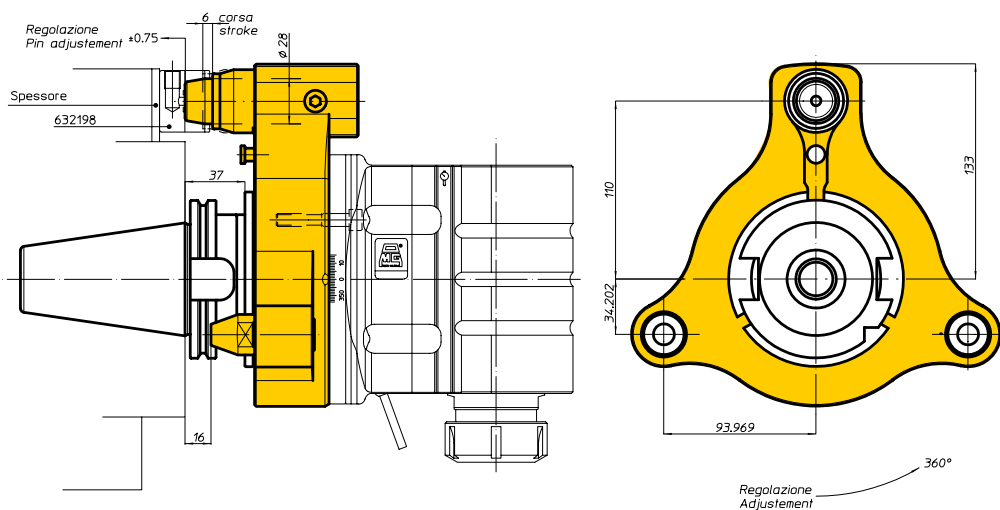

Antirotante/Torque arm

TriBlock

Sul mandrino macchina
On spindle machine

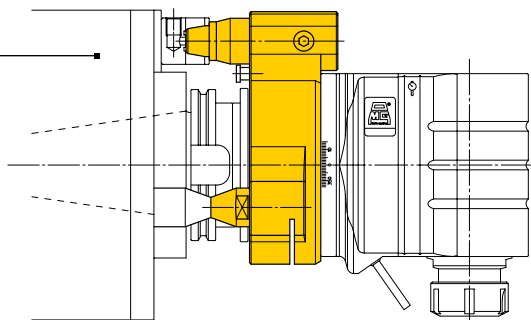

TFS 19907
Testa ad angolo per fresatura
componente motore a reazione.
Peso Kg 45,5
Milling angle head for jet engine.
Weight Kg 45,5

TFS 39195

Testa bимandrino di fresatura n° 2 frese
Ø 100 peso Kg 33
Twin milling head, nr. 2 milling cutter
Ø 100 weight Kg 33

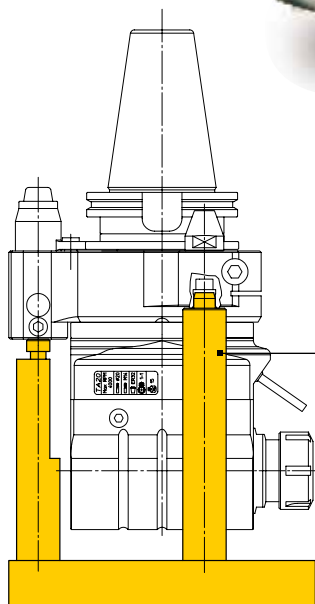
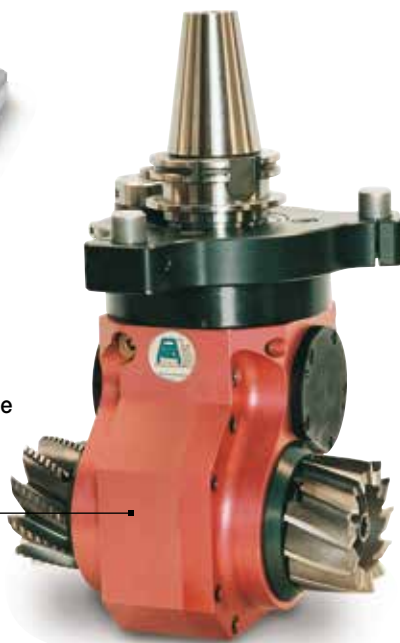

Sul supporto da tavola
On rack table



The **TriBlock** system is of crucial importance when it comes to:

- doing difficult jobs
- having a head that is longer than standard
- achieving an excellent surface finish

The **TriBlock** system features three supporting points, one of which is standard, as in the previous version, plus two additional ones that need adjusting by means of a spacer. These three points, by extending the angle-head supporting base, provide above-average standards of strength.

When the head has to be stored on a rack table outside the standard magazine, the **TriBlock** system uses the three points to storage the angle heads.

BAH

TA.CP

TA

MO

HT

VH

TSI/TSX

T

MT-TC-TC3

Accessori
Accessories

Appendice tecnica
Technical supplement

Antirotante/Torque arm

QuadBlock 



Il sistema antirotante **QuadBlock** è un sistema all'avanguardia per equipaggiare Teste ad Angolo dove si richiede alta asportazione e alta rigidità dell'insieme "testa ad angolo-macchina". Utilizzabile nel montaggio manuale, esso consiste in un anello antirotante completo di quattro perni di contrasto suddivisi equamente sui 360°. Tale disposizione consente di poter ruotare la Testa ad Angolo in automatico con un semplice movimento della macchina, se questa ne ha le capacità. Il vantaggio di poter lavorare quattro facce del pezzo senza sostituire la Testa ad Angolo si concretizza con la riduzione dei costi previsti per gli utensili.

L'evoluzione del sistema **QuadBlock** per le macchine con cambio automatico, consente di utilizzare la Testa ad Angolo come un prolungamento del mandrino macchina ruotato dei gradi richiesti dal cliente. È possibile inoltre sostituire il portautensile in automatico ed ampliare infinitamente la versatilità della macchina utensile avendo a disposizione quei servizi normalmente presenti sul mandrino macchina:

- Aria pulizia del portautensile
- Liquido refrigerante centro utensile alta pressione
- Liquido refrigerante esterno utensile
- Liquido bloccaggio-sbloccaggio utensile
- Controllo presenza utensile

Tutto ciò per consentire l'utilizzo di portautensili tipo Capto, HSK, DIN69871. Mettiamo a disposizione il nostro ufficio tecnico e la nostra esperienza per personalizzare al meglio il Vostro sistema.

TAS13609

Fresatura su corpo in fusione di ghisa. Peso kg 36.
Milling on cast iron pump's body. Weight 36 kg.



TAS13209

Lavorazione di finitura interna culle motore idraulico. Peso kg 36.
Internal finishing work for hydraulic motor's body. Weight 21 kg.



TAS16209

Linee di servizio per il mandrino HSK63F con cambio automatico dell'utensile, sensore presenza utensile in radiofrequenza. Peso kg 28.
Utility line for HSK63F spindle with automatic tool change, radio-frequency switch to verify tool presence. Weight 28 kg.



Antirotante/Torque arm

QuadBlock 

TAS24408

Lavorazione di fresatura interna
corpo pinza freno in ghisa.
Peso Kg 28.
*Triblock with automatic locking.
Cast iron brake housing internal
milling work. Weight 28 kg.*

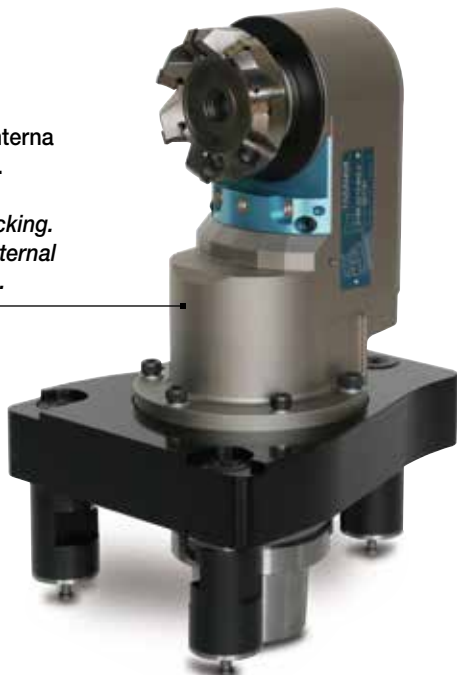

TA12907

Lavorazione di fresatura generica
struttura elettrosaldada di acciaio.
Peso Kg 48.
*Special Quadblock with automatic
locking. General milling work on
electro-welded steel structure.
Weight 48 kg.*

TAS08606

Servizi per mandrino CAPTO C4 con
cambio automatico dell'utensile.
Peso kg 36.
*Spindle with utility line for CAPTO C4
with automatic tool change.
Weight kg 36.*



The **QuadBlock** torque arm is a forefront system to equip Angle Heads which are requested with a high removal machining capacity and with extremely high rigidity in coupling with the machine tool. It can be used with a manual tool change and is made by a torque arm ring complete with four counterposed pins with same distance each other on the 360°. Such a layout allows an automatic rotation of the Angle Head with a simple movement of the machine if featured to do it. The possibility of machining four faces of the piece without replacing the Angle Head is giving the advantage of reducing costs of tools equipment.

The evolution of the **QuadBlock** system on automatic tool change machines allows to use the Angle Head like an extension of the machine spindle with the degree rotations required by the customer. It is also possible to automatically change the tool holder and to infinitely widen the versatility of the machine tool getting those utilities normally available on the machine spindle:

- tool-holder cleaning air
- through-tool high pressure coolant
- side-tool coolant
- tool locking-unlocking liquid
- tool presence control

All these to allow using tool-holders like Capto, HSK, DIN69871. Our R&D department is at your disposal with his experience to customize your system at its best.

BAH

TA.CP

TA

MO

HT

VH

TSI/TSX

T

MT-TC-TC3

Accessori
Accessories

Appendice tecnica
Technical supplement



Teste ad angolo speciali

Special angle heads

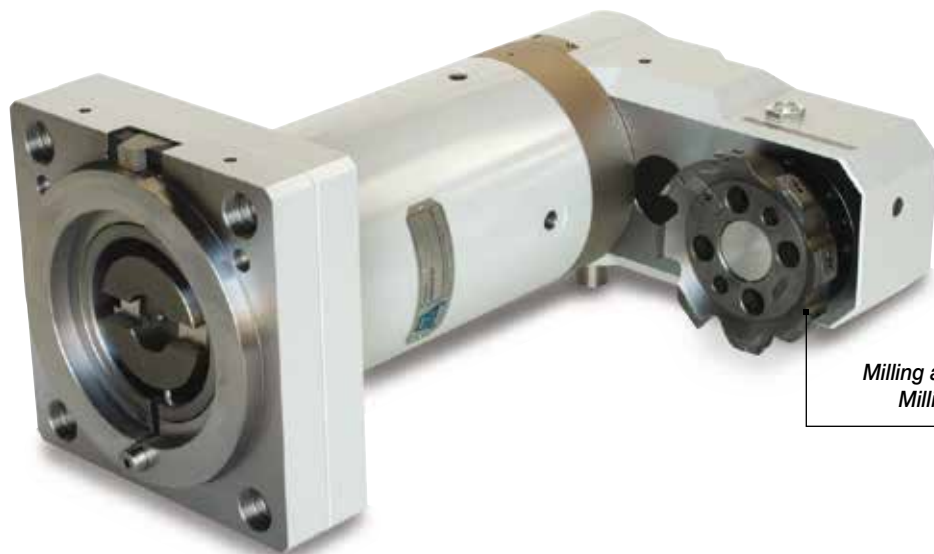

TFS 41304

Testa ad angolo di fresatura con mandrino ribaltato.
Fresa Ø 200. Peso Kg 327,5.
*Milling angle head with reverse spindle.
Milling tool Ø 200. Weight Kg 327,5.*



TFS 05303

Testa ad angolo di fresatura con fresa diam. 7 peso Kg 8
Milling angle head with milling cutter diam. 7 weight Kg 8



TFS 23301

Testa ad angolo di foratura a tre mandrini peso kg 5,9
Drilling angle head with three spindles weight kg 5,9



TFS 39998

Testa ad angolo universale. Presa utensili ISO50, peso kg 580
Angle head with tool shank ISO50, weight kg 580



TAS 15505

Testa ad angolo di foratura e fresatura, attacco utensile CAPTO C4 automatico. Peso Kg 130.
Drilling and milling angle head, automatic tools changer CAPTO C4. Weight Kg 130.



Teste ad angolo speciali

Special angle heads



TFS 36699

Testa ad angolo bimandrino
registrabile, peso kg 29
*Adjustable twin angle head,
weight kg 29*

TFS 34004

Testa ad angolo di foratura
a 3 mandrini a 120°.
Peso Kg 18.
*Drilling angle head, n 3
spindles at 120°.
Weight Kg 18.*



TA 09603

Testa ad angolo di alesatura con
utensile Ø 160 peso Kg 77
*Boring angle head with tools
Ø 160 weight Kg 77*

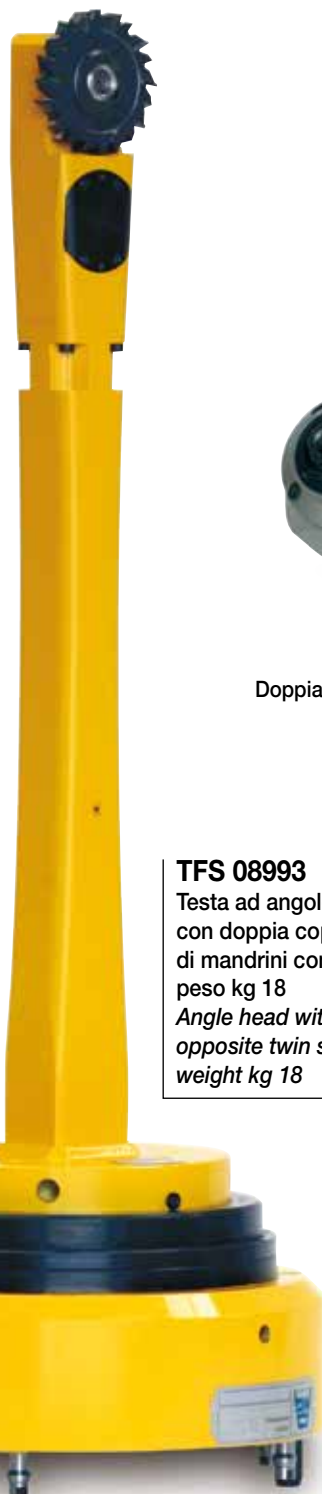

TFS 08993

Testa ad angolo speciale
con doppia coppia
di mandrini contrapposti
peso kg 18
*Angle head with two
opposite twin spindles
weight kg 18*



TAF 37503

Doppia testa ad angolo di foratura.
Twin drilling angle head.

TFS 06003

Testa ad angolo di fresatura con
fresa Ø 110 peso Kg 210
*Milling angle head with milling
cutter Ø 110 weight Kg 210*



Teste ad angolo speciali

Special angle heads



TAS 33206

Testa bimandrino di fresatura
per frese Ø 160 peso kg 63
*Twin milling head with
milling cutter Ø 160 weight kg 63*



TFS 21701

Testa di fresatura a due mandrini
paralleli, peso kg 14
*Milling angle head with two parallel
spindles, weight kg 14*

TFS 34495

Testa bimandrino di fresatura n. 2 frese Ø 130
peso kg 290
*Twin milling head, nr. 2 milling cutter Ø 130
weight kg 290*

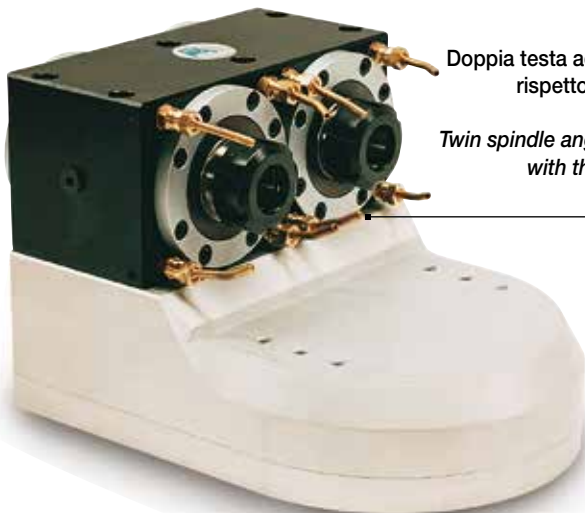

TFS 16696

Doppia testa ad angolo disassata
rispetto all'asse macchina
peso kg 24
*Twin spindle angle head not in line
with the machine spindle
weight kg 24*



TFS 36994

Testa bimandrino di fresatura
n. 2 frese Ø 60, peso kg 15,5
*Twin milling head, nr. 2 milling
cutter Ø 60, weight kg 15,5*



Teste ad angolo speciali

Special angle heads



TFS 12101
 Testa di fresatura con cono ISO30
 peso kg 16
*Milling angle head with ISO30
 weight kg 16*



TFS 13094
 Testa ad angolo disassata
 rispetto all'asse macchina
 peso kg 17
*Angle head not in line
 with the machine spindle
 weight kg 17*

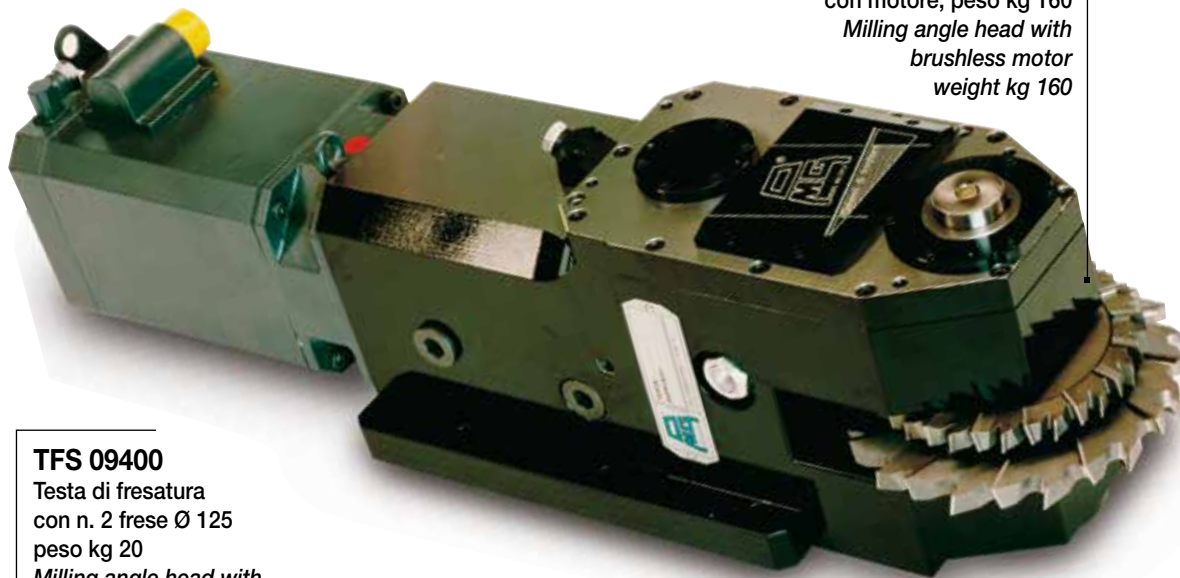

TFS 50900
 Testa di fresatura
 con motore, peso kg 160
*Milling angle head with
 brushless motor
 weight kg 160*

TFS 09400
 Testa di fresatura
 con n. 2 frese Ø 125
 peso kg 20
*Milling angle head with
 nr. 2 milling cutter Ø 125
 weight kg 20*



TFS 24196
 Testa ad angolo bimandrino per
 fresatura su scatola del cambio
 peso kg 70
*Twin milling spindle angle head
 on gear box weight kg 70*



Teste ad angolo speciali

Special angle heads

TAS 41504

Testa ad angolo mandrino di fresatura. Peso Kg 338.
Twin milling angle head. Weight Kg 338.



TFS 35698

Testa ad angolo di fresatura con fresa Ø 100 peso Kg34
Milling angle head, with milling cutter Ø 100 weight Kg 34



TFS 12005

Testa ad angolo disassata per fresature Ø 150.
Peso Kg 48.
Shift spindle angle head, milling tools Ø 150. Weight Kg 48.

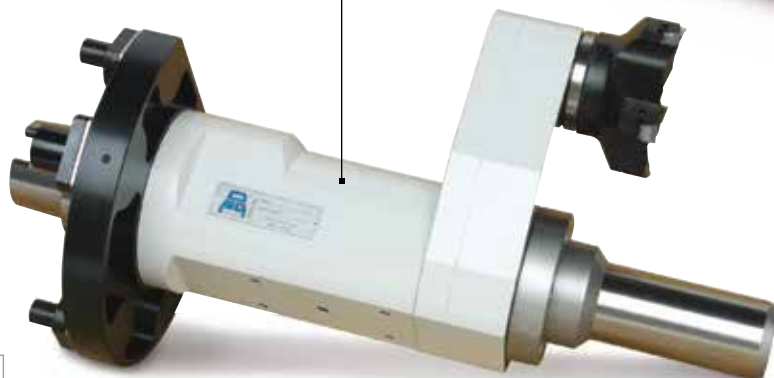

TFS 28603

Testa di fresatura con n. 4 frese a disco Ø 125. Peso Kg 218.
Milling head, nr. 4 milling disc cutter Ø 125. Weight Kg 218.



Teste ad angolo speciali

Special angle heads



TFS 33303
 Testa ad angolo disassata
 per foratura. Peso Kg 9,4.
*Angle head with shift
 drilling spindle.
 Weight Kg 9,4.*



TFS 12095
 Testa ad angolo di
 foratura peso kg 5
*Drilling angle head
 weight Kg 5*



TAS 30505
 Testa ad angolo di foratura
 HSK100 entrata e uscita.
 Peso Kg 50.
*Drilling angle head, HSK 100
 input-output. Weight Kg 50*

TFS 33503
 Testa ad angolo di lucida-
 tura con doppia rotazione,
 sia corpo che utensile.
 Peso kg 6,5.
*Polish angle head with
 duble rotation: body and
 tools. Weight Kg 6,5.*



TFS 13198
 Testa ad angolo
 disassata per foratura
 peso kg 5
*Angle head with
 shift spindle
 weight kg 5*



Teste ad angolo speciali

Special angle heads



TAS 13806

Testa biambrino Capto C5
manuale, peso kg 33
*Twin angle head with Capto C5
manual clamping tool
weight kg 33*



TAS 39806

Testa di foratura a due mandrini
con refrigerante attraverso il
centro utensile a 50 Bar
peso kg 21
*Twin drilling angle head with
coolant through the centre tool
at 50 Bar, weight kg 21*

TFS 39997
Testa ad angolo speciale
biambrino per foratura e
maschiatura peso kg 16
*Twin angle head for
drilling and tapping
weight kg 16*

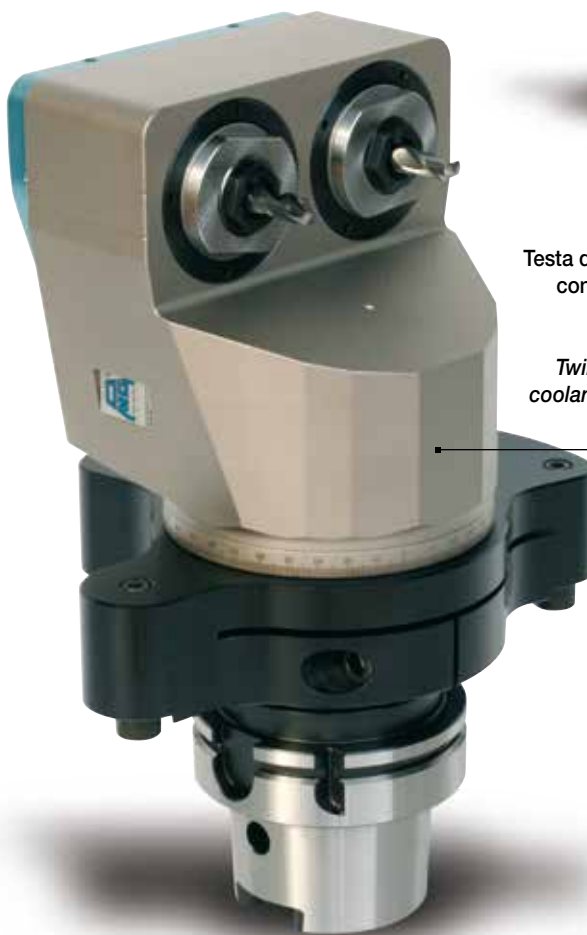

TAS 08606

Testa fresatura conica su acciaio
peso kg 23
*Milling angle head with conical tool
weight kg 23*



TFS 40601

Testa ad angolo biambrino,
angolo tra i due mandrini 176°,
peso Kg 13
*Twin angle head, angle 176°
between spindles, weight Kg 13*



Teste ad angolo speciali

Special angle heads

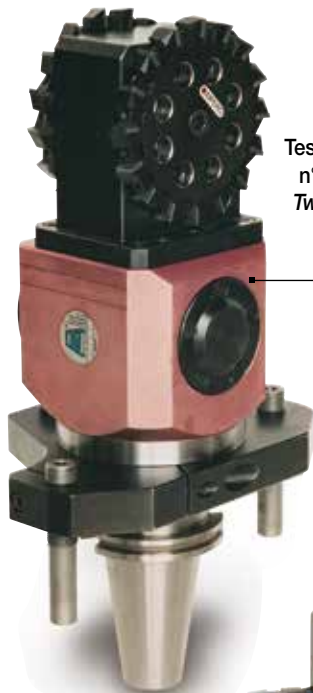

TFS 20298
 Testa bimandrino di fresatura
 n°2 frese Ø 120 peso kg 25
*Twin milling angle head, nr.2
 milling cutter Ø 120
 weight kg 25*



TA 05500
 Testa ad angolo di fresatura
 con fresa Ø125 peso kg 17
*Milling angle head with milling
 cutter Ø 125, weight kg 17*

TAS 20706

Testa per fresatura interna
 pinza freno peso Kg 23
*Angle milling head for brake
 housing weight Kg 23*



TAS 39706

Testa di fresatura per
 supporto motore frese
 Ø160/180 peso kg 31
*Milling head for engine's
 bracket milling cutter
 Ø160/180 weight kg 31*



TA 34397

Testa ad angolo
 di fresatura
 con cono ISO20
 peso kg 0,9
*Milling angle head
 with shank ISO20
 weight kg 0,9*



TFS 39999

Testa ad angolo
 speciale fresatura
 su plastica peso kg 4
*Milling angle head
 for plastic weight kg 4*



TA 17292

Testa ad angolo di fresatura
 n. 2 frese per legno
 peso kg 3
*Twin angle head with nr. 2
 milling cutter for wood
 weight kg 3*



Teste ad angolo speciali

Special angle heads

TAS 37806

Testa ad Angolo di fresatura componente aeronautico, materiale Inconel. Peso Kg 40
Milling Angle Head for aeronautic piece, Inconel alloy material. Weight Kg 40



TFS 23910

Testa ad Angolo bimandrino, fresatura di componente in ghisa. Peso Kg 50
Twin Angle Head, milling cast iron pieces. Weight Kg 50



TFS 31110

Testa ad Angolo di foratura con mandrino HSK50 ribaltato. Peso Kg 31
Drilling Angle Head with HSK50 reverse spindle. Weight Kg 31



TAS 10708

Testa ad Angolo lunghezza mm 1.000, fresatura di cave su acciaio. Peso Kg 216
Angle Head overall length mm 1.000, milling key-way on steel. Weight Kg 216



TAS 13910

Testa ad Angolo di foratura con mandrino ER25. Peso Kg 31
Drilling Angle Head with ER25 spindle. Weight Kg 31



Teste ad angolo speciali

Special angle heads



TFS 05609

Testa ad Angolo di fresatura per tornio verticale.
Peso Kg 286
Milling Angle Head for vertical lathe. Weight Kg 286



TAS 08411

Testa ad Angolo con tre mandrini di foratura con avanzamento idraulico. Peso Kg 17,5
Drilling Angle Head with three spindles, hydraulic spindles feed. Weight Kg 17,5

TFS 26908

Testa ad Angolo bimandrino di foratura per macchina transfer. Peso Kg 9,5
Twin drilling Angle Head for transfer machine. Weight Kg 9,5



TAS 19610
Testa ad Angolo di fresatura per macchina transfer.
Peso Kg 35
Milling Angle Head for transfer machine. Weight Kg 35



TAS 28010

Testa ad Angolo con tre assi a regolazione manuale.
Peso Kg 590
Angle Head with three manual movement axis.
Weight Kg 590



Teste ad angolo speciali

Special angle heads



TAS 19010
Testa ad Angolo di foratura per macchina transfer. Max RPM 20.000.
Peso Kg 5
Drilling Angle Head for transfer machine. Max RPM 20.000. Weight Kg 5



TAS 09407
Testa ad Angolo per fresatura canna di fucile.
Peso Kg 6,5
Milling Angle Head for rifle barrel. Weight Kg 6,5

TAS 16308

Testa ad Angolo di foratura con mandrino HSK32 a cambio automatico utensile. Peso Kg 13,5
Drilling Angle Head with spindle HSK32 with automatic tool changer. Weight Kg 13,5

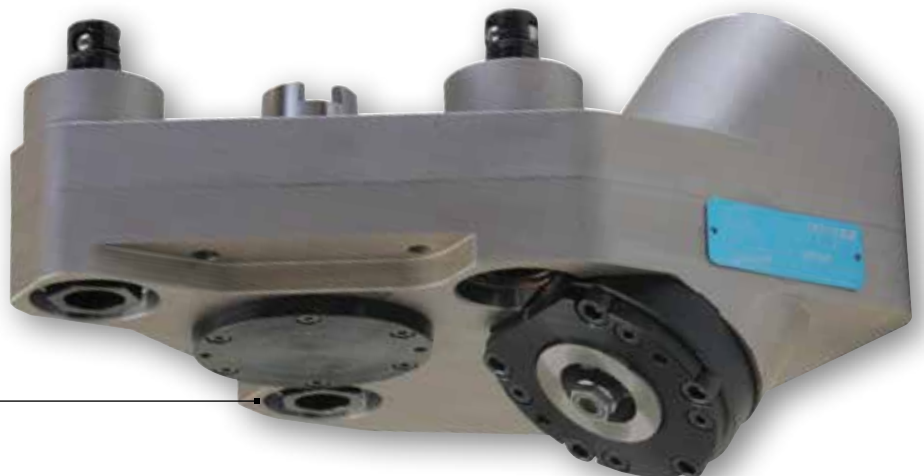

TAS 26810

Testa ad Angolo TAO20, utilizzata in fresatura su torretta a revolver HT250. Peso Kg 14
Milling Angle Head TAO20, assembled on HT250 turret head. Weight Kg 14



TFS 06906
Testa ad Angolo di foratura scatola sterzo. Peso Kg 10
Drilling Angle Head for steering body. Weight Kg 10

