

TSUGAMI

- _____ M06D
- _____ M06SD
- _____ M06SY
- _____ M08D
- _____ M08SD
- _____ M08SY

Toolholder Program

TS65



TSUGAMI

M06D





M06SD

M06SY

M08D

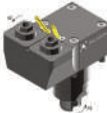
M08SD

M08SY

TS65	Version	Tools Clamping	Center Height	Max. speed	Ratio	External	Internal	Page
	0°	ER25 - DIN6499		8000rpm	i=1:1	RAPPS 25 121UTS65	RAPPS 25 131UTS65	4
		ER32 - DIN6499		8000rpm	i=1:1	RAPPS 32 121UTS65	RAPPS 32 131UTS65	4
		ER25 - DIN6499		8000rpm	i=1:1	RAPPD 25 121UTS65	RAPPD 25 131UTS65	5
	0° Double	ER20 - DIN6499		6000rpm	i=1:1	RAPPTY20 121UTS65		6
	90°	ER25 - DIN6499	65 mm	8000rpm	i=1:1	RRPPS 25 121UTS65	RRPPS 25 131UTS65	7
		ER32 - DIN6499	65 mm	8000rpm	i=1:1	RRPPS 32 121UTS65	RRPPS 32 131UTS65	7
		ER25 - DIN6499	85 mm	8000rpm	i=1:1	RRPPS 25 321UTS65		7
		ER32 - DIN6499	85 mm	8000rpm	i=1:1	RRPPS 32 321UTS65	RRPPS 32 331UTS65	7
		ER32 - DIN6499	85 mm	8000rpm	i=1:1	RRPPS 32 321RTS65		7
		ER25 - DIN6499	85 mm	8000rpm	i=1:1	RRPPA 25 321UTS65	RRPPA 25 331UTS65	8
ER32 - DIN6499	85 mm	8000rpm	i=1:1	RRPPA 32 321UTS65	RRPPS 32 331UTS65	8		
	90° Double	ER25 - DIN6499	85 mm	8000rpm	i=1:1	RRPPTA25 321UTS65		9
		ER32 - DIN6499	85 mm	8000rpm	i=1:1	RRPPTA32 321UTS65		9
	90° Quadruple	ER20 - DIN6499	103 mm	6000rpm	i=1:1	RRPPQY20 421UTS65		9
	±90°	ER20 - DIN6499		6000rpm	i=1:1	ROPPS 20 121UTS65	ROPPS 20 131UTS65	10

TSUGAMI

M06D









M06SD

M06SY



M08D

M08SD

M08SY

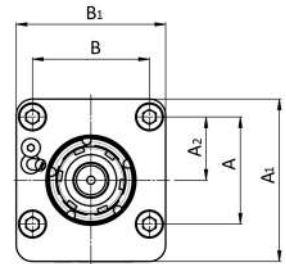
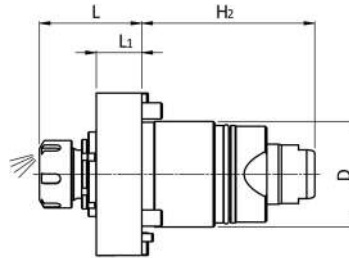



TS65	Version	Tools Clamping	Center Height	Coolant	ALGRA Part No.	Page
	O.D. cutting holder	□ 25mm	H:65mm	External	E10/US 25 TS65X65	11
		□ 1"	H:65mm	External	E10/US 1" TS65X65	11
	O.D. double holder	□ 25mm	H:65mm	External	E10/UD 25 TS65X65	11
		□ 1"	H:65mm	External	E10/UD 1" TS65X65	11
	O.D. Y-axis double toolholders for both spindle	□ 20mm	H:85mm	External	E10/UQ 20 TS65X85	12
		□ 0.75"	H:85mm	External	E10/UQ 0.75" TS65X85	12
	Face and I.D. cutting holder	□ 25mm	H:100mm	External	E10/UA 25 TS65X100	12
		□ 1"	H:100mm	External	E10/UA 1" TS65X100	12
	Blade holder	□ 32mm	H:93mm	External	E10/TT 32 TS65X93	13
	Boring Bar holder	∅ 40mm	H:85mm	Int/Ext	E10/B 40 TS65X85	13
		∅ 1.5"	H:85mm	Int/Ext	E10/B 1.5" TS65X85	13
	Boring Bar holder	∅ 40mm	H:101mm	Int/Ext	E10/BA 40 TS65X101	14
		∅ 1.5"	H:101mm	Int/Ext	E10/BA 1.5" TS65X101	14
	Boring Bar holder	∅ 40mm	H:54mm/101mm	Int/Ext	E10/BD 40 TS65X54/101	14
		∅ 1.5"	H:54mm/101mm	Int/Ext	E10/BA 1.5" TS65X54/101	14



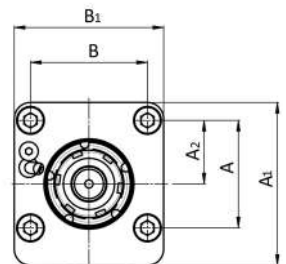
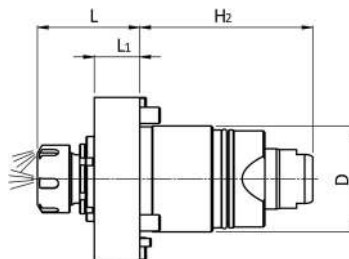



1/TS65			Codice code - code - Bestell Nr.	D	ER	H	H1	H2	L (min-max)	L1	L2	A	B	A1	B1	A2	B2	M ₂ Nm	n ₂ min-1	P kW
0°			RAPPS 25 121UTS65	65	25			106,5	55-60	28		66	72	100	92	39		40	8000	8
			RAPPS 32 121UTS65	65	32			106,5	62-67	28		66	72	100	92	39		40	8000	8
																				

4

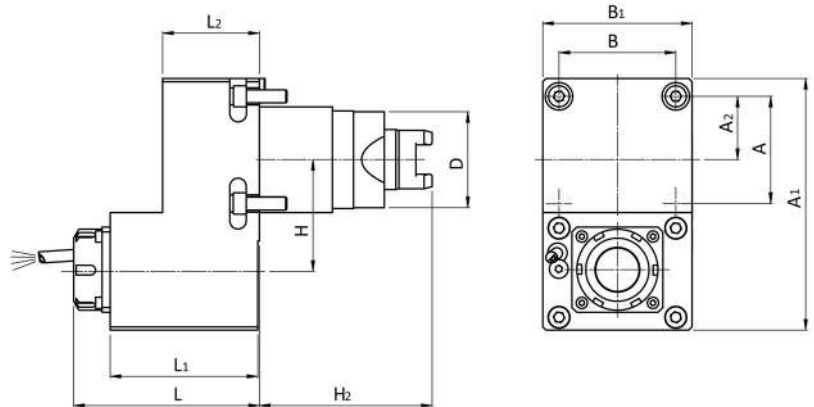





2/TS65			Codice code - code - Bestell Nr.	D	ER	H	H1	H2	L (min-max)	L1	L2	A	B	A1	B1	A2	B2	M ₂ Nm	n ₂ min-1	P kW
0°			RAPPS 25 131UTS65	65	25			106,5	55-60	28		66	72	100	92	39		40	8000	8
			RAPPS 32 131UTS65	65	32			106,5	62-67	28		66	72	100	92	39		40	8000	8
																				
																				
																				

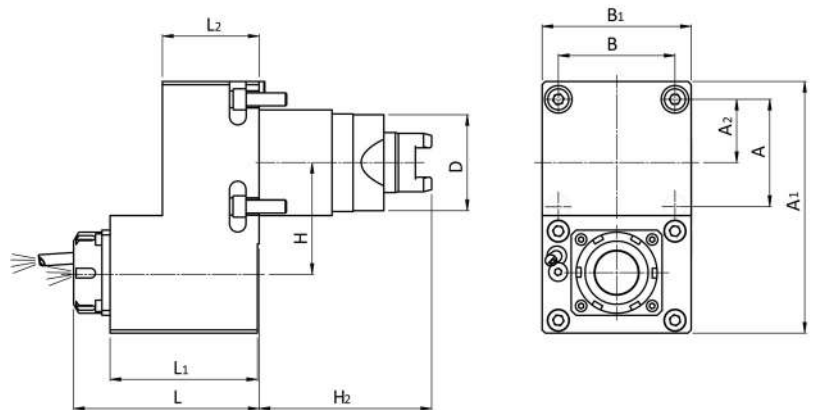



3/TS65			Codice	D	ER	H	H1	H2	L	L1	L2	A	B	A1	B1	A2	B2	M ₂	n ₂	P	
			code - code - Bestell Nr.						(min-max)									Nm	min-1	kW	
0°			RAPPD 25 121UTS65	65	25	55		106,5	93-98	90	60	66	72	155	96	39		40	8000	8	
																					



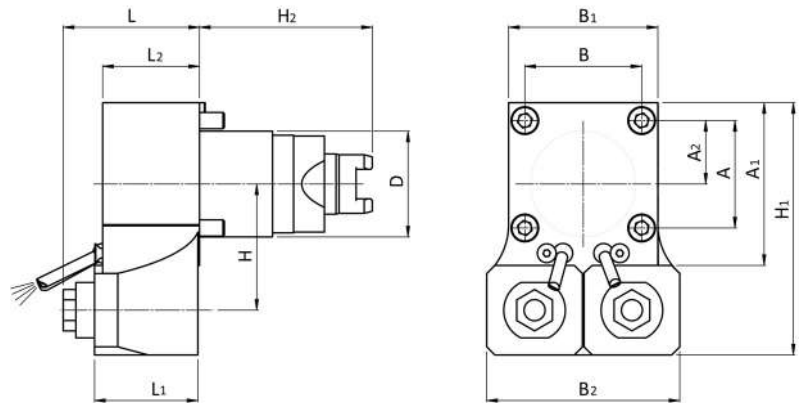
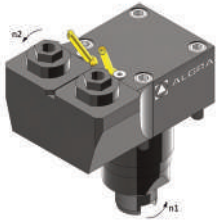

4/TS65			Codice	D	ER	H	H1	H2	L	L1	L2	A	B	A1	B1	A2	B2	M ₂	n ₂	P	
			code - code - Bestell Nr.						(min-max)									Nm	min-1	kW	
0°			RAPPD 25 131UTS65	65	25	55		106,5	93-98	90	60	66	72	155	96	39		40	8000	8	
																					



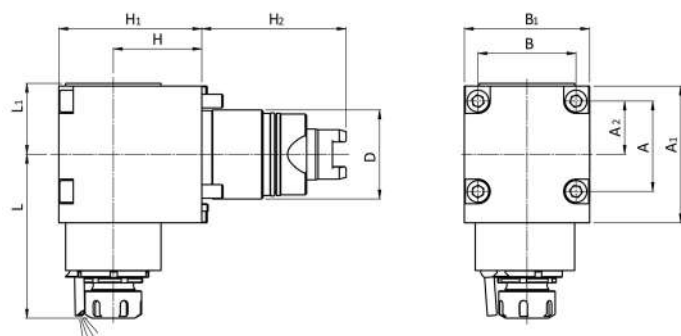



5/TS65			Codice	D	ER	H	H1	H2	L	L1	L2	A	B	A1	B1	A2	B2	M ₂	n ₂	P
			code - code - Bestell Nr.						(min-max)									Nm	min-1	kW
0°			RAPPTY20 121UTS65	65	20	77,5	155	106,5	84-89	76	60	66	72	100	92	39	119	45	6000	4,5
 EXTERNAL																				

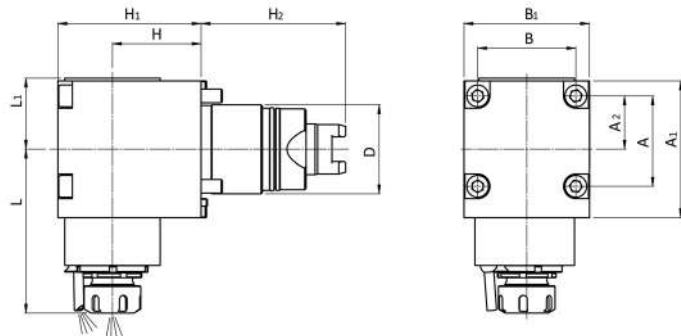



6/TS65			Codice	D	ER	H	H1	H2	L	L1	L2	A	B	A1	B1	A2	B2	M ₂	n ₂	P	
			code - code - Bestell Nr.						(min-max)									Nm	min-1	kW	
90°			RRPPS 25 121UTS65	65	25	65	105	106,5	117,3-120	60		66	72	100	92	39		40	8000	8	
			RRPPS 32 121UTS65	65	32	65	105	106,5	124-127	60		66	72	100	92	39			40	8000	8
			RRPPS 25 321UTS65	65	25	85	118	106,5	117,3-120	60		66	72	100	92	39			40	8000	8
			RRPPS 32 321UTS65	65	32	85	118	106,5	117,3-120	60		66	72	100	92	39			40	8000	8
 EXTERNAL																					



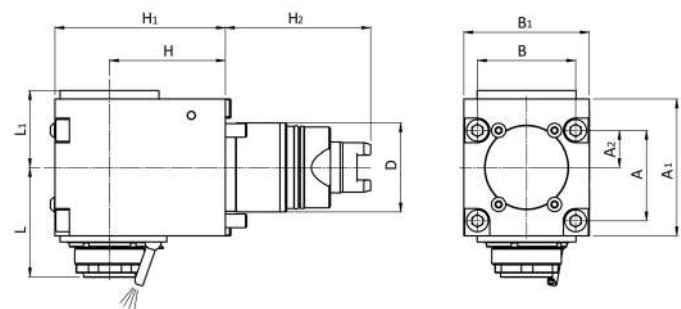



7/TS65			Codice code - code - Bestell Nr.	D	ER	H	H1	H2	L (min-max)	L1	L2	A	B	A1	B1	A2	B2	M ₂ Nm	n ₂ min-1	P kW
90°			RRPPS 25 131UTS65	65	25	65	105	106,5	117-122	60		66	72	100	92	39		40	8000	8
			RRPPS 32 131UTS65	65	32	65	105	106,5	124-127	60		66	72	100	92	39		40	8000	8
			RRPPS 25 331UTS65	65	25	85	118	106,5	117-122	60		66	72	100	92	39		40	8000	8
			RRPPS 32 331UTS65	65	32	85	118	106,5	124-127	60		66	72	100	92	39		40	8000	8

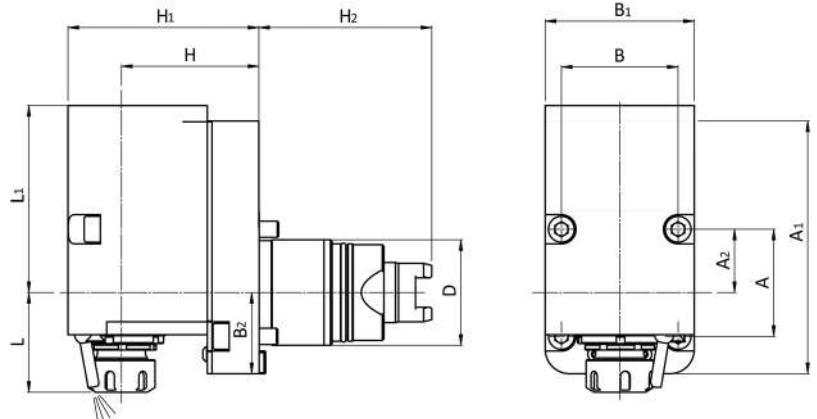





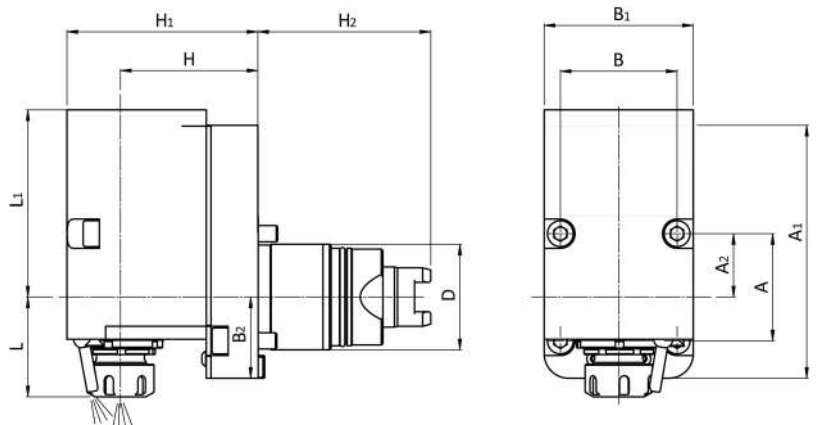

8/TS65			Codice code - code - Bestell Nr.	D	ER	H	H1	H2	L (min-max)	L1	L2	A	B	A1	B1	A2	B2	M ₂ Nm	n ₂ min-1	P kW
90°			RRPPS 32 321RTS65	65	32	85	125	106,5	76-81	56,5		66	72	100	92	27		70	8000	8
																				





9/TS65		Codice code - code - Bestell Nr.	D	ER	H	H1	H2	L (min-max)	L1	L2	A	B	A1	B1	A2	B2	M ₂ Nm	n ₂ min-1	P kW
 90°	 DIN 6499	 +1 (1:1)	RRPPA 25 321UTS65	65	25	85	118	106,5	58-63	115	66	72	155	92	39	40	8000	8	
			RRPPA 32 321UTS65	65	32	85	118	106,5	65÷70	115	66	72	155	92	39	40	8000	8	
 EXTERNAL																			



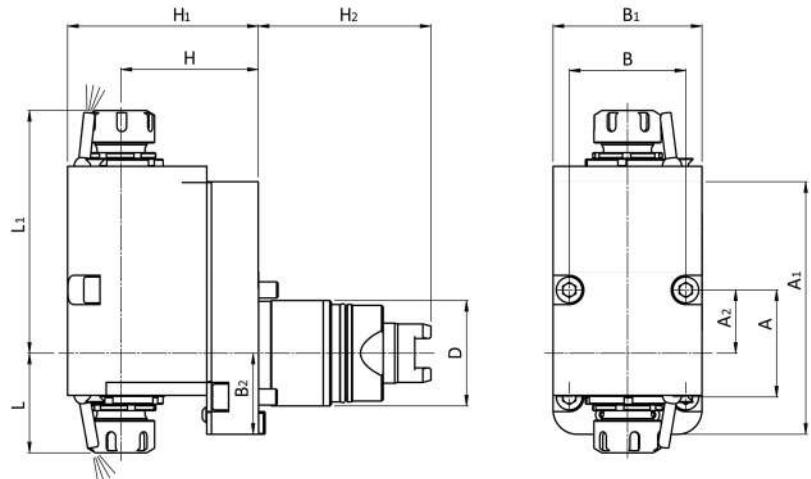

10/TS65		Codice code - code - Bestell Nr.	D	ER	H	H1	H2	L (min-max)	L1	L2	A	B	A1	B1	A2	B2	M ₂ Nm	n ₂ min-1	P kW
 90°	 DIN 6499	 +1 (1:1)	RRPPA 25 331UTS65	65	25	85	118	106,5	57,8-61,5	115	66	72	155	92	39	50	40	8000	8
			RRPPA 32 331UTS65	65	32	85	118	106,5	65÷70	115	66	72	155	92	39	40	8000	8	
 INT./EXT.	 100 bar	 Filtration 30µm																	



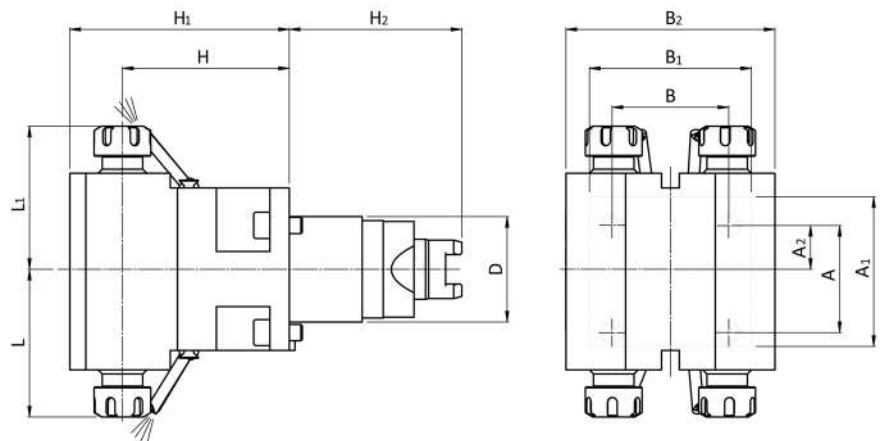



11/TS65		Codice code - code - Bestell Nr.	D	ER	H	H1	H2	L (min-max)	L1	L2	A	B	A1	B1	A2	B2	M ₂ Nm	n ₂ min-1	P kW
 90°	 DIN 6499	 +1 (1:1)	RRPPTA25 321UTS65	65	25	85	118	106,5	56,5-61,5	150	66	72	155	92	39	40	8000	8	
			RRPPTA32 321UTS65	65	32	85	118	106,5	65-70	150	66	72	155	92	39	40	8000	8	



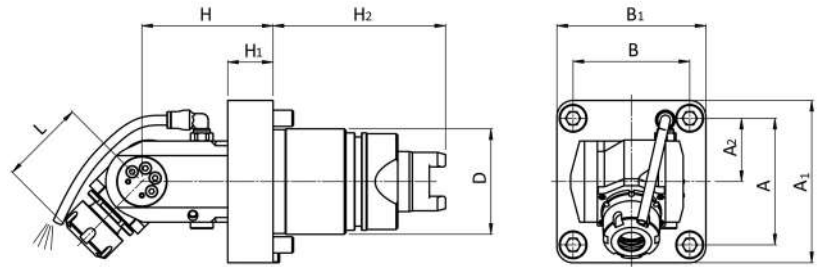



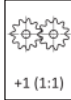

12/TS65		Codice code - code - Bestell Nr.	D	ER	H	H1	H2	L (min-max)	L1	L2	A	B	A1	B1	A2	B2	M ₂ Nm	n ₂ min-1	P kW
 90°	 DIN 6499	 +1 (1:1)	RRPPQY20 421UTS65	65	20	103	136	106,5	83-88	91	66	72	100	92	27	129	40	6000	3,5

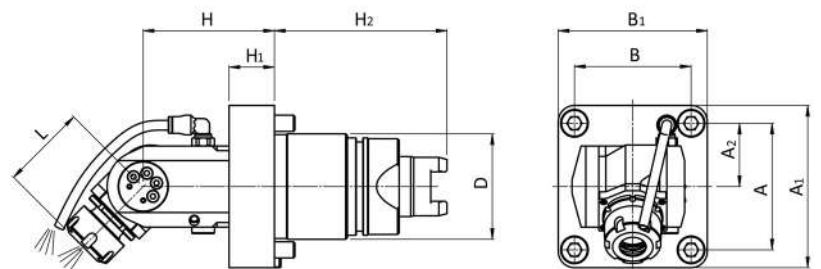





13/TS65			Codice	D	ER	H	H1	H2	L	L1	L2	A	B	A1	B1	A2	B2	M ₂	n ₂	P
			code - code - Bestell Nr.						(min-max)									Nm	min-1	kW
  			ROPPS 20 121UTS65	65	20	65	12		49-52	115		66	72	100	92	39		15	8000	3
																				



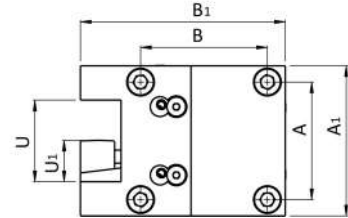
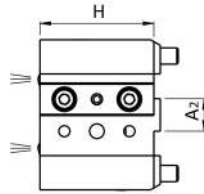

14/TS65			Codice	D	ER	H	H1	H2	L	L1	L2	A	B	A1	B1	A2	B2	M ₂	n ₂	P
			code - code - Bestell Nr.						(min-max)									Nm	min-1	kW
  			ROPPS 20 131UTS65	65	20	65	12		49-52	115		66	72	100	92	39		15	8000	3
  																				



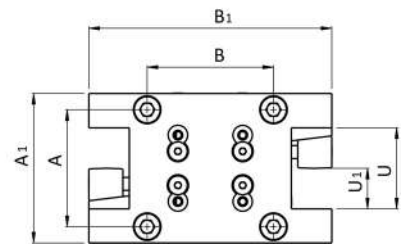
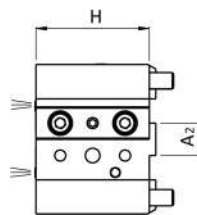

101/TS65		Codice code - code - Bestell Nr.	U	U1	U2	H	H1	H2	H3	A	B	A1	B1	A2	B2	B3
 	E10/US 25 TS65X70		50	25		70				72	78	92	126	20		
	E10/US 1" TS65X70		2"	1"		70				72	78	92	126	20		



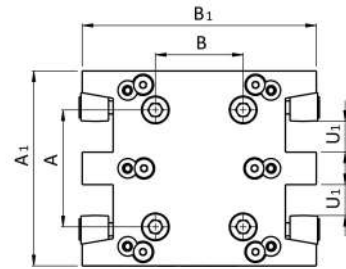
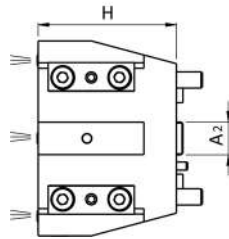

102/TS65		Codice code - code - Bestell Nr.	U	U1	U2	H	H1	H2	H3	A	B	A1	B1	A2	B2	B3
 	E10/UD 25 TS65X70		50	25		70				72	78	92	150	20		
	E10/UD 1" TS65X70		2"	1"		70				72	78	92	126	20		



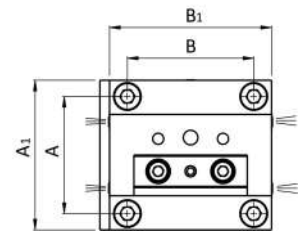
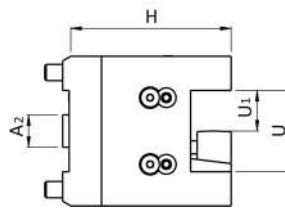

103/TS65		Codice code - code - Bestell Nr.	U	U1	U2	H	H1	H2	H3	A	B	A1	B1	A2	B2	B3
  EXTERNAL	E10/UQ 20 TS65X85			20		85				72	54	120	144	20		
	E10/UQ 0.75" TS65X85			0.75"		85				72	54	120	144	20		



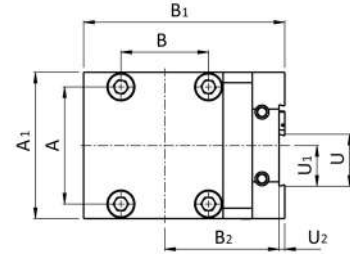
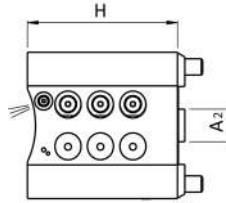

104/TS65		Codice code - code - Bestell Nr.	U	U1	U2	H	H1	H2	H3	A	B	A1	B1	A2	B2	B3
  EXTERNAL	E10/UA 25 TS65X100		50	25		100				72	78	92	100	20		
	E10/UA 1" TS65X100		2"	1"		100				72	78	92	100	20		



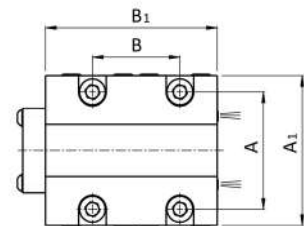
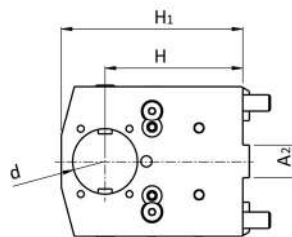

105/TS65	Codice code - code - Bestell Nr.	U	U1	U2	H	H1	H2	H3	A	B	A1	B1	A2	B2	B3
  EXTERNAL	E10/TT 32 TS65X93	32	25	2,36	93				72	54	90	124	20	70,5	



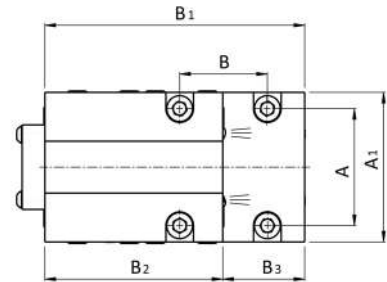
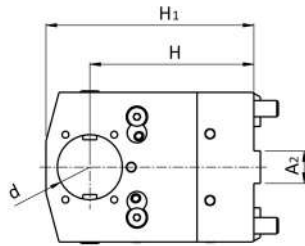

106/TS65	Codice code - code - Bestell Nr.	d	d1	d2	H	H1	H2	H3	A	B	A1	B1	A2	B2	B3
  INT./EXT.	E10/B 40 TS65X85	∅ 40			85	112			72	54	92	106	20		
	E10/B 1.5" TS65X85	∅ 1,5"			85	112			72	54	92	106	20		

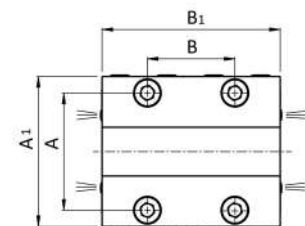
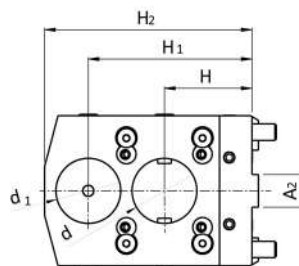

107/TS65		Codice code - code - Bestell Nr.	d	d1	d2	H	H1	H2	H3	A	B	A1	B1	A2	B2	B3
  INT./EXT.	E10/BA 40 TS65X101		Ø 40			101	128			72	54	92	160	20	110	50
	E10/BA 1.5" TS65X101		Ø 1.5"			101	128			72	54	92	160	20	110	50



108/TS65		Codice code - code - Bestell Nr.	d	d1	d2	H	H1	H2	H3	A	B	A1	B1	A2	B2	B3
  INT./EXT.	E10/BD 40 TS65X54/101		Ø 40	40		54	101	128		72	54	92	110	20		
	E10/BD 1.5" TS65X54/101		Ø 1.5"	1"		54	101	128		72	54	92	110	20		

**La produzione:
il lavoro**

Production:
work

La produzione viene sviluppata nella moderna struttura a temperatura controllata di Almenno San Salvatore, mentre negli stabilimenti di Brembilla (I-Bergamo) vengono effettuate le lavorazioni di montaggio ed assemblaggio di gruppi completi. La superficie coperta delle strutture è di mq. 15.000, dei quali mq. 1.000 sono adibiti agli uffici amministrativi, commerciali e tecnici. L'attività produttiva si svolge con l'utilizzo di impianti e macchinari CNC costantemente aggiornati alle nuove tecnologie ed in grado di sviluppare le seguenti lavorazioni:

- Asportazione di truciolo
- Elettroerosione
- Tornitura orizzontale e verticale
- Fresatura universale 5 assi
- Fresatura/tornitura
- Lappatura per fori e piani
- Rettifica in tondo interno ed esterno
- Rettifica in tangenziale oltre al montaggio di gruppi e sottogruppi completi.

The production is developed in the modern, temperature controlled facility in Almenno San Salvatore, with Brembilla factories there are the assembly operations and the assembly of complete groups. The facilities covered area is of 15,000 sqm., 1,000 sqm. of which are used for the administrative commercial and technical offices. The production cycle takes place with the use of CNC fixtures and equipment constantly updated with new technologies and able to develop the following machining:

- Chip machining
- Electroerosion
- Horizontal and vertical turning
- 5-axis universal milling
- Milling/turning
- Lapping for holes and plane surfaces
- Cylindrical internal and external grinding
- Tangential grinding in addition to the assembly of complete groups and subassemblies.

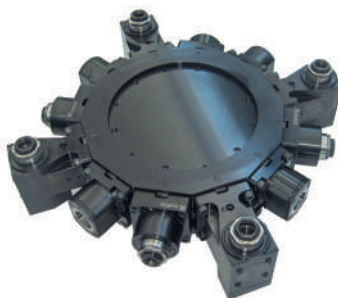
**Certificazioni:
uno standard
qualitativo**

Certification:
a quality
standard

La tecnologia avanzata svolge un ruolo chiave nell'obiettivo di incrementare il proprio valore, quello dei propri prodotti, dei servizi e della capacità del personale, operando nel rispetto delle norme UNI EN ISO 9001:2008 e ISO 14001:2004. L'alto livello di sensibilità verso il rispetto delle regole di sicurezza e dell'ambiente è presente ed immediatamente percepito in tutte le strutture aziendali.

Advanced technology plays a key role aiming to increase its value and the products, services and staff capacity value, operating in compliance with UNI EN ISO 9001:2008 and ISO 14001:2004.

The high level of sensitivity towards the observance of safety rules and the environment is present and perceived immediately in all facilities.



UNI EN ISO 9001:2008 - Cert. n° 0141



UNI EN ISO 14001:2004 - Cert. n° 0270A



ALGRA S.p.A. Divisione accessori
Via Manzoni, 41 24031 Almenno S. Salvatore (BG)
Tel. +39 035.64.20.51 • Fax +39 035.64.01.28
algra.accessori@algra.it - www.algra.it