

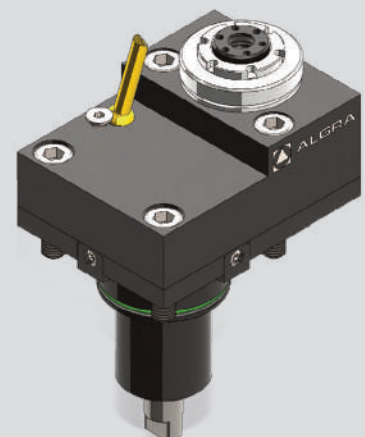

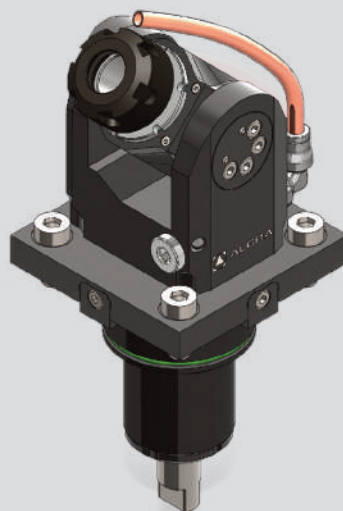

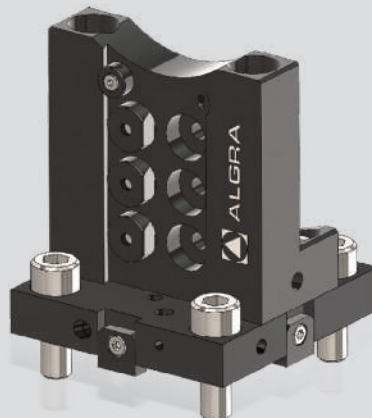

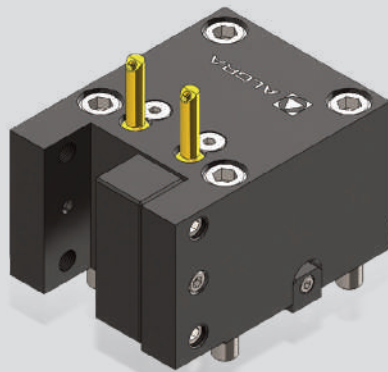







BMT55



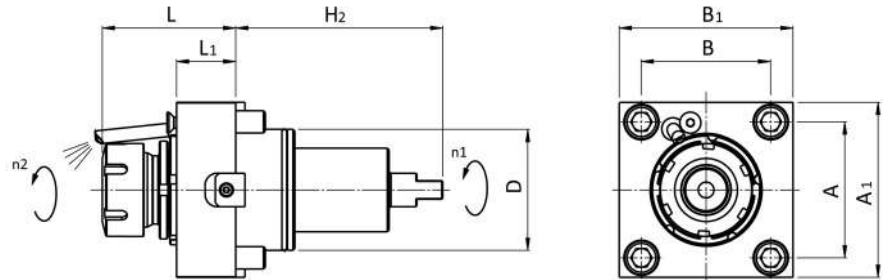



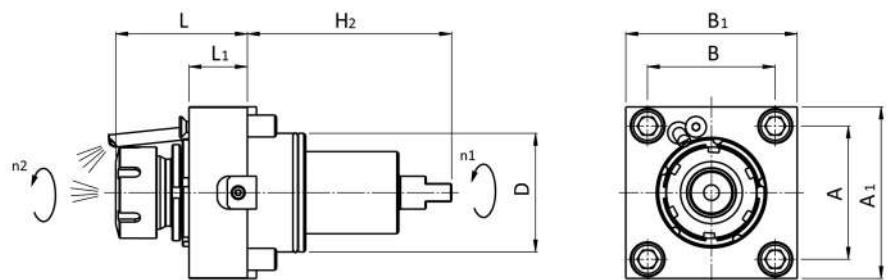
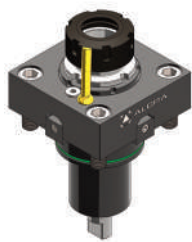

BMT55	Version	Tools Clamping	Center Height	Max. speed	Ratio	External	Internal	Page
	0°	ER25 - DIN6499 ER16 - DIN6499 ER16 - DIN6499		8000rpm 32000rpm 16000rpm	i=1:1 i=1:4 i=1:2	RAPPS 25 121UT55 RAPPS 16 122UT55 RAPPD 16 1222UT55	RAPPS 25 131UT55	4 5 5
	90°	ER25 - DIN6499 ER25 - DIN6499 ER25 - DIN6499 ER25 - DIN6499 ER16 - DIN6499 ER16 - DIN6499 Ø16mm - DIN6358 Ø16mm - DIN6358 Ø16mm - DIN6358 Ø16mm - DIN6358	60mm 70mm 85mm 100mm 70mm 80mm 60mm 70mm 85mm 100mm	8000rpm 8000rpm 8000rpm 8000rpm 32000rpm 16000rpm 8000rpm 8000rpm 8000rpm 8000rpm	i=1:1 i=1:1 i=1:1 i=1:1 i=1:4 i=1:2 i=1:1 i=1:1 i=1:1 i=1:1	RRPPS 25 121UT55 RRPPS 25 321UT55 RRPPS 25 421UT55 RRPPS 25 521UT55 RRPPS 16 122UT55 RRPPS 16 4222UT55 RRPFS 16 121UT55 RRPFS 16 321UT55 RRPFS 16 421UT55 RRPFS 16 521UT55	RRPPS 25 131UT55 RRPPS 25 331UT55 RRPPS 25 431UT55 RRPPS 25 531UT55	6 6 6 6 7 7 7 7 7 7
	90° Double	ER25 - DIN6499 ER25 - DIN6499 ER25 - DIN6499 ER25 - DIN6499	60mm 70mm 85mm 100mm	8000rpm 8000rpm 8000rpm 8000rpm	i=1:1 i=1:1 i=1:1 i=1:1	RRPPT 25 121UT55 RRPPT 25 321UT55 RRPPT 25 421UT55 RRPPT 25 521UT55		8 8 8 8
	±90°	ER20 - DIN6499		8000rpm	i=1:1	ROPFS 20 121UT55	ROPFS 20 131UT55	9

BMT55	Version	Tools Clamping	Center Height	Coolant	ALGRA Part No.	Page
	O.D. cutting holder	□ 25mm	H:65mm	External	E10/U 25 T55X65	10
		□ 1"	H:65mm	External	E10/U 1" T55X65	10
	O.D. double holder	□ 25mm	H:85mm	External	E10/UD 25 T55X85	10
		□ 1"	H:85mm	External	E10/UD 1" T55X85	10
	Face and I.D. cutting holder	□ 20mm	H:84mm	External	E10/UAD20 T55X84	11
		□ 0.75"	H:84mm	External	E10/UAD0.75" T55X84	11
	Blade Holder	∥ 26mm	H:100mm	External	E10/TT 26 T55X100	11
	Index cutting holder	□ 25mm	H:102mm	External	E12/IDS25 T55X102	12
		□ 1"	H:102mm	External	E12/IDS1" T55X102	12
	Boring Bar holder	∅ 40mm	H:60mm	Int/Ext	E10/B 40 T55X60	12
		∅ 40mm	H:70mm	Int/Ext	E10/B 40 T55X70	12
		∅ 1.5"	H:70mm	Int/Ext	E10/B 1.5" T55X70	12
		∅ 40mm	H:95mm	Int/Ext	E10/B 40 T55X95	12
		∅ 1.5"	H:95mm	Int/Ext	E10/B 1.5" T55X95	12
	Boring Bar holder	∅ 20mm	H:95mm	Int/Ext	E10/BN 20 T55X95	13
		∅ 25mm	H:95mm	Int/Ext	E10/BN 25 T55X95	13
		∅ 32mm	H:95mm	Int/Ext	E10/BN 32 T55X95	13
		∅ 0.75"	H:95mm	Int/Ext	E10/BN 0.75" T55X95	13
		∅ 1"	H:95mm	Int/Ext	E10/BN 1" T55X95	13
		∅ 1.25"	H:95mm	Int/Ext	E10/BN 1.25" T55X95	13
	Boring Bar holder	∅ 25mm	H:65mm/110mm	Int/Ext	E10/BD 25 T55X65/110	13
		∅ 1"	H:65mm/110mm	Int/Ext	E10/BD 1" T55X65/110	13
	Index Boring Bar holder	∅ 32mm/25mm	H:70mm	Int/Ext	E12/IBD32/25 T55X70	14
		∅ 1.5"/1"	H:70mm	Int/Ext	E12/IBD1.5"/1" T55X70	14
	Boring Bar holder	∅ 20mm	H:65mm/90mm/115mm	Int/Ext	E10/BQ 20 T55X65/115	14
		∅ 0.75"	H:65mm/90mm/115mm	Int/Ext	E10/BQ 0.75" T55X65/115	14







1/BMT55			Codice	D	ER	H	H1	H2	L	L1	L2	A	B	A1	B1	A2	B2	M ₂	n ₂	P
			code - code - Bestell Nr.						(min-max)									Nm	min-1	kW
  			RAPPS 25 121UT55	55	25			104	53,5-57,2	25		64	64	85	85			40	8000	
																				

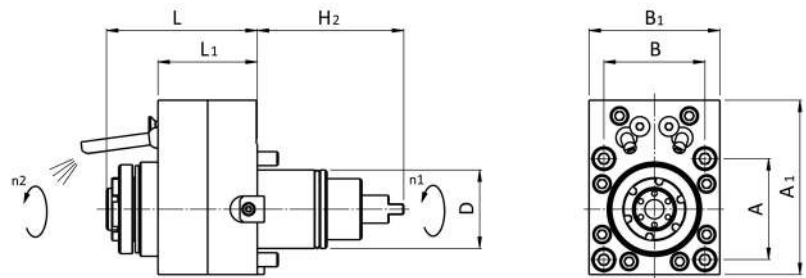





2/BMT55			Codice	D	ER	H	H1	H2	L	L1	L2	A	B	A1	B1	A2	B2	M ₂	n ₂	P
			code - code - Bestell Nr.						(min-max)									Nm	min-1	kW
  			RAPPS 25 131UT55	55	25			104	53,5-57,2	25		64	64	85	85			40	8000	8
  																				

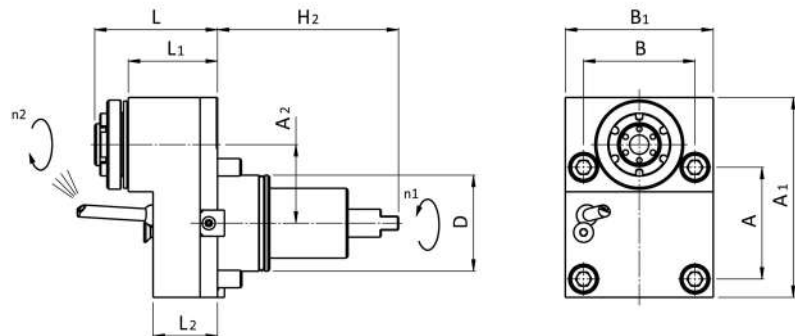





3/BMT55			Codice	D	ER	H	H1	H2	L	L1	L2	A	B	A1	B1	A2	B2	M ₂	n ₂	P
			code - code - Bestell Nr.						(min-max)									Nm	min-1	kW
  			RAPPS 16 122UT55	55	16			104	82,5-86,5	57		64	64	100	75			12	32000	3
																				

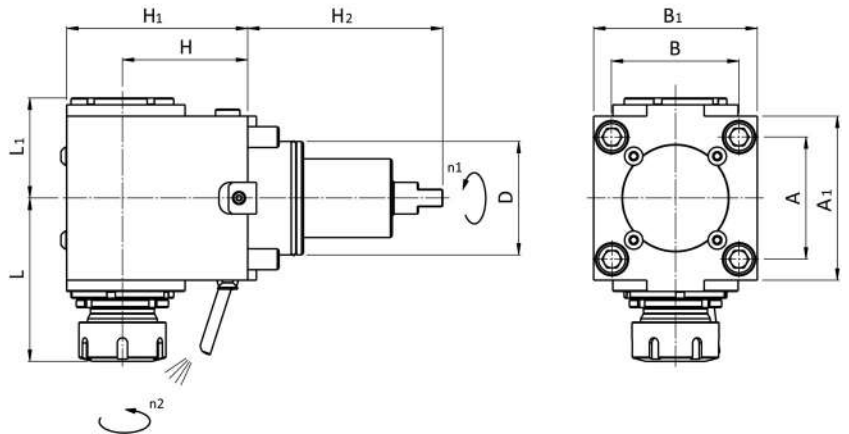





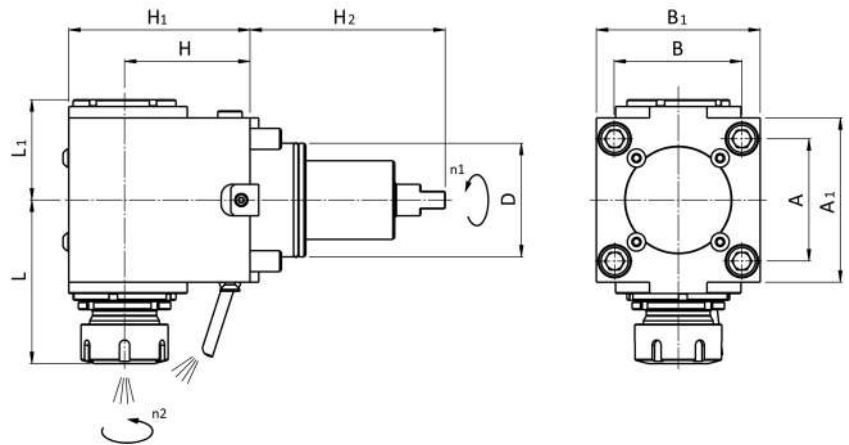

4/BMT55			Codice	D	ER	H	H1	H2	L	L1	L2	A	B	A1	B1	A2	B2	M ₂	n ₂	P
			code - code - Bestell Nr.						(min-max)									Nm	min-1	kW
  			RAPPD 16 1222UT55	55	16			104	66,8-70,5	51,3	37	64	64	114,5	85	45		15	16000	4
																				



5/BMT55			Codice code - code - Bestell Nr.	D	ER	H	H1	H2	L (min-max)	L1	L2	A	B	A1	B1	A2	B2	M ₂ Nm	n ₂ min-1	P kW	
  	 EXTERNAL	 -1 (1:1)	RRPPS 25 121UT55	55	25	60	90	104	81,2-84,9	52,2		64	64	85	85			40	8000	8	
			RRPPS 25 321UT55	55	25	70	100	104	81,2-84,9	52,2			64	64	85	85			40	8000	8
			RRPPS 25 421UT55	55	25	85	115	104	81,2-84,9	52,2			64	64	85	85			40	8000	8
			RRPPS 25 521UT55	55	25	100	130	104	81,2-84,9	52,2			64	64	85	85			40	8000	8



6/BMT55			Codice code - code - Bestell Nr.	D	ER	H	H1	H2	L (min-max)	L1	L2	A	B	A1	B1	A2	B2	M ₂ Nm	n ₂ min-1	P kW		
  	 INT./EXT.	 80 bar	 Filtration 30µm	RRPPS 25 131UT55	55	25	60	90	104	81,2-84,9	52,2		64	64	85	85			40	8000	8	
				RRPPS 25 331UT55	55	25	70	100	104	81,2-84,9	52,2			64	64	85	85			40	8000	8
				RRPPS 25 431UT55	55	25	85	115	104	81,2-84,9	52,2			64	64	85	85			40	8000	8
				RRPPS 25 531UT55	55	25	100	130	104	81,2-84,9	52,2			64	64	85	85			40	8000	8

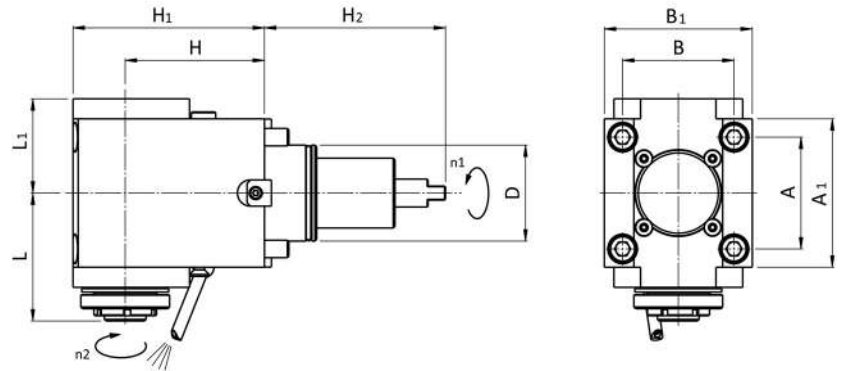

7/BMT55		Codice code - code - Bestell Nr.	D	ER	H	H1	H2	L (min-max)	L1	L2	A	B	A1	B1	A2	B2	M ₂ Nm	n ₂ min-1	P kW
		RRPPS 16 122UT55	55	16	70	100	104	66-69,7	52,5		64	64	85	85			12	32000	3

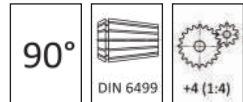



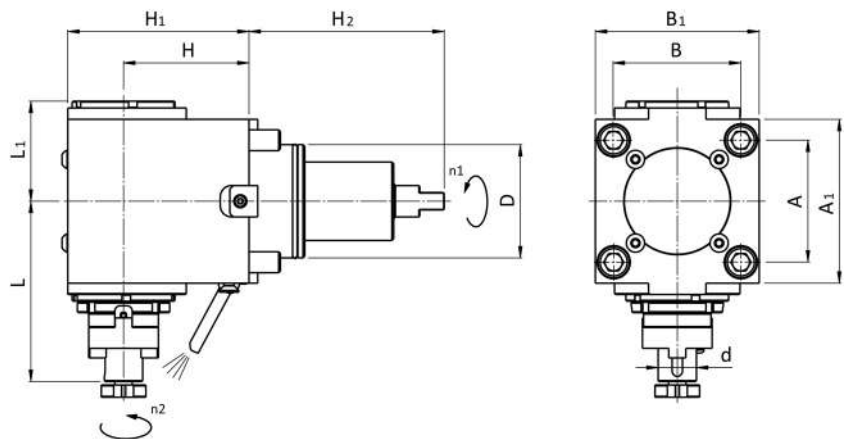
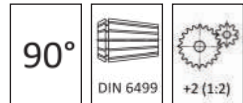

7/BMT55		Codice code - code - Bestell Nr.	D	ER	H	H1	H2	L (min-max)	L1	L2	A	B	A1	B1	A2	B2	M ₂ Nm	n ₂ min-1	P kW
		RRPPS 16 422UT55	55	16	80	110	104	69,6-73,3	54		64	64	85	85			15	16000	4

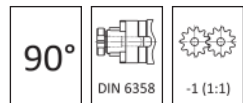

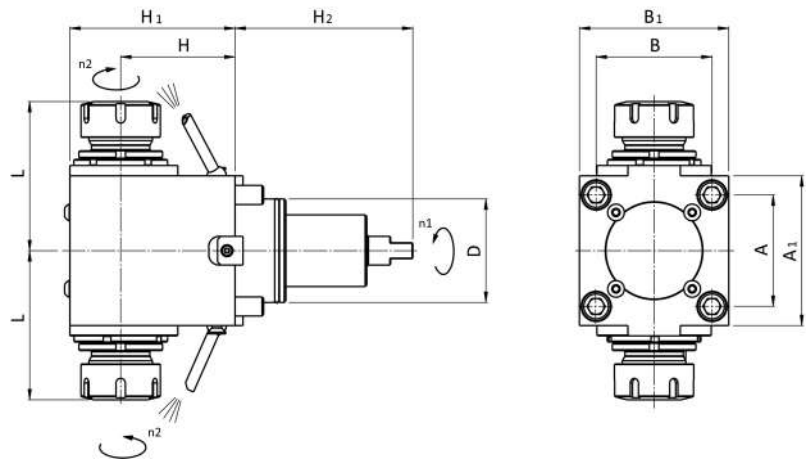



8/BMT55		Codice code - code - Bestell Nr.	D	d	H	H1	H2	L	L1	L2	A	B	A1	B1	A2	B2	M ₂ Nm	n ₂ 1	P kW
		RRPFS 16 121UT55	55	Ø16	60	90	104	95	52,2		64	64	85	85			40	8000	8
		RRPFS 16 321UT55	55	Ø16	70	100	104	95	52,2		64	64	85	85			40	8000	8
		RRPFS 16 421UT55	55	Ø16	85	115	104	95	52,2		64	64	85	85			40	8000	8
		RRPFS 16 521UT55	55	Ø16	100	130	104	95	52,2		64	64	85	85			40	8000	8



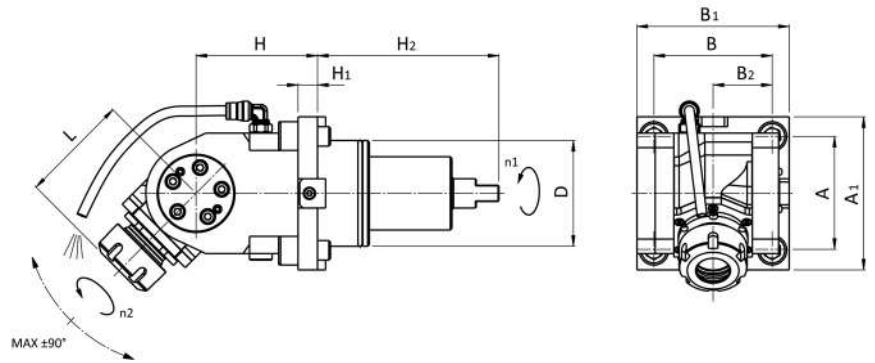





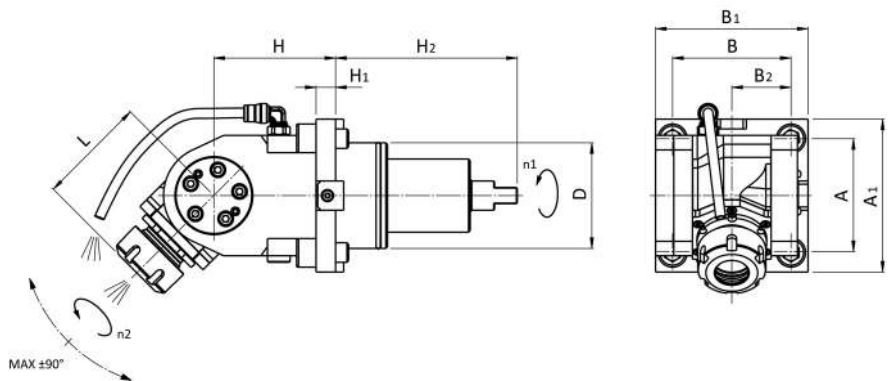

9/BMT55			Codice	D	ER	H	H1	H2	L	L1	L2	A	B	A1	B1	A2	B2	M ₂	n ₂	P	
			code - code - Bestell Nr.						(min-max)									Nm	min-1	kW	
   ±1 (1:1)	 EXTERNAL	RRPPT 25 121UT55	55	25	60	90	104	81,2-84,9				64	64	85	85			40	8000	8	
		RRPPT 25 321UT55	55	25	70	100	104	81,2-84,9					64	64	85	85			40	8000	8
		RRPPT 25 421UT55	55	25	85	115	104	81,2-84,9					64	64	85	85			40	8000	8
		RRPPT 25 521UT55	55	25	100	130	104	81,2-84,9					64	64	85	85			40	8000	8





10/BMT55		Codice code - code - Bestell Nr.	D	ER	H	H1	H2	L (min-max)	L1	L2	A	B	A1	B1	A2	B2	M ₂ Nm	n ₂ min-1	P kW
±90°	 DIN 6499	 +1 (1:1)	ROPPS 20 121UT55	55	20	65	12	104	48,8-52,5			64	64	85	85	32	15	8000	3
 EXTERNAL																			



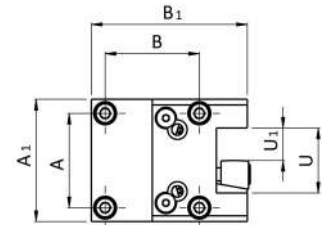
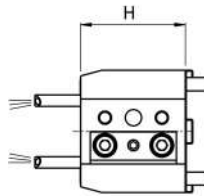

11/BMT55		Codice code - code - Bestell Nr.	D	ER	H	H1	H2	L (min-max)	L1	L2	A	B	A1	B1	A2	B2	M ₂ Nm	n ₂ min-1	P kW
±90°	 DIN 6499	 +1 (1:1)	ROPPS 20 131UT55	55	20	65	12	104	48,8-52,5			64	64	85	85	32	15	8000	3
 INT./EXT.	 80 bar	 Filtration 30µm																	



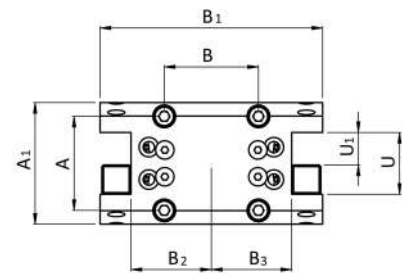
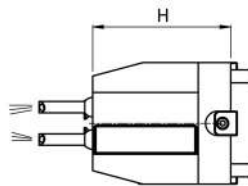

101/BMT55	Codice code - code - Bestell Nr.	U	U1	U2	H	H1	H2	H3	A	B	A1	B1	A2	B2	B3
	E10/U 25 T55X65	50	25		65				64	64	85	111			
 EXTERNAL	E10/U 1" T55X65	2"	1"		65				64	64	85	111			



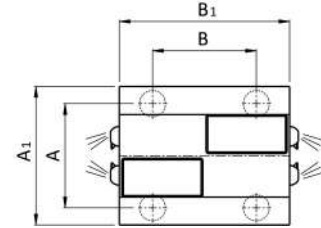
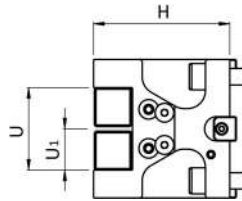

102/BMT55	Codice code - code - Bestell Nr.	U	U1	U2	H	H1	H2	H3	A	B	A1	B1	A2	B2	B3
	E10/UD 25 T55X85	50	25		85				64	64	85	155		57	57
 EXTERNAL	E10/UD 1" T55X85	2"	1"		85				64	64	85	155		57	57



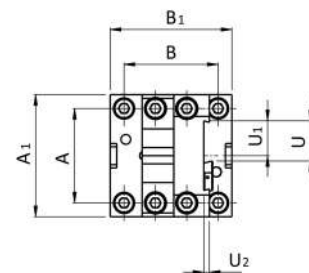
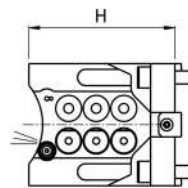

103/BMT55		Codice code - code - Bestell Nr.	U	U1	U2	H	H1	H2	H3	A	B	A1	B1	A2	B2	B3
 	E10/UAD20 T55X84		40	20		84				64	64	85	105			
	E10/UAD0.75" T55X84		1.5"	0.75"		84				64	64	85	105			



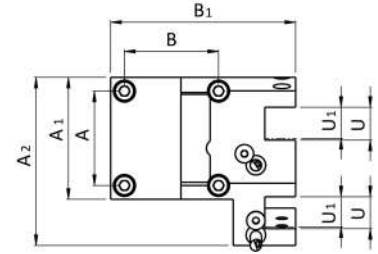
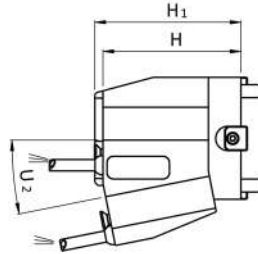

104/BMT55		Codice code - code - Bestell Nr.	U	U1	U2	H	H1	H2	H3	A	B	A1	B1	A2	B2	B3
 	E10/TT 26 T55X100		26	21	2,36	100				64	64	85	85			



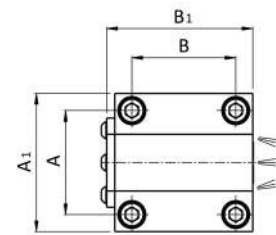
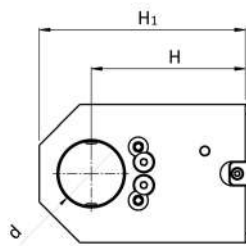

105/BMT55		Codice code - code - Bestell Nr.	U	U1	U2	H	H1	H2	H3	A	B	A1	B1	A2	B2	B3
  EXTERNAL	E12/IDS25 T55X102	26,5	25	15°	102	110				64	64	85	121	135		
	E12/IDS1" T55X102	26,5	1"	15°	102	110				64	64	85	121	135		



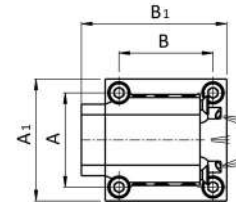
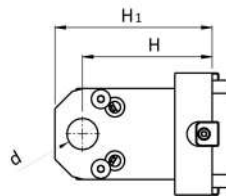

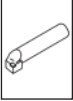
106/BMT55		Codice code - code - Bestell Nr.	d	d1	d2	H	H1	H2	H3	A	B	A1	B1	A2	B2	B3
  INT./EXT.	E10/B 40 T55X60	∅ 40			60	92				64	64	85	90			
	E10/B 40 T55X70	∅ 40			70	102				64	64	85	90			
	E10/B 1.5" T55X70	∅ 1.5"			70	102				64	64	85	90			
	E10/B 40 T55X95	∅ 40			95	125				64	64	85	90			
	E10/B 1.5" T55X95	∅ 1.5"			95	125				64	64	85	90			



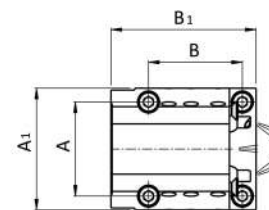
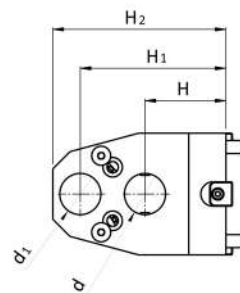

107/BMT55		Codice code - code - Bestell Nr.	d	d1	d2	H	H1	H2	H3	A	B	A1	B1	A2	B2	B3
  INT./EXT.	E10/BN 20 T55X95		Ø 20			95	130			64	64	85	100			
	E10/BN 25 T55X95		Ø 25			95	130			64	64	85	100			
	E10/BN 32 T55X95		Ø 32			95	135			64	64	85	100			
	E10/BN 0.75" T55X95		Ø 0.75"			95	130			64	64	85	100			
	E10/BN 1" T55X95		Ø 1"			95	130			64	64	85	100			
	E10/BN 1.25" T55X95		Ø 1.25"			95	135			64	64	85	100			



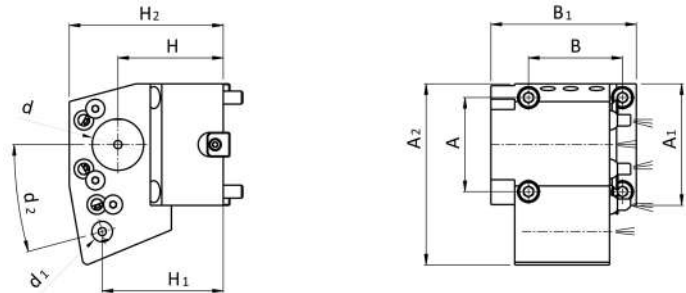

108/BMT55		Codice code - code - Bestell Nr.	d	d1	d2	H	H1	H2	H3	A	B	A1	B1	A2	B2	B3
  INT./EXT.	E10/BD 25 T55X65/110		Ø 25	Ø 25		65	110	130		64	64	85	90			
	E10/BD 1" T55X65/110		Ø 1"	Ø 1"		65	110	130		64	64	85	90			

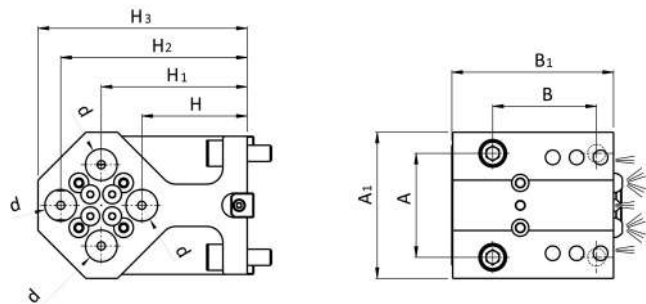

109/BMT55		Codice code - code - Bestell Nr.	d	d1	d2	H	H1	H2	H3	A	B	A1	B1	A2	B2	B3
  INT./EXT.		E12/IBD32/25 T55X70	Ø 32	Ø 25	15°	70	61,4	110		64	64	85	100	130		
		E12/IBD1.5"/1" T55X70	Ø 1.5"	Ø 1"	15°	70	61,4	110		64	64	85	100	130		



110/BMT55		Codice code - code - Bestell Nr.	d	d1	d2	H	H1	H2	H3	A	B	A1	B1	A2	B2	B3
  INT./EXT.		E10/BQ 20 T55X65/115	Ø 20			65	90	115	120	64	64	90	100			
		E10/BQ 0.75" T55X65/115	Ø 0.75"			65	90	115	120	64	64	90	100			

**La produzione:
il lavoro**Production:
work

La produzione viene sviluppata nella moderna struttura a temperatura controllata di Almenno San Salvatore, mentre negli stabilimenti di Brembilla (I-Bergamo) vengono effettuate le lavorazioni di montaggio ed assemblaggio di gruppi completi. La superficie coperta delle strutture è di mq. 15.000, dei quali mq. 1.000 sono adibiti agli uffici amministrativi, commerciali e tecnici. L'attività produttiva si svolge con l'utilizzo di impianti e macchinari CNC costantemente aggiornati alle nuove tecnologie ed in grado di sviluppare le seguenti lavorazioni:

- Asportazione di truciolo
- Elettroerosione
- Tornitura orizzontale e verticale
- Fresatura universale 5 assi
- Fresatura/tornitura
- Lappatura per fori e piani
- Rettifica in tondo interno ed esterno
- Rettifica in tangenziale oltre al montaggio di gruppi e sottogruppi completi.

The production is developed in the modern, temperature controlled facility in Almenno San Salvatore, with Brembilla factories there are the assembly operations and the assembly of complete groups. The facilities covered area is of 15,000 sqm., 1,000 sqm. of which are used for the administrative commercial and technical offices. The production cycle takes place with the use of CNC fixtures and equipment constantly updated with new technologies and able to develop the following machining:

- Chip machining
- Electroerosion
- Horizontal and vertical turning
- 5-axis universal milling
- Milling/turning
- Lapping for holes and plane surfaces
- Cylindrical internal and external grinding
- Tangential grinding in addition to the assembly of complete groups and subassemblies.

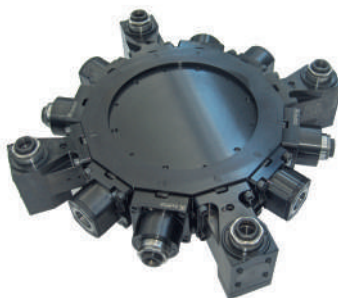
**Certificazioni:
uno standard
qualitativo**Certification:
a quality
standard

La tecnologia avanzata svolge un ruolo chiave nell'obiettivo di incrementare il proprio valore, quello dei propri prodotti, dei servizi e della capacità del personale, operando nel rispetto delle norme UNI EN ISO 9001:2008 e ISO 14001:2004. L'alto livello di sensibilità verso il rispetto delle regole di sicurezza e dell'ambiente è presente ed immediatamente percepito in tutte le strutture aziendali.

Advanced technology plays a key role aiming to increase its value and the products, services and staff capacity value, operating in compliance with UNI EN ISO 9001:2008 and ISO 14001:2004.

The high level of sensitivity towards the observance of safety rules and the environment is present and perceived immediately in all facilities.



UNI EN ISO 9001:2008 - Cert. n° 0141

UNI EN ISO 14001:2004 - Cert. n° 0270A



ALGRA S.p.A. Divisione accessori
Via Manzoni, 41 24031 Almenno S. Salvatore (BG)
Tel. +39 035.64.20.51 • Fax +39 035.64.01.28
algra.accessori@algra.it - www.algra.it