

MN210-26

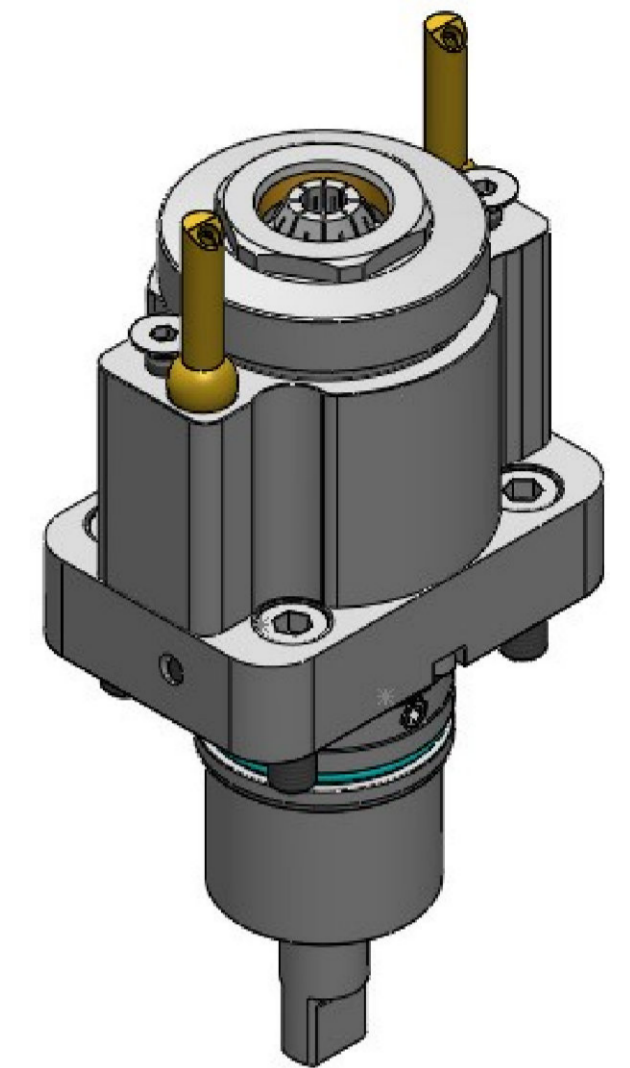

Do not run without coolant!  
Only use filtered coolant fluid  
(max. particle size = 30 µm)

Coolant Pressure Variation

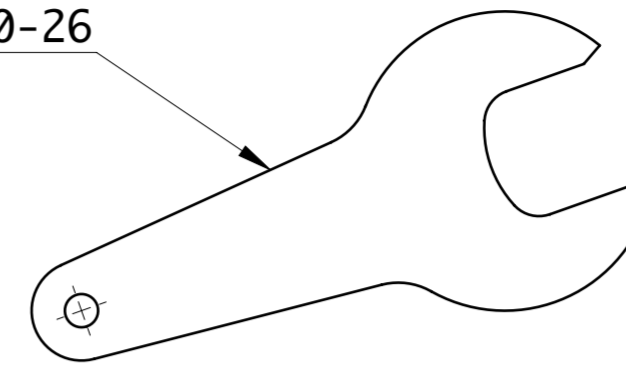
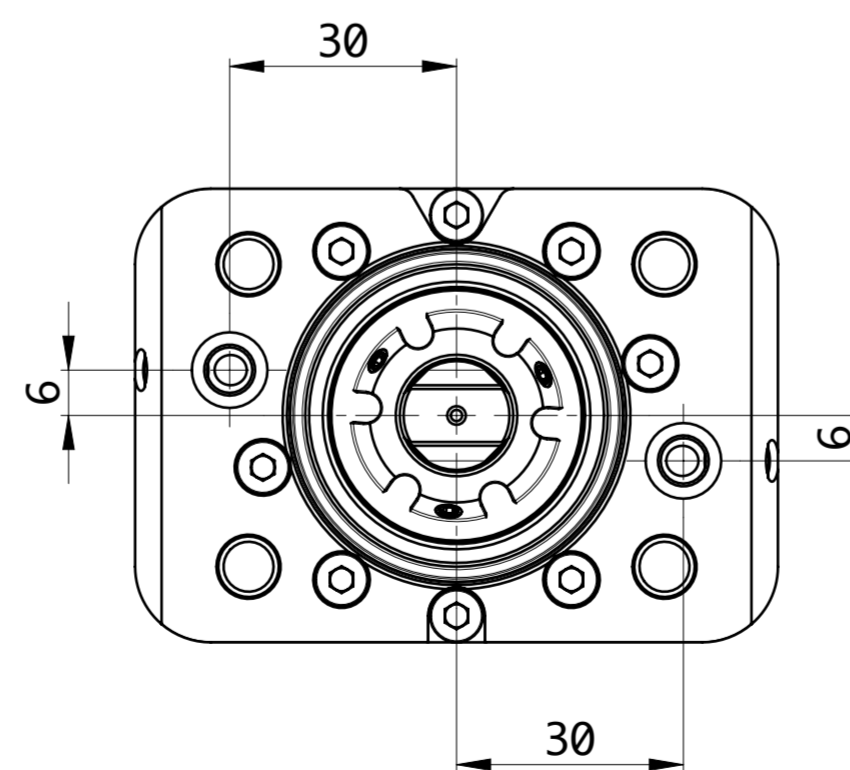
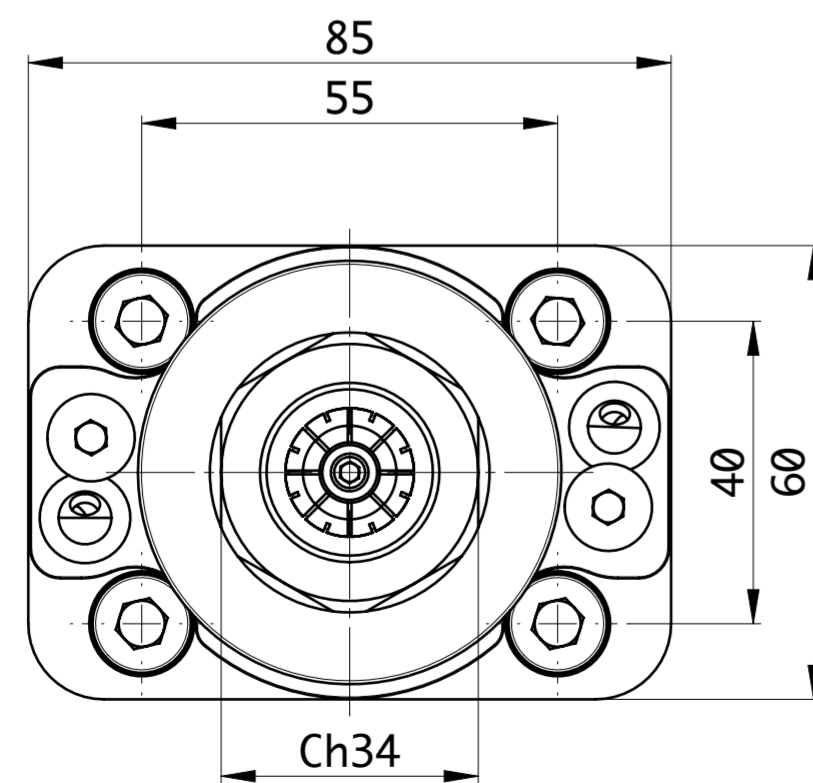
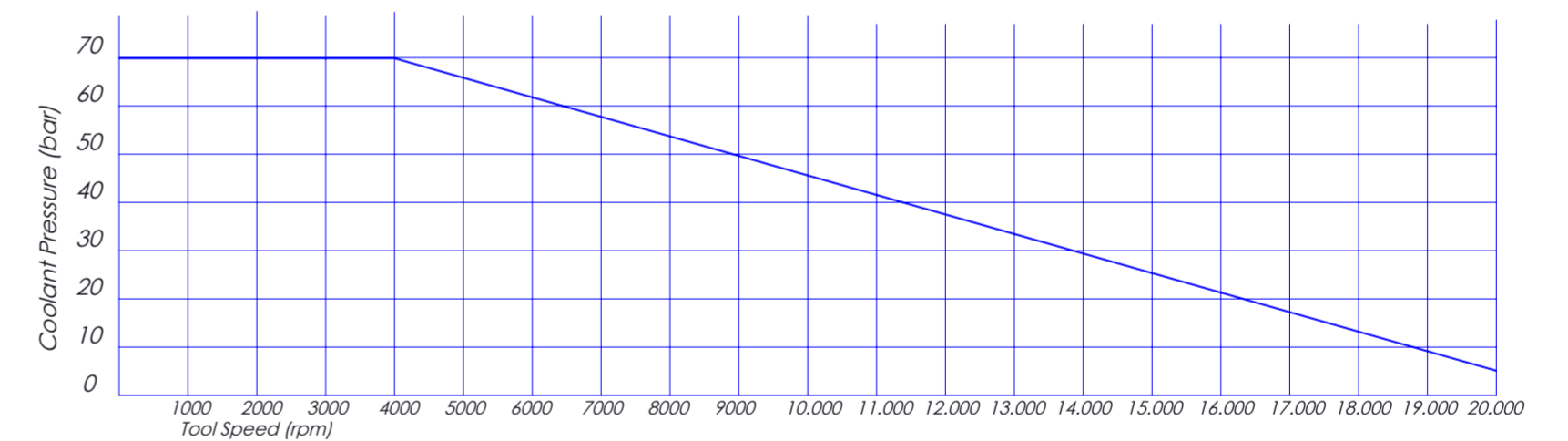

Commercial Code:		<b>RAPPS 16 132UN44</b>	
Denomination:		<b>DRIVEN TOOL 0° - INT/EXT COOLANT</b>	Item Code: <b>AMN210-A</b>
Speed Max (out)	24'000 rpm	Max Power	2.5 Kw
Ratio n1 : n2	4:1	T2. Max	Nm
Pressure Max	70 bar	Filtration	30 µm
Weight	2.541 Kg	Output	DIN 6499 - ER16

Info:  
ALGRA S.p.A.  
Via Manzoni 41, I-24031  
Almenno S.Salvatore (BG)  
Tel. +39 035642051  
Fax +39 035640128  
algra.accessori@algra.it