

UC GOLD CHUCK (UC16) High Vibration Damping Type

UC 黃金夾頭刀柄 (UC16) 高阻尼減震型

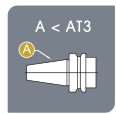

Taper tolerance
錐度公差

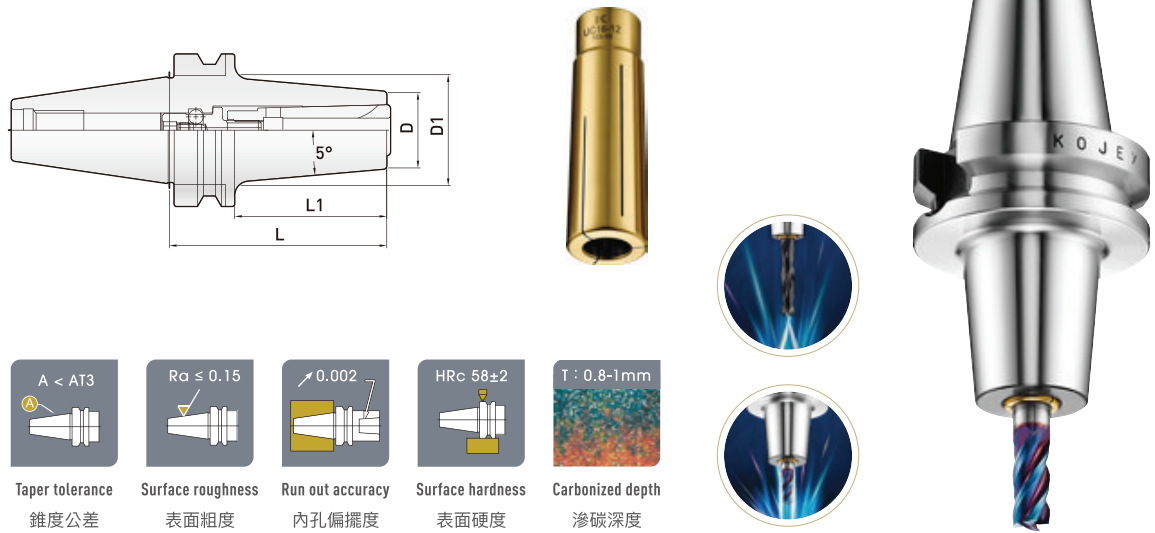

Surface roughness
表面粗度

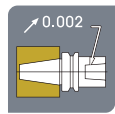

Run out accuracy
內孔偏擺度



Surface hardness
表面硬度

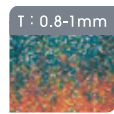

Carbonized depth
滲碳深度

Order Code 訂購編號	L	L1	D	D1	Min-1G2.5 動態平衡	Spanner 扳手規格	Recommended Torsion 推薦鎖固扭力	Torque Wrench 扭力扳手	Center Coolant 中心出水	Side Coolant 側面出水	Pin Collet Pin筒夾
BT30-UC16-70	70	48	32	40	30,000	M6	15Nm	TW30+M06100	✓	✓	X
BT40-UC16-70	70	43	40	47	30,000	M6	15Nm	TW30+M06100	✓	✓	X
UC16-90	90	63	32	40	30,000	M6	15Nm	TW30+M06100	✓	✓	X
UC16-120	120	93	32	-	30,000	M6	15Nm	TW30+M06160	✓	✓	X
BT50-UC16-120	120	78	32	42	20,000	M6	15Nm	TW30+M06160	✓	✓	X
UC16-150	150	108	32	52	20,000	M6	15Nm	TW30+M06200	✓	✓	X

- Provide the center coolant and the side coolant.
- Select the side coolant must to use the collet with coolant slot, please check p.20
- Select the general collet for center coolant, please check p.19
- Coolant can be sprayed directly into the edge of tool for quick cooling and remove the steel chip.

- 可以選擇中心出水及側面出水的功能。
- 側面出水必須選用有水槽的夾頭，請參閱 p.20
- 中心出水選用一般的夾頭，請參閱 p.19
- 冷却液可直接噴到刀尖位置，可快速冷却及去除鐵屑。

