

REGO-FIX HI-Q/ERAX 16 with external thread

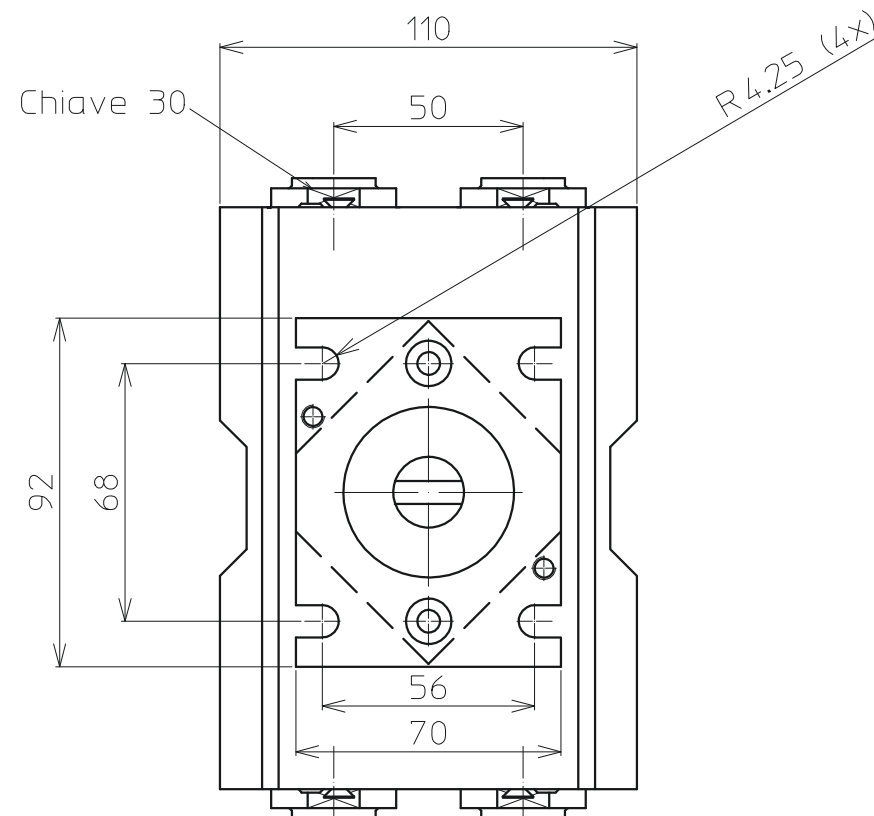

RRPPTY16 121UM45

TECHNICAL FEATURES:
 DOUBLE OUTPUT 2+2 DRIVEN TOOL
 FOR ER 16 COLLET DIN 6499-B
 OUTPUT SPINDLE CERAMIC COATED
 HELICAL GEARS GROUND INVOLUTE
 BEARINGS IN ABEC8 PRECISION CLASS
 INPUT ROTATION LH-RH
 OUTPUT ROTATION RH
 TRANSMISSION RATIO 1:1
 N2 RPM MAX 6000
 MAX POWER 2.9 kw
 M2 MAX 25 Nm
 KLUBER NBU 15 GREASE