

8

7

6

5

4

3

2

1

TECHNICAL DATA	V75100X
JAW WIDTH	2.95" (75.00mm)
BASE LENGTH	3.94" (100.00mm)
MAXIMUM TORQUE (JAW BOLT)	35 ft-lb (47.45 Nm)
CLAMPING FORCE	5000 lbf @ 45 ft-lb (22.24kN @ 61.01 Nm)
MAXIMUM TORQUE (LEADSCREW)	45 ft-lb (61.01 Nm)
MAXIMUM TORQUE (MOUNTING BOLT)	35 ft-lb (47.45 Nm)
SELF-CENTERING ACCURACY	± 0.0005" (± 12.7µm)

V75100X

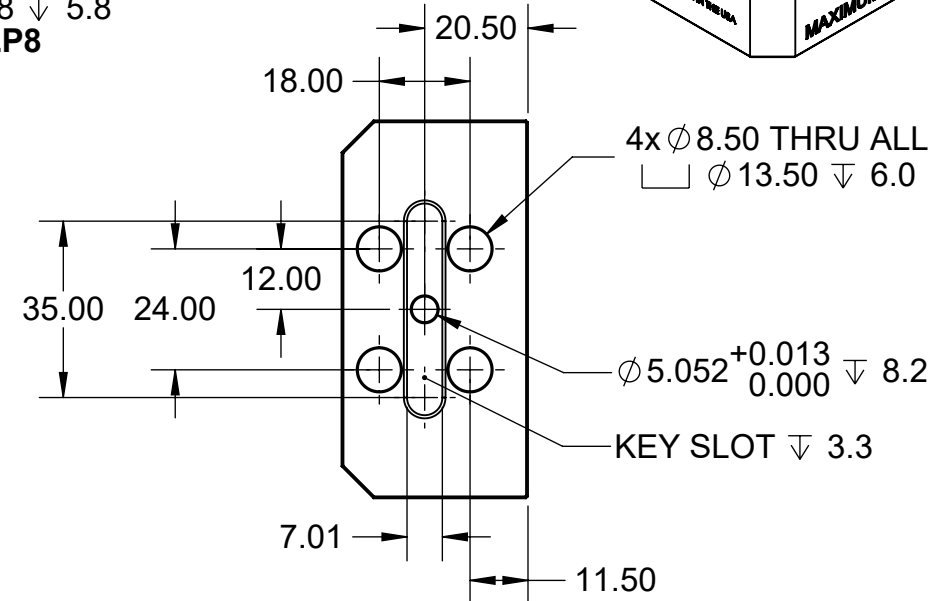
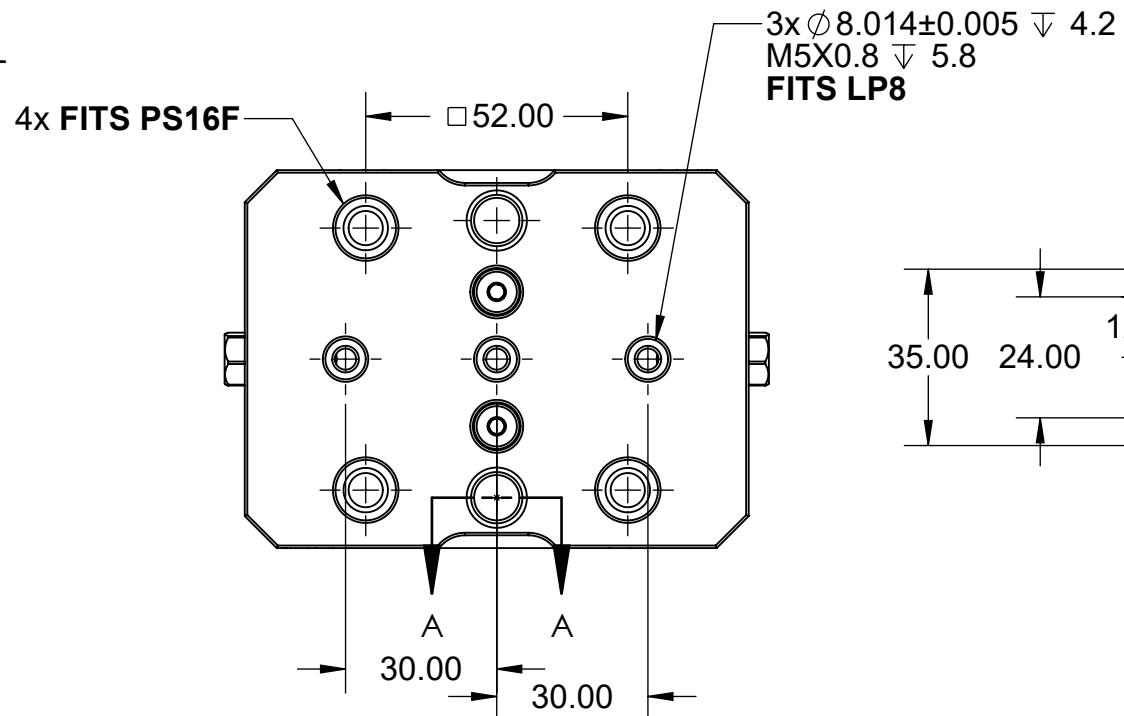
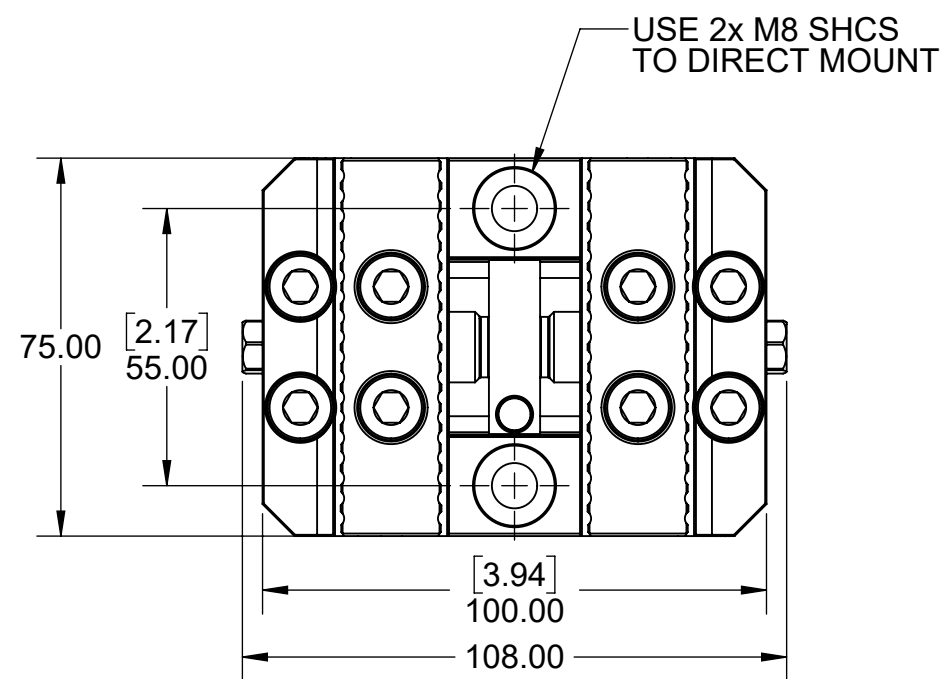
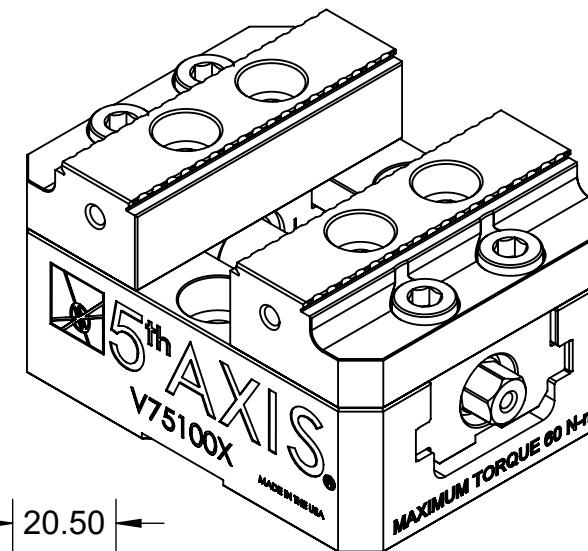

JAW MOUNTING

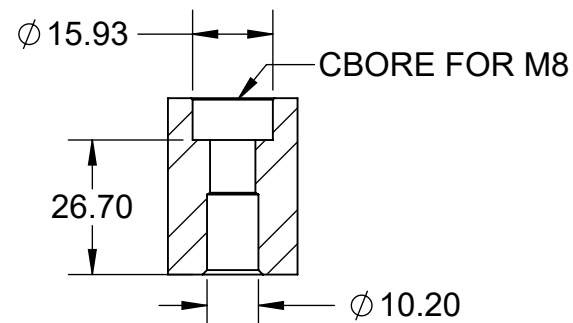
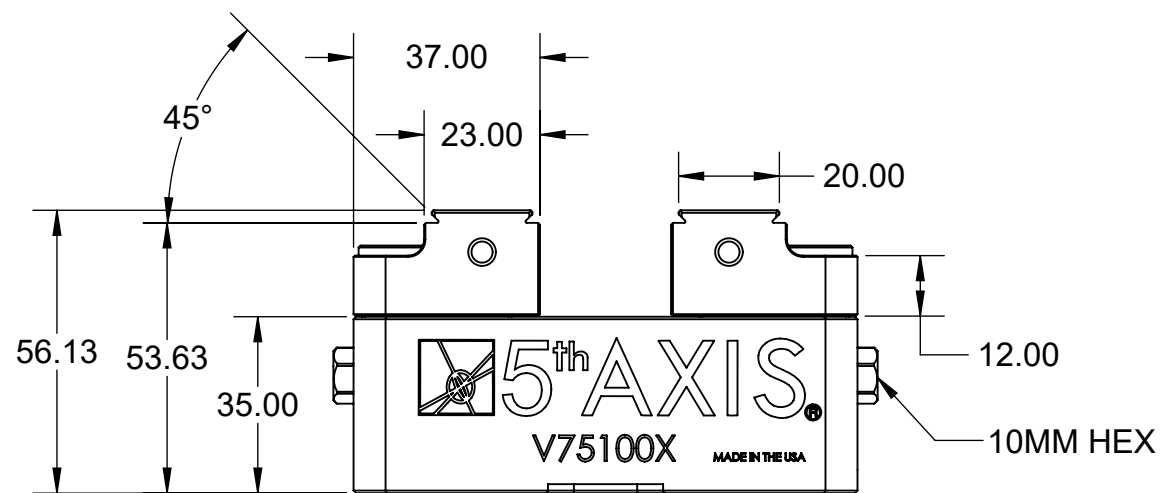

SECTION A-A

MILLIMETER <small>DRAWN IN ACCORDANCE WITH ASME Y14.5-2009</small> <small>WWW.5THAXIS.COM</small> <small>7140 ENGINEER ROAD SAN DIEGO, CA 92111</small> <small>P (858) 505-0432 F (858) 505-9344</small>	TOLERANCES <small>UNLESS OTHERWISE SPECIFIED</small> x ± 0.1 .xx ± 0.01 .x ± 0.05 .xxx ± 0.005 ANGULAR ± 0.5° <small>THIRD ANGLE PROJECTION</small>		
	DESCRIPTION SMALL SELF-CENTERING VISE		REV A
SIZE B	PART NO. V75100X	DO NOT SCALE DRAWING	SCALE 2:3
		WEIGHT:	SHEET 1 OF 3

8

7

6

5

4

3

2

1

8

7

6

5

4

3

2

1

D

D

C

C

B

B

A

A

V75100X

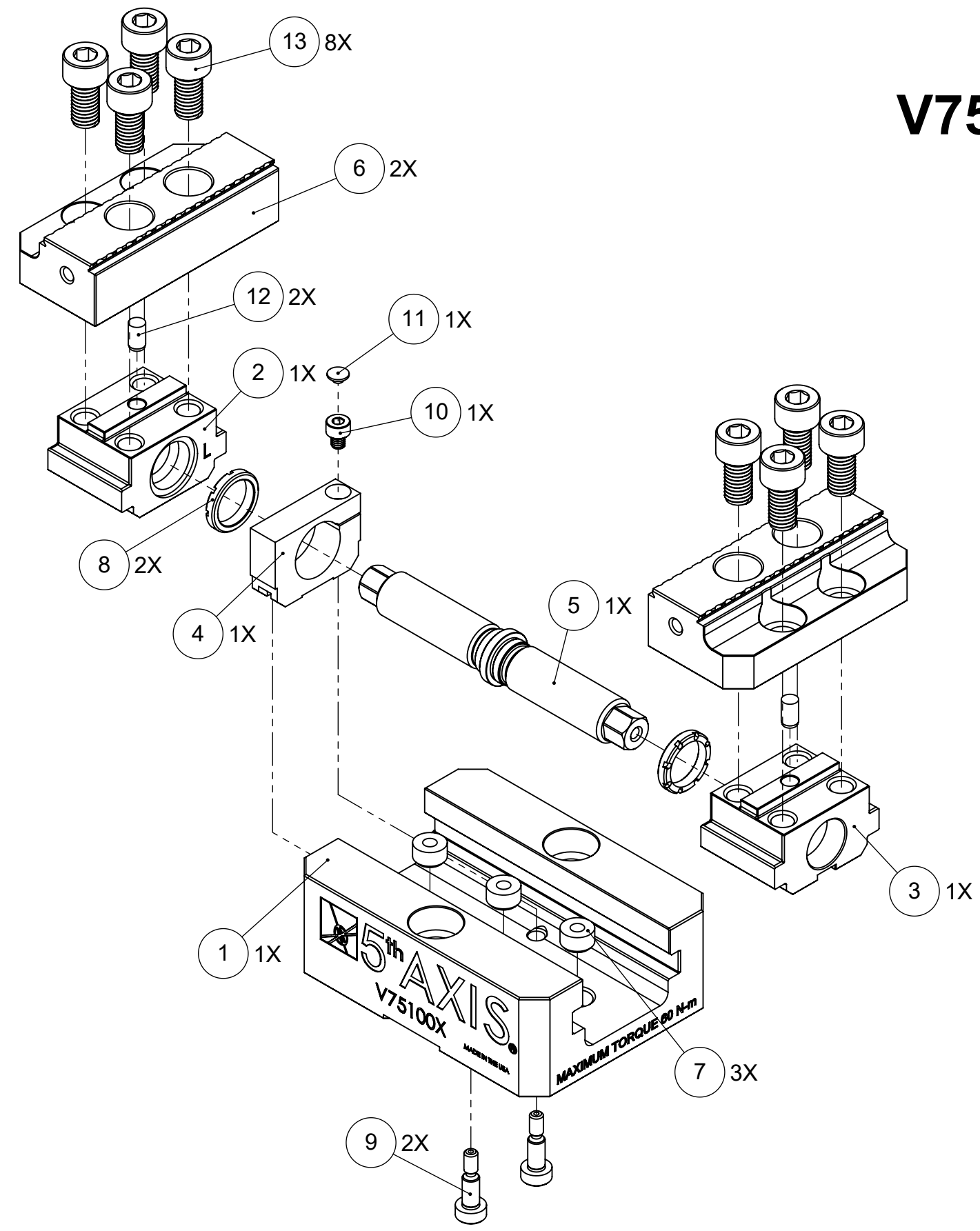

ITEM NO.	PART NUMBER	DESCRIPTION	QTY.
1	V75100-1	BASE	1
2	V75100X-2L	LEFT TRUCK	1
3	V75100X-2R	RIGHT TRUCK	1
4	V75100X-3	CENTER BLOCK	1
5	V75100-4	LEAD SCREW	1
6	V75100X-5	JAW	2
7	TIM-34	THREADED INSERT	3
8	V75100-6	CENTER BLOCK RING	2
9	SB3V	SHOULDER BOLT	2
10	91290A138	SOCKET HEAD CAP SCREW	1
11	M4C	PLASTIC PLUG	1
12	M5X10.DP	DOWEL PIN, Ø 5 X 10mm	2
13	91290A418	SOCKET HEAD CAP SCREW	8
14	ANTI-SEIZE	ANTI-SEIZE (NOT SHOWN)	1
15	LP8	LOCATING PIN (NOT SHOWN)	2
16	TS10	THUMB SCREW (NOT SHOWN)	1
17	91290A210	SOCKET HEAD CAP SCREW M8 - 1.25 X 40mm (NOT SHOWN)	2

FOR REFERENCE ONLY - NOT FOR RESALE

MILLIMETER <small>DRAWN IN ACCORDANCE WITH ASME Y14.5-2009</small>	TOLERANCES <small>UNLESS OTHERWISE SPECIFIED</small> x ± 0.1 .xx ± 0.01 .x ± 0.05 .xxx ± 0.005 ANGULAR ± 0.5° THIRD ANGLE PROJECTION		
		SMALL SELF-CENTERING VISE	
WWW.5THAXIS.COM 7140 ENGINEER ROAD SAN DIEGO, CA 92111 P (858) 505-0432 F (858) 505-9344		DESCRIPTION V75100X	REV A
DO NOT SCALE DRAWING		SCALE 2:3	WEIGHT:
		SHEET 2 OF 3	

8

7

6

5

4

3

2

1

8

7

6

5

4

3

2

1

NOTE: USING DOVETAIL ALLOWS VISE TO CLAMP LARGER PART.
BELOW CLAMPING RANGE ONLY SHOWS THE CAPABILITY OF THE GRIPPER TEETH.

V75100X

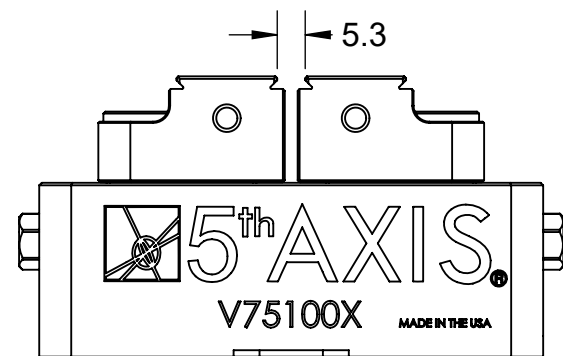

FORWARD JAWS (MINIMUM CLAMPING RANGE)

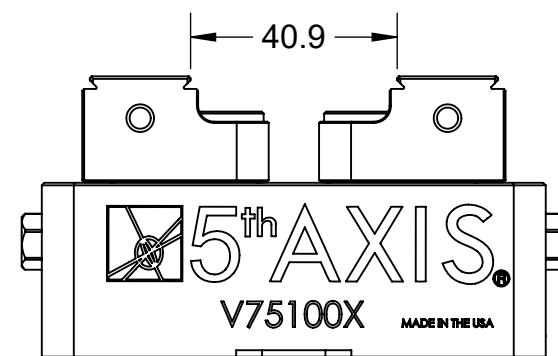

REVERSE JAWS (MINIMUM CLAMPING RANGE)

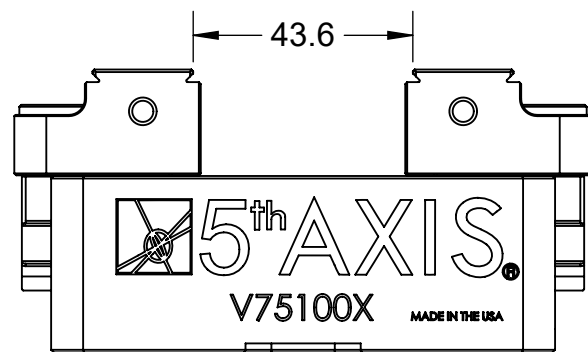

FORWARD JAWS (MAXIMUM CLAMPING RANGE)

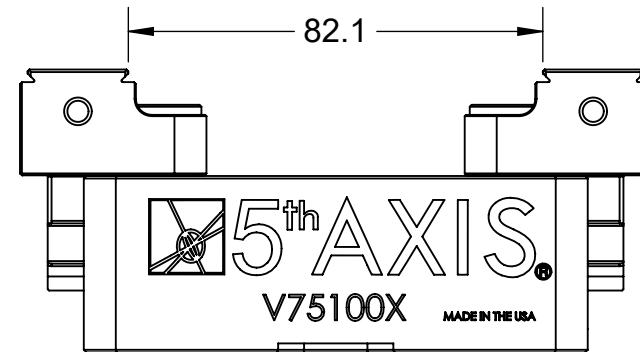

REVERSE JAWS (MAXIMUM CLAMPING RANGE)

MILLIMETER <small>DRAWN IN ACCORDANCE WITH ASME Y14.5-2009</small>	TOLERANCES <small>UNLESS OTHERWISE SPECIFIED</small>			
	<small>x ± 0.1 .xx ± 0.01 .x ± 0.05 .xxx ± 0.005 ANGULAR ± 0.5° THIRD ANGLE PROJECTION</small>			
<small>WWW.5THAXIS.COM</small>		<small>DESCRIPTION</small> SMALL SELF-CENTERING VISE		
<small>7140 ENGINEER ROAD SAN DIEGO, CA 92111</small>		<small>SIZE</small> B	<small>PART NO.</small> V75100X	<small>REV</small> A
<small>P (858) 505-0432 F (858) 505-9344</small>		<small>DO NOT SCALE DRAWING</small>		<small>SCALE 2:3</small>
		<small>WEIGHT:</small>		<small>SHEET 3 OF 3</small>

8

7

6

5

4

3

2

1