

Tuscan MC Series 4 Jaw Machine Chuck Specification

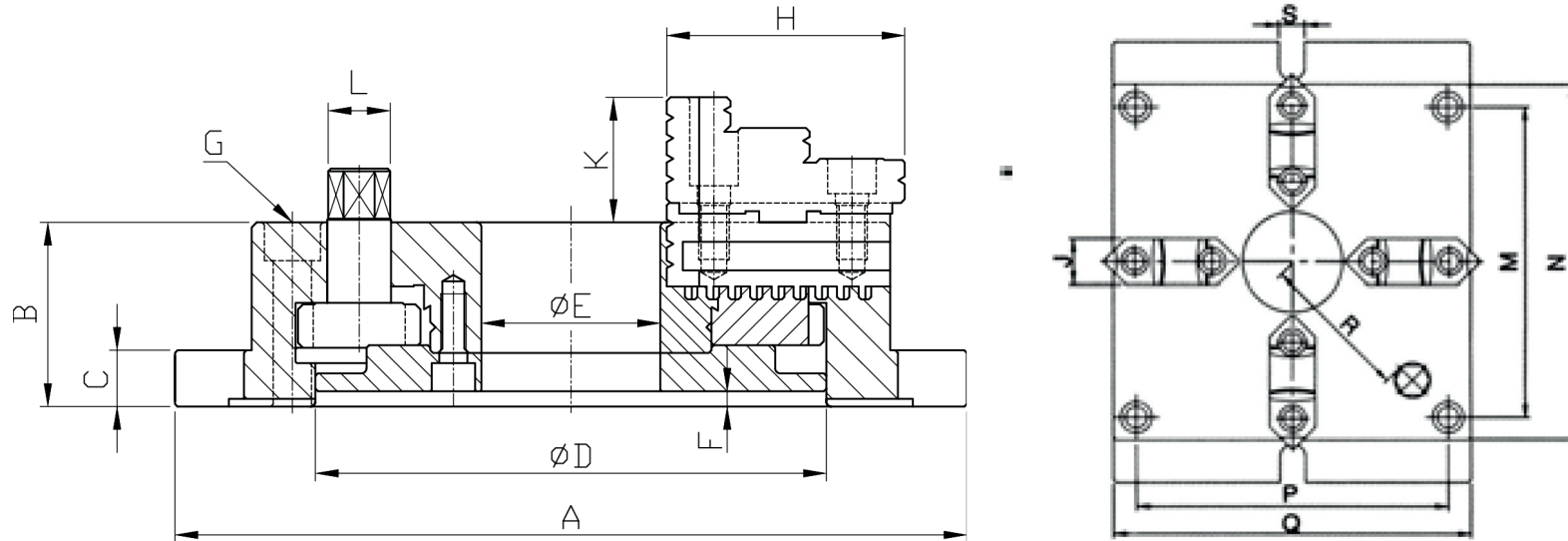

Part No	A (mm)	B (mm)	C (mm)	D (mm)	E (mm)	F (mm)	G (mm)	H (mm)	J (mm)	K (mm)	L (mm)	M (mm)	N (mm)	P (mm)	M (mm)	Weight (Kg)	OD Clamping	ID Clamping
MC-08	250	65	20	160	55	6	40M12X1.75P	82	28	43	17	174	200	174	200	18.6	Ø5 - 162	Ø62 - 162
MC-10	310	72	22	200	70	6	4-M14X2P	93	32	50	21	218	250	218	250	31.6	Ø6 - 200	Ø72 - 200
MC-12	380	85	25	260	100	7	4-M16X2P	118	40	56	23	274	310	274	310	56.6	Ø10 - 265	Ø90 - 265