

# Tuscan 3DKT Series 3 Jaw Manual Scroll Chuck Specification

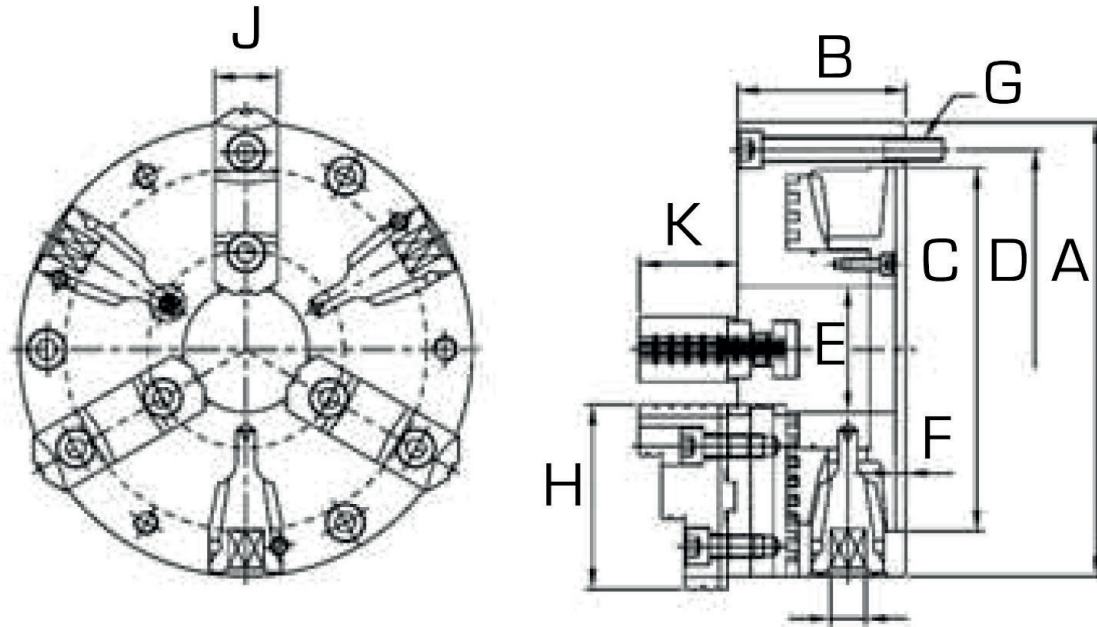

Part No	A (mm)	B (mm)	C (mm)	D (mm)	E (mm)	F (mm)	G	H (mm)	J (mm)	K (mm)	L (mm)	Max Speed rpm (min-1)	OD Clamping	ID Clamping
3DKT-05	125	58.5	95	108	32	4	3-M8x1.25P	57	24	36	8	4800	Ø3 - Ø121	Ø44 - Ø120
3DKT-06	160	65	125	140	42	4	3-M10x1.5P	68	26	38.5	10	4200	Ø8 - Ø169	Ø50 - Ø158
3DKT-08	200	74.5	160	176	55	4	3-M10x1.5P	82	28	43	11	3500	Ø8 - Ø206	Ø58 - Ø191
3DKT-10	250	83	200	224	76	5	3-M12x1.75P	102	35	54.5	12	2600	Ø12 - Ø266	Ø77 - Ø250
3DKT-12	315	94	260	286	103	5	3-M16x2P	117.5	40	56.5	14	2200	Ø15 - Ø340	Ø85 - Ø313