

TAO16.PD

caratteristiche/features



peso/weight



11,7 kg

rotazione/rotation



prestazioni/performance

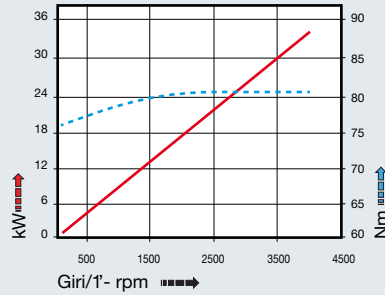

CONO SHANK	size	A	B	H	
				standard	optional
DIN69871 *	-	223,5	35	-	-
	45			80	110
ANSIB5.50 *	-	227,5	-	65	-
	50			80	110
* BT	-	231,5	45	65	-
	50			80	110
HSK	-	232,5	46	-	-
	80			80	110
CAPTO	-	227,5	-	-	-
	C8			80	110
KM	-	223,5	-	-	-
	80			80	110
DIN2080	-	-	-	-	-
	-	-	-	-	-
NMTB	-	-	-	-	-
	-	-	-	-	-

tipi mandrino disponibili / available spindle types

- 2** Albero portafresa Milling shaft **3** Weldon Whistle-Notch **4** DIN69893-HSK
- Ø16-Ø22-Ø27** **Ø16** **HSK40**

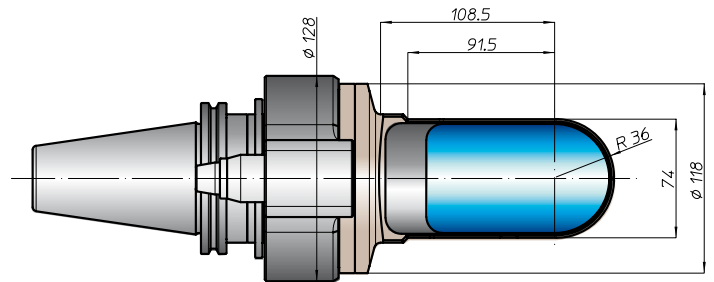
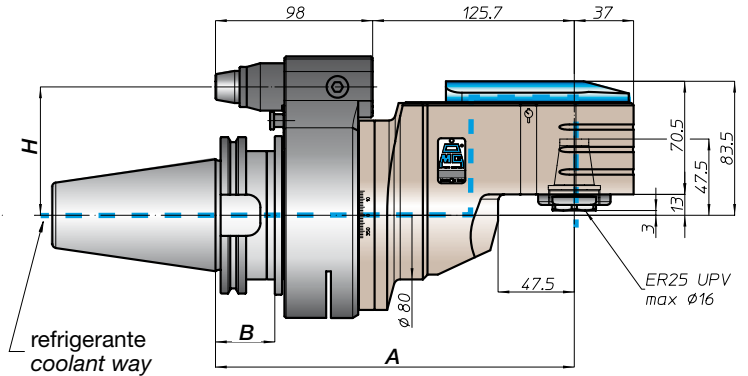
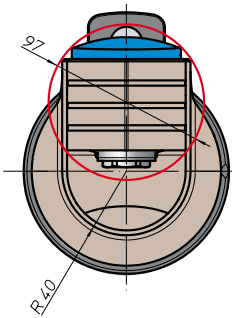

* Option: Dual Contact

BAH
 TA.CP
 TA
 MO
 HT
 VH
 TSI/TSX
 T
 MT-TC-TC3
 Accessori
 Accessories
 Appendice tecnica
 Technical supplement

