



teste ad angolo  
angle heads

**HEAVY  
DUTY**

Un prodotto fondamentale che grazie alla riduzione dei piazzamenti in lavorazione, vanta un contributo prezioso per l'aumento della produttività necessaria per competere su tutti i mercati: parliamo della Testa ad Angolo, da considerare come parte integrante del parco utensili della macchina.

- **Esperienza** - E' dall'inizio degli anni '60 che O.M.G. crea prodotti. L'esperienza non si acquista, si acquisisce. La realizzazione fin dai primi anni di prodotti speciali ha formato le competenze per lo sviluppo di una gamma di Teste ad Angolo articolata e performante, idonea alla clientela più esigente che crede negli investimenti per conquistare nuovi mercati.
- **Tradizione** - Il termine "qualità" viene spesso citato, ma non significa soltanto utilizzare macchine utensili tecnologicamente avanzate per ottenere lavorazioni precise. La qualità è il risultato di esperienze pratiche, di calcoli matematici, di sfide vinte e perse ma comunque accettate, di cui fare grande tesoro.
- **Innovazione** - Le Teste ad Angolo Speciali di ultima generazione offrono prestazioni superiori a tutti gli standard e condizionano spesso la produzione fino al punto da divenire indispensabili nel completamento del processo produttivo. Da queste OMG continua a trarne grande beneficio e soddisfazione con soluzioni tecniche poi riproposte sulle Teste ad Angolo Standard a catalogo.
- **Modularità** - Indispensabile oggi la flessibilità produttiva, ancora maggiore negli investimenti. In questa ottica gli elementi modulari delle Teste ad Angolo consentono di ridurre i costi ed aumentare i benefici.
- **Personalizzazione** - Se l'ampia gamma di Teste ad Angolo standard non risponde all'esigenza specifica, siamo pronti a progettare e costruire il prodotto speciale, forti dell'esperienza di centinaia di soluzioni operative volte alle più svariate attività produttive.

*An ultimate product that gives a valuable contribution to the productivity increase by reducing the management of the pieces to be machined, necessary condition to compete in the markets all over the world: we are talking about the Angle Heads, to be considered an integrant part of the machine tools range.*

- **Experience** - O.M.G. engineers its products since the beginning of the '60's. The experience cannot be bought but it is acquired. Since that time the achievement of special products gave us the expertise to develop a range of Angle Heads very broad and performing, suitable to the most demanding customers believing in investments to gain new market shares.
- **Tradition** - The word "quality" is often mentioned, but it does not mean just to use technologically advanced machine tools to get accurate machining. The quality is the result of practical experiences, of mathematical calculations, of won and lost challenges, anyway accepted, which are treasured.
- **Innovation** - The last generation Special Angle Heads offers performances much higher than all standards, and they often affect the production cycles until becoming indispensable when completing production stages. O.M.G. keeps getting beneficial results from his special range which is also reflected into the standard Angle Heads range.
- **Modularity** - Nowadays the productivity flexibility is mandatory, and even more in the investments. Towards this goal the O.M.G. Angle Heads modular system allows cost reductions and to increase profits.
- **Customization** - And if the wide range of standard Angle Heads will not meet your requirements, we are ready to engineer and to manufacture a new Special Angle Head product, always supported by our experience of hundreds of solutions done for many different industrial activities.

# Panoramica prodotti

## Product overview



### TAR

Piccole per piccoli spazi.

*Tiny for narrow spaces.*

Pagina/Page: 4-8



### TA

Lavorazione singola di foratura e fresatura.

*Drilling and milling machining.*

Pagina/Page: 4-16



### TA... D

Input refrigerante attraverso lo stop-block e uscita attraverso il centro utensile.

*Input coolant from stop-block, and output through tool spindle.*

Pagina/Page: 4-36



### TAO

Mandrino offset, lavorazione in spazi ristretti ed ottima performance in fresatura.

*Offset spindle, machining in narrow spaces, and excellent results in milling operations.*

Pagina/Page: 4-46



### TAF

Mandrino fisso, angolo su richiesta del cliente.

*Fixed spindle with custom angle.*

Pagina/Page: 4-70

### Simboli/Icons



Capacità di foratura  
*Drilling capacity*



Pressione  
*Pressure*



Maschiatura  
*Tapping*



Peso  
*Weight*



Rapporto entrata/uscita  
*Ratio input/output*



Carico assiale  
*Axial load*



N° max giri in uscita  
*Max output RPM*



# Panoramica prodotti

## Product overview



### TA... L

Versione allungata per lavorazioni singole di foratura e fresatura.

*Length stretched version for drilling and milling single machining operations.*

Pagina/Page: 4-9



### TA... 2P

Due mandrini contrapposti di 180°.

*180° two opposed spindles.*

Pagina/Page: 4-30



### TAO... PD

Mandrino offset, input refrigerante attraverso il centro cono, uscita attraverso centro utensili con pressione 70 bar.

*Offset spindle, input coolant through machine taper, output through tool spindle at 70 bar pressure.*

Pagina/Page: 4-47



### TAV

Mandrino variabile  $\pm 90^\circ$ .

*$\pm 90^\circ$  adjustable spindle.*

Pagina/Page: 4-56

### Simboli/Icons



Peso con cono 40  
*Weight with size 40 shank*



Dual Contact



Peso con cono 50  
*Weight with size 50 shank*



Rotazione in ingresso  
*Input rotation*



Rotazione in uscita  
*Output rotation*

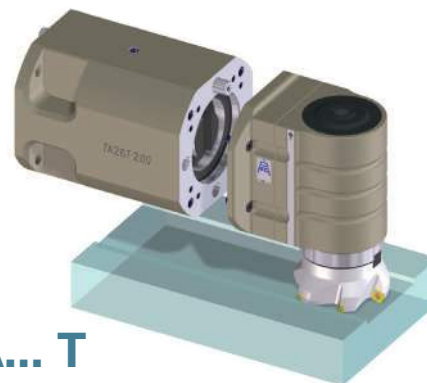

### TA... T

Connessione alla macchina tramite flangia.

*To be connected to the machine by flange.*

Pagina/Page: 4-76

# Sistema modulare per applicazioni flessibili

## Modular system for flexible application



- 1** Testa ad angolo con presa utensile ER standard, oppure vedi tipi Mandrino.  
*Angle Head with standard ER tool connection, or check other spindle types.*
- 2** Antirotante standard “senza gioco”, oppure su specifico design per la vostra macchina utensile.  
*No backlash standard torque arm, or under specific design for your machine tool.*
- 3** Coni macchina standard o speciali su richiesta.  
*Standard or on-demand machine tapers.*

**Modularità Coni** – Sono disponibili tutti i tipi di cono macchina, da sostituire tramite un esclusivo accoppiamento di precisione che crea un sistema rigido pari ai cono integrali, ma con i pregi dell’intercambiabilità.

**Modularità Antirotanti** – esistono fondamentalmente tre dimensioni unificate di interasse tra il centro cono ed il centro perno antirotante: 65 mm per i cono grandezza 40, 80 mm per i cono grandezza 50 ed in alcuni casi anche 110 mm. Sono disponibili tutte le dimensioni e sostituire il gruppo antirotante è una operazione banale.

**Taper modularity** - All the different machine tapers are available, and can be replaced with an exclusive precision coupling system generating a rigid system equal to integral tapers, but with additional interchangeability quality.

**Torque arm modularity** - Essentially three unified dimensions between taper and torque-arm centers exist: 65 mm for the taper size 40, 80 mm for the taper size 50 and also 110 mm in some cases. All sizes are available and torque-arm replacement is very simple.



# Prese utensili - tipi mandrino

## Clamping systems and spindle types



1 DIN6388-ER



2 Albero portafrese  
Milling shaft



3 Weldon  
Whistle-Notch



4 DIN69893-HSK



5 COROMANT  
CAPTO®



6 ABS  
Licenza KOMET®



7 ISO-DIN2079  
NMTB-BT

# Refrigerante utensile

## Coolant tool



STANDARD



TA... PD  
max 10 bar



TAO... PD  
max 70 bar



TAF... PD  
max 70 bar



TAV... PD  
max 70 bar

**Il circuito refrigerante è standard** - Tutte le teste sono provviste di canalizzazione interna, che parte dal perno dell'antiro-tante e termina sull'ugello vicino all'utensile, senza alcun costo aggiuntivo.

**Refrigerante da cono macchina** - La costruzione offset delle Teste ad Angolo serie TAO consente il montaggio di tenute ad alta pressione affidabili nel tempo ed isolate dalle parti vitali della Testa ad Angolo, per un sicuro utilizzo di utensili con passaggio refrigerante interno.

**Coolant system is standard** - All our Angle Heads are supplied with an internal channel system, which starts from the torque-arm pin and ends on the nozzles next to the tool, without additional cost.

**Coolant system from machine taper** - The offset construction of the TAO Angle Head series allows to fit high pressure seals which are time reliable and isolated from the vital parts of the Angle Heads, for a safe usage of tools with internal coolant transit.



# Antirotante Torque arm



STANDARD



TriBlock®



QuadBlock®



Studiato e realizzato su  
specifica richiesta.  
*Customized design according  
to your application.*

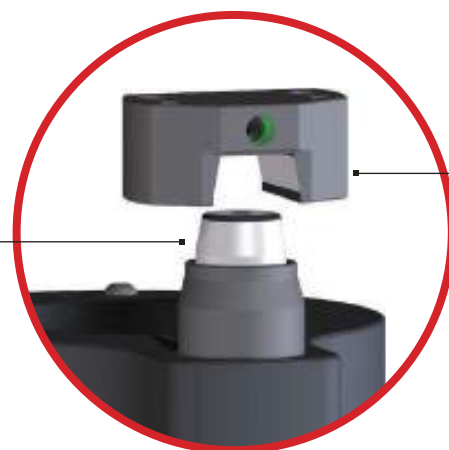

Stop-block

Perno conico  
Conical pin

**Prestazioni superiori** - L'antirotante standard permette di cambiare la testa in automatico. Il sistema di accoppiamento fra perno conico regolabile assialmente e lo stop-block con sede a "V", permette di annullare la tolleranza tra le parti creando un sistema rigido, senza giochi. Evidenti sono i vantaggi: maggiore durata degli utensili, maggiore durata dei cuscinetti, risparmi in termini di manutenzione con conseguente riduzione dei costi.

**Massima stabilità** - I sistemi antirotanti **TriBlock** e **QuadBlock** di O.M.G. con perni regolabili permettono di contrastare al meglio le spinte radiali e assiali con la possibilità di affrontare in sicurezza lavorazioni di fresatura o finitura fino a ora mai effettuate con le teste ad angolo, destinate inizialmente a diversi piazzamenti pezzo.

**Higher performances** - The standard torque arm allows an automatic change of the head. The coupling system between the conical pin, which can be axial adjusted, and the "V"-housing of the stop-block, allows to cancel any tolerance between those parts generating a rigid and backlash free system. The advantages are evident: longer life of tools, longer life of bearings, maintenance savings with consequent cost reductions.

**Maximum stability** - The O.M.G. **TriBlock** and **QuadBlock** torque arm systems with adjustable pin allow to oppose both radial and axial thrusts at their best, with the possibility of milling or finishing with total security, which was not possible until nowadays because requiring several changes of placement of the piece to be machined.



# Connessione alla macchina tramite flangia

## *Machine connection by flange*

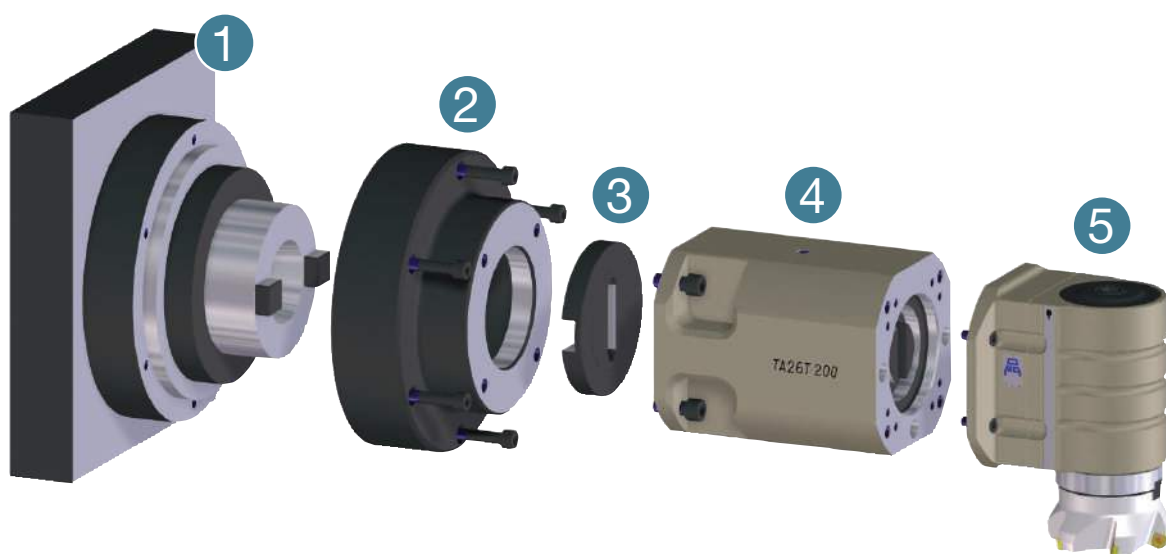

1	Macchina	<i>Machine</i>
2	Flangia di connessione	<i>Connection flange</i>
3	Giunto ISO 40/50	<i>Driving joint ISO 40/50</i>
4	Estensione	<i>Extension</i>
5	Testa ad angolo TA... T	<i>Angle head TA... T</i>

testa ad angolo - angle head

# TAR03.P

caratteristiche/features

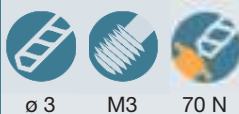

ø 3 M3 70 N



1-1.2308 8000

peso/weight



6,7 kg



9,1 kg

rotazione/rotation



input



output

prestazioni/performance

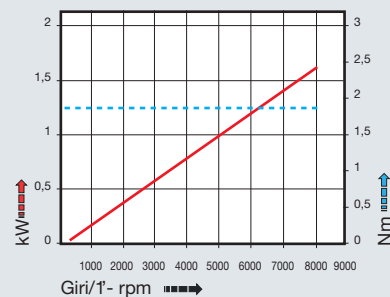

Giri/T-rpm

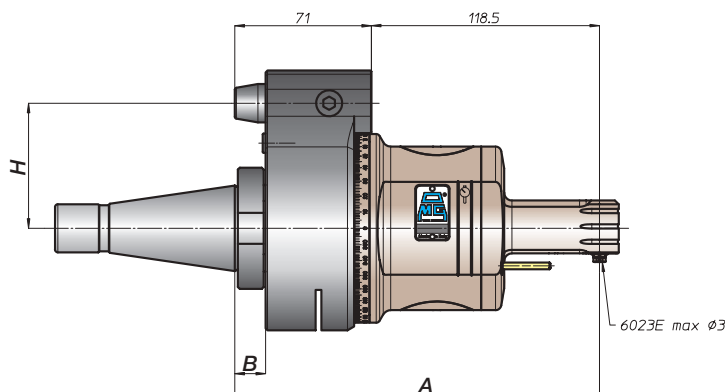
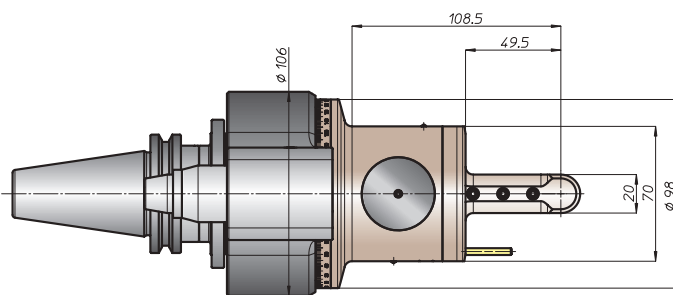
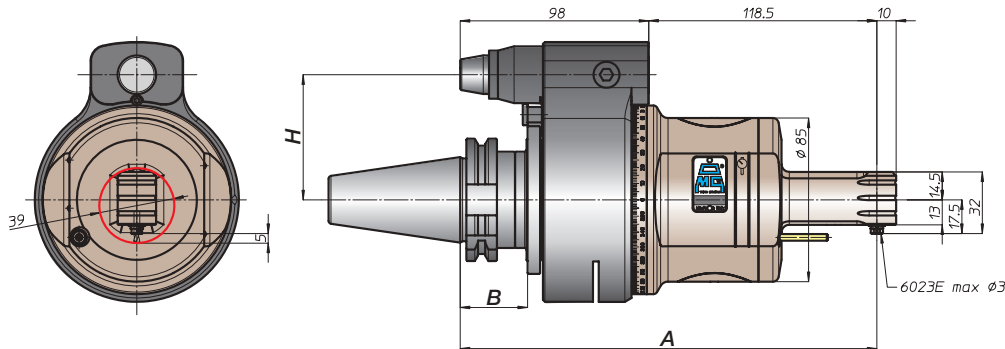

CONO SHANK	size	H			
		A	B	standard	optional
* DING9871	30			65	-
	40			80	110
	45			80	110
	50	216,5	35	80	110
* ANSIB5.50 CAT	40			65	-
	50			80	110
* BT	40			65	
	50	224,5	45	80	110
HSK	63		44	65	
	80	225,5		80	110
	100		46	80	110
ISO26623 CAPTO	C5			65	
	C6		39		
	C8	220,5		80	110
KM	63			65	
	80	216,5		80	110
	100			80	110
DIN2080	-	186,5	13	65	-
	40				
	-	189,5	16	80	110
ANSIB5.18 NMTB	40	186,5	13	65	-
	50	189,5	16	80	110

\* Option: Dual Contact

FH  
BAH  
TA.CP  
TA  
MO  
HT  
VH  
TSI/TSX  
T  
MT-TC-TC3  
Accessori  
Accessories  
Appendice tecnica  
Technical supplement  
4-8





# TAR03.PL

caratteristiche/features



peso/weight

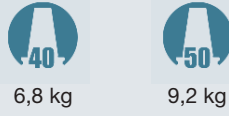

rotazione/rotation



prestazioni/performance

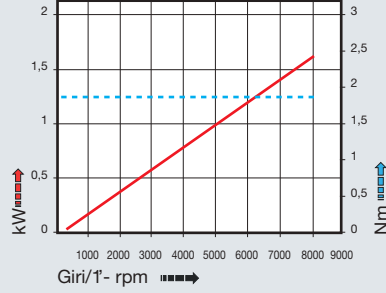

CONO SHANK	size	A	B	H	
				standard	optional
* DING69871	30	247,5	35	65	-
	40			80	110
	45			80	110
	50			80	110
* ANSIB5.50 CAT	40	255,5	45	65	-
	50			80	110
* BT	40	255,5	45	65	-
	50			80	110
DING69893 HSK	63	256,5	44	65	-
	80		46	80	110
	100		46	80	110
ISO26623 CAPTO	C5	251,5	39	65	-
	C6			80	110
	C8			80	110
KM	63	247,5	39	65	-
	80			80	110
	100			80	110
DIN2080	-	217,5	13	65	-
	40	220,5	16	80	110
	50			80	110
ANSIB5.18 NMTB	40	217,5	13	65	-
	50	220,5	16	80	110

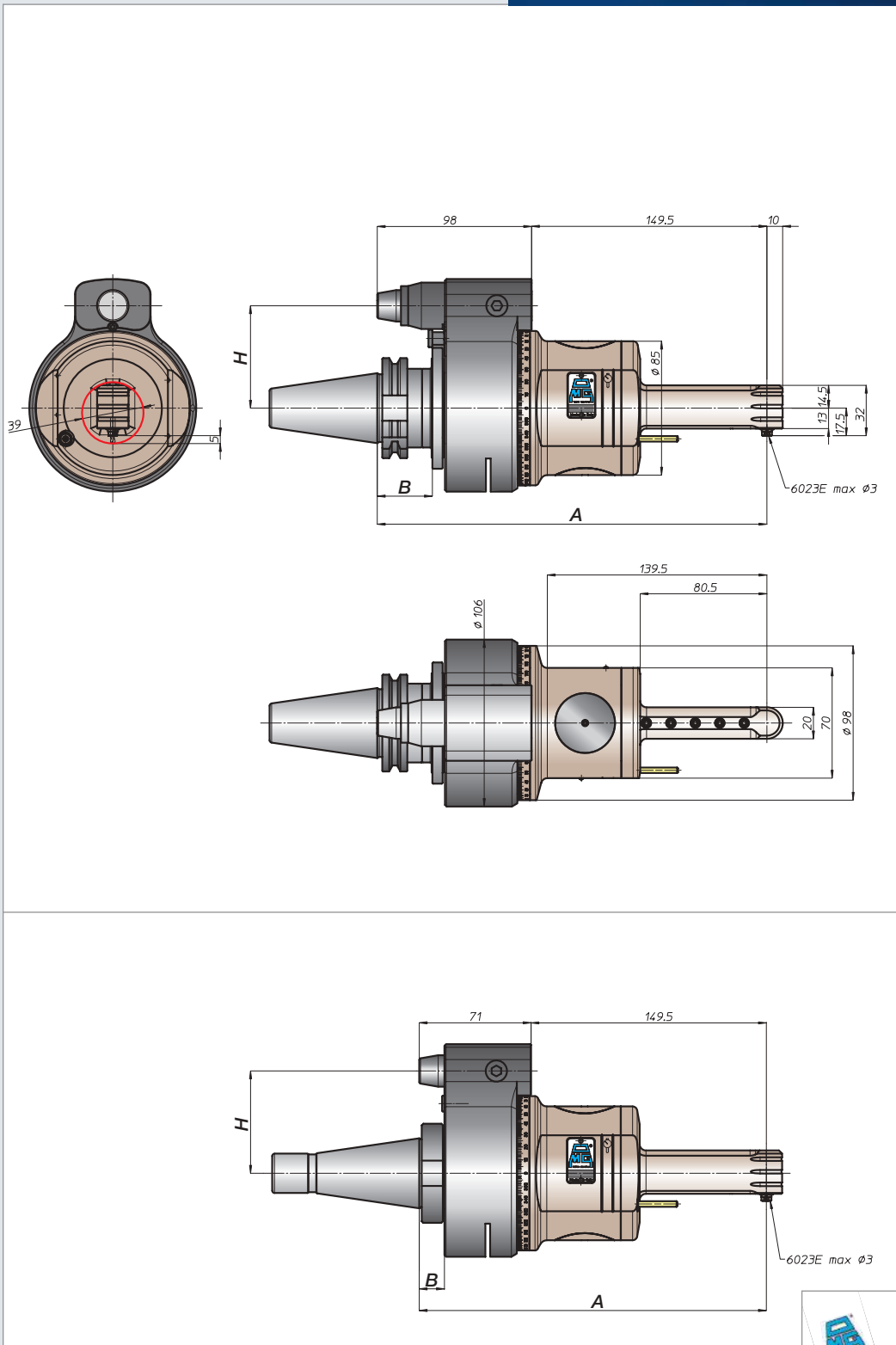

\* Option: Dual Contact



FH  
 BAH  
 TA.CP  
 TA  
 MO  
 HT  
 VH  
 TSI/TSX  
 T  
 MT-TC-TC3  
 Accessori  
 Accessories  
 Appendice tecnica  
 Technical supplement  
 4-9

testa ad angolo - angle head

# TAR04.P



caratteristiche/features

$\phi$  4    M3    120 N

1-1    8000

peso/weight

7 kg    9,4 kg

rotazione/rotation

input    output

prestazioni/performance

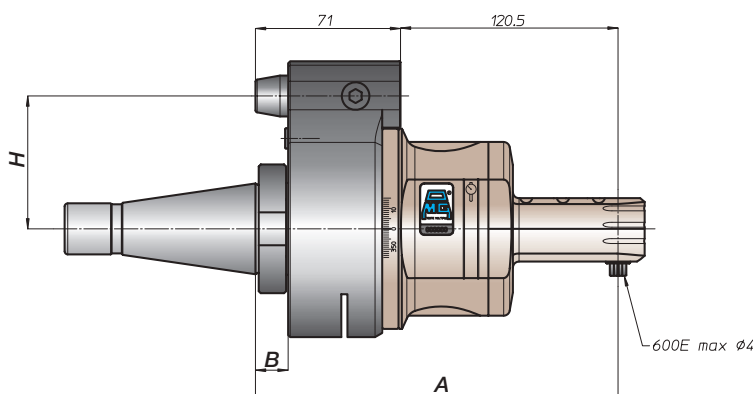
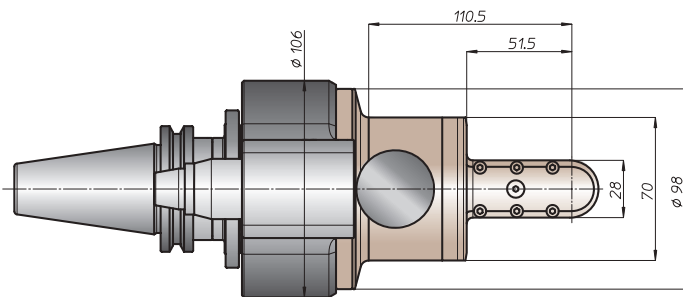
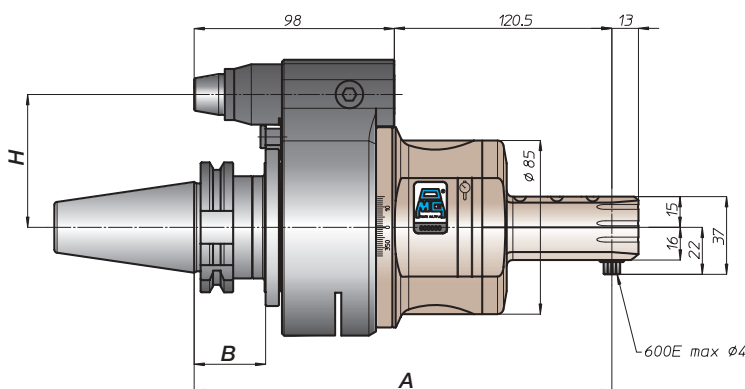
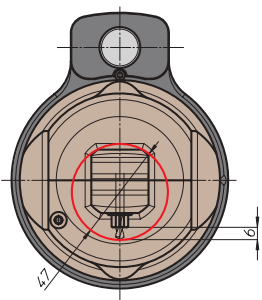
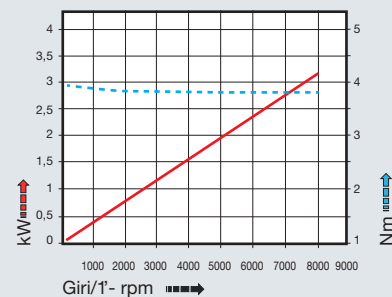

CONO SHANK	size	H			
		A	B	standard	optional
* DING9871	30			65	-
	40			80	110
	45			80	110
	50	218,5	35	80	110
* ANSIB5.50 CAT	40			65	-
	50			80	110
* BT	40			65	
	50	226,5	45	80	110
DING9893	63		44	65	
	80	227,5		80	110
	100		46	80	110
ISO28623	C5			65	
	C6	222,5	39		
	C8			80	110
KM	63			65	
	80	218,5		80	110
	100			80	110
DIN2080	-	188,5	13	65	-
	40			65	-
	-	191,5	16	80	110
ANSIB5.18	40	188,5	13	65	-
	50	191,5	16	80	110

\* Option: Dual Contact



# TAR04.PL

caratteristiche/features



peso/weight

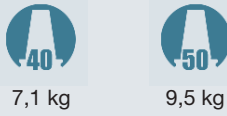

rotazione/rotation



prestazioni/performance

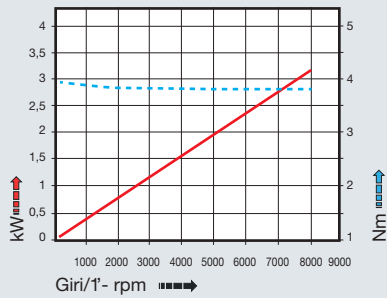

CONO SHANK	size	A	B	H	
				standard	optional
* DING9871	30	257	35	65	-
	40			80	110
	45			80	110
	50			80	110
* ANSIB5.50 CAT	40	257	35	65	-
	50			80	110
* BT	40	265	45	65	-
	50			80	110
DING9893 HSK	63	266	44	65	-
	80			80	110
	100			80	110
ISO26623 CAPTO	C5	261	39	65	-
	C6			80	110
	C8			80	110
KM	63	257	35	65	-
	80			80	110
	100			80	110
DIN2080	-	227	13	65	-
	40			80	110
	50			80	110
ANSIB5.18 NMTB	40	230	16	65	-
	50			80	110

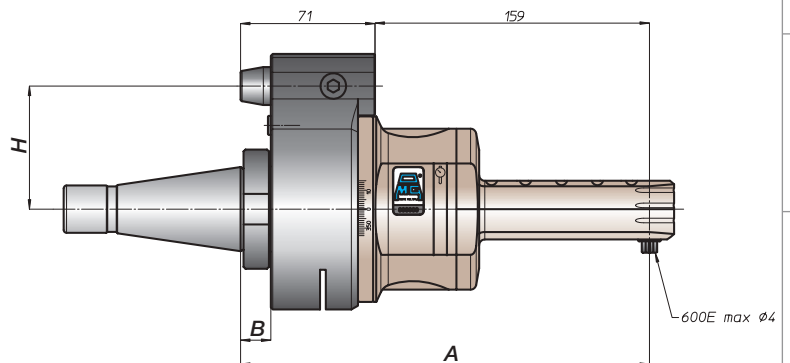
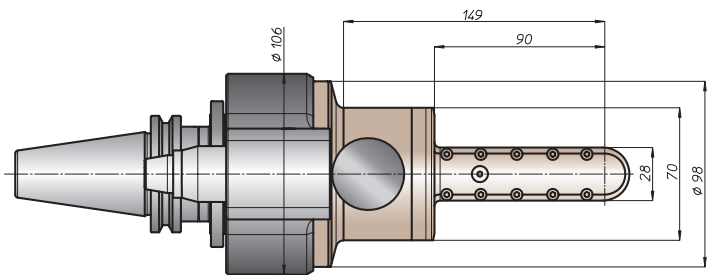
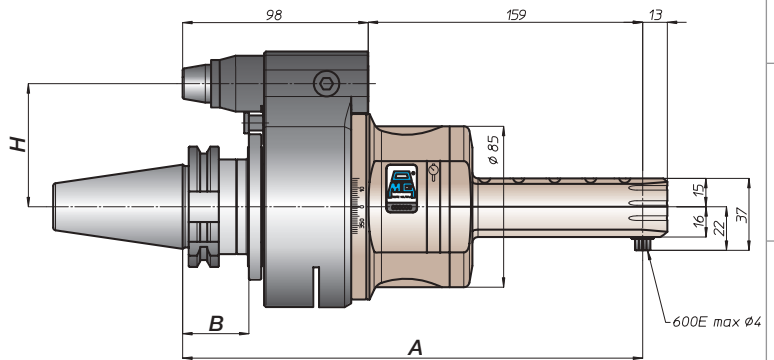
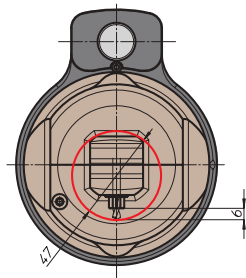

\* Option: Dual Contact



FH  
BAH  
TA.CP  
TA  
MO  
HT  
VH  
TSI/TSX  
T  
MT-TC-TC3  
Accessori  
Accessories  
Appendice tecnica  
Technical supplement

testa ad angolo - angle head

# TAR06.P



caratteristiche/features

$\phi 6$    
 M5   
 150 N  
 1-1   
 8000

peso/weight

40  
 7,2 kg   
 50  
 9,6 kg

rotazione/rotation

IN   
 OUT  
 input    output

prestazioni/performance

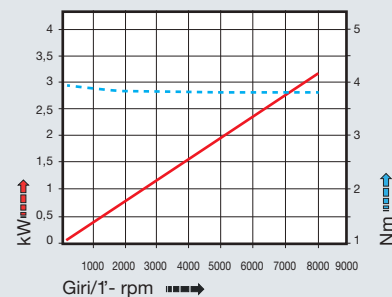

tipi mandrino disponibili / available spindle types

3 Weldon Whistle-Notch  
 $\phi 6$

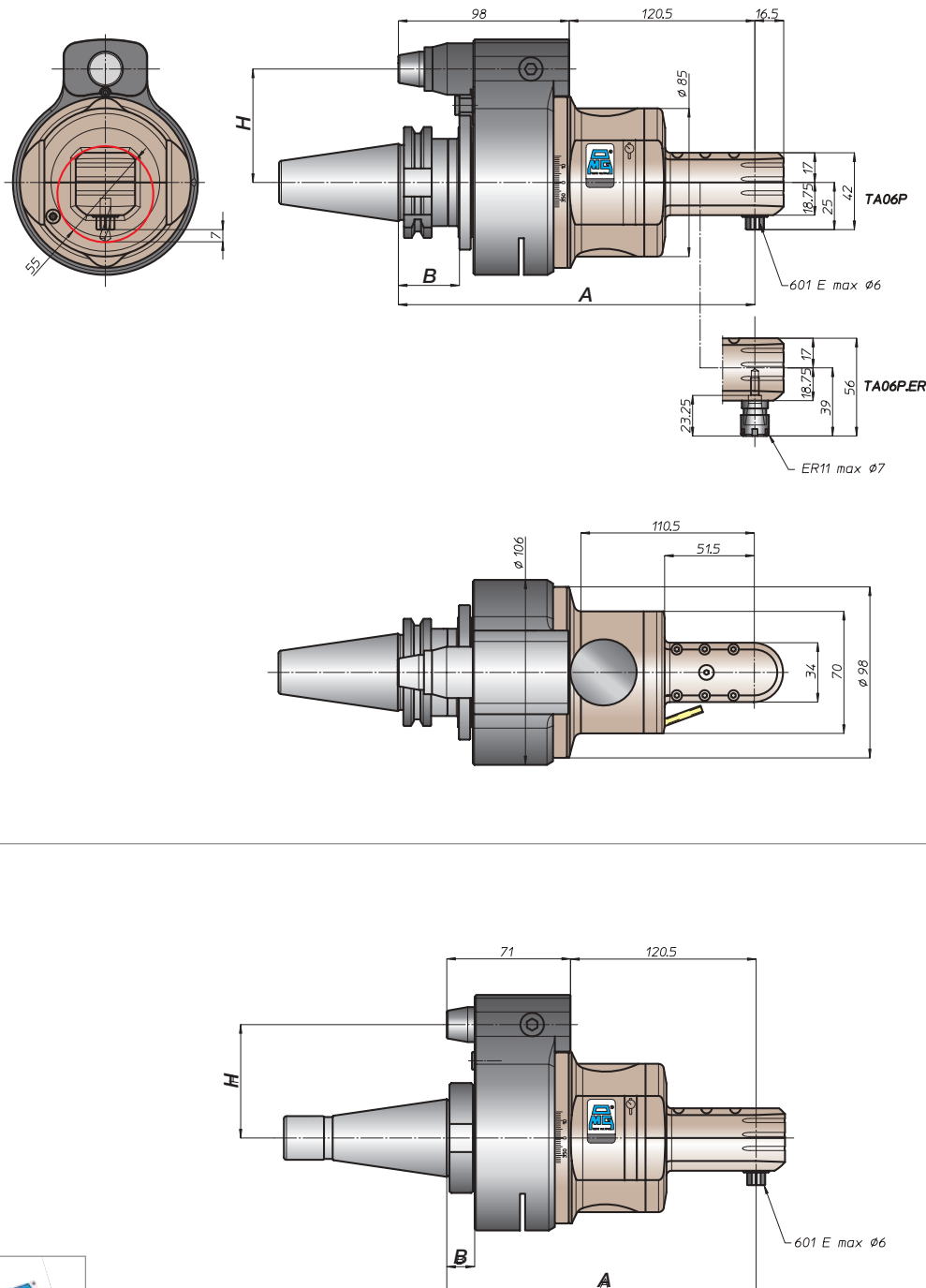

CONO SHANK	size	H			
		A	B	standard	optional
* DIN9871	30			65	-
	40			80	110
	45			80	110
	50	218,5	35	80	110
* CAT ANSIB5.50	40			65	-
	50			80	110
* BT	40			65	
	50	226,5	45	80	110
HSK DIN9893	63		44	65	
	80	227,5		80	110
	100		46	80	110
CAPTO ISO26623	C5			65	
	C6	222,5	39		
	C8			80	110
KM	63			65	
	80	218,5		80	110
	100			80	110
DIN2080	-	188,5	13	65	-
	40				
	-	191,5	16	80	110
ANSIB5.18 NMTB	40	188,5	13	65	-
	50	191,5	16	80	110

\* Option: Dual Contact



# TAR06.PL

caratteristiche/features



peso/weight

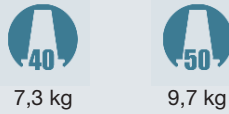

rotazione/rotation



prestazioni/performance

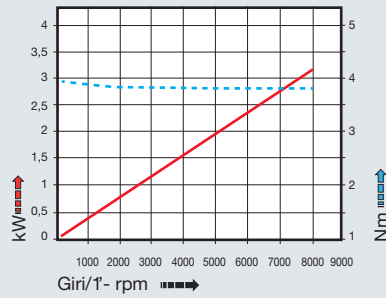

CONO SHANK	size	A	B	H	
				standard	optional
DIN9871 *	30	257	35	65	-
	40			80	110
	45			80	110
	50			80	110
ANSIB5.50 *	40	265	45	65	-
	50			80	110
* BT	40	265	45	65	-
	50			80	110
DIN9893 HSK	63	266	44	65	-
	80		46	80	110
	100		46	80	110
ISO26623 CAPTO	C5	261	39	65	-
	C6			80	110
	C8			80	110
KM	63	257	45	65	-
	80			80	110
	100			80	110
DIN2080	-	227	13	65	-
	40			80	110
	50			80	110
ANSIB5.18 NMTB	40	230	16	65	-
	50			80	110

tipi mandrino disponibili / available spindle types

**3** Weldon Whistle-Notch  
 $\varnothing 6$

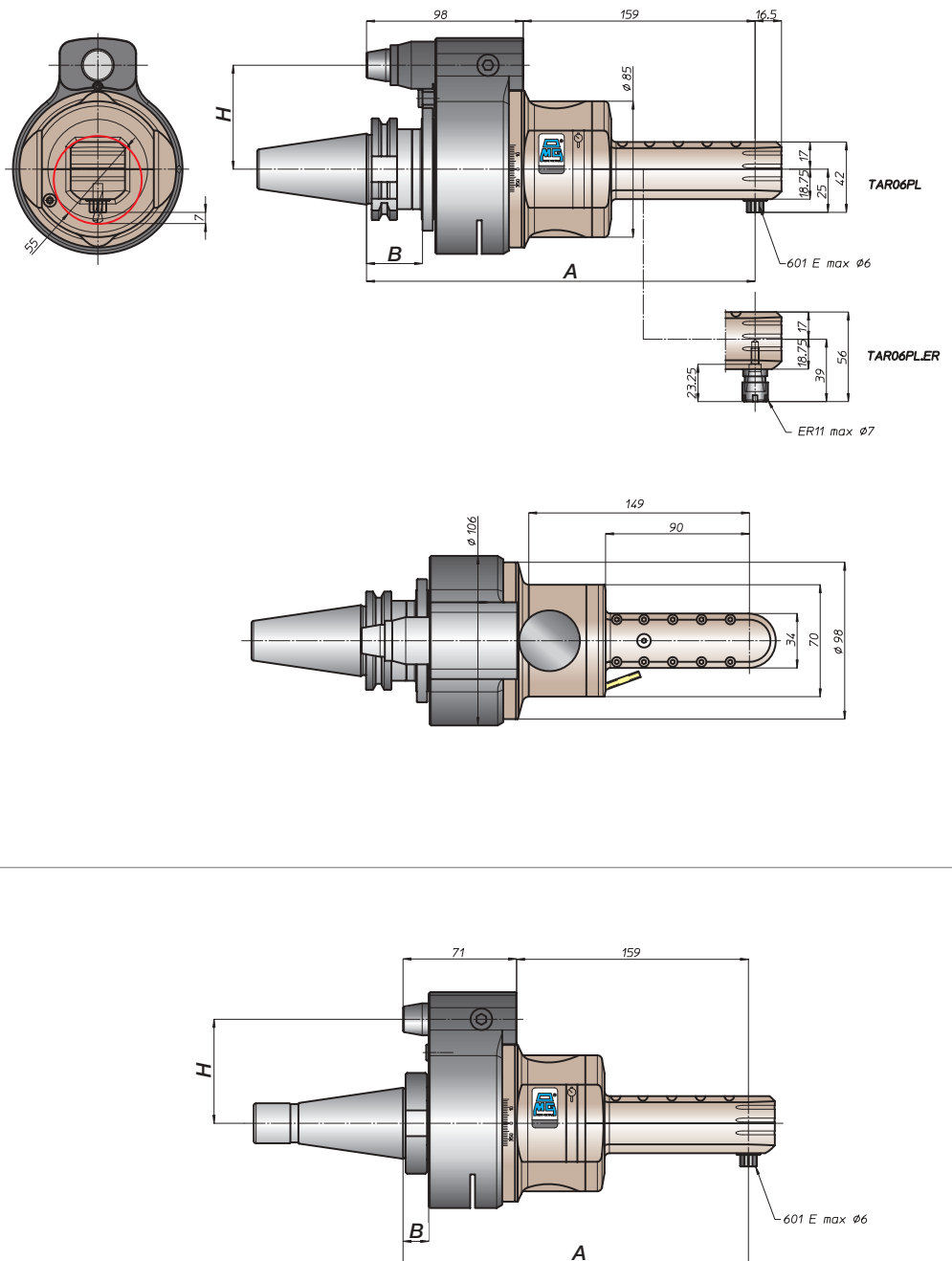

\* Option: Dual Contact



FH  
 BAH  
 TA.CP  
 TA  
 MO  
 HT  
 VH  
 TSI/TSX  
 T  
 MT-TC-TC3  
 Accessori  
 Accessories  
 Appendice tecnica  
 Technical supplement

testa ad angolo - angle head

# TAR10.P



caratteristiche/features



  
 ø 10    M8    430 N  

  
 1-1    6000

peso/weight

  
 7 kg    9 kg

rotazione/rotation

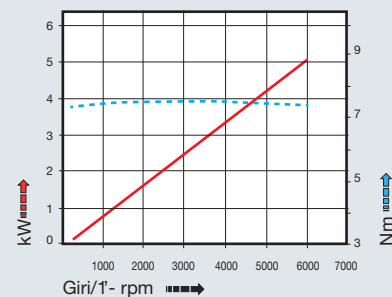

  
 input    output

prestazioni/performance

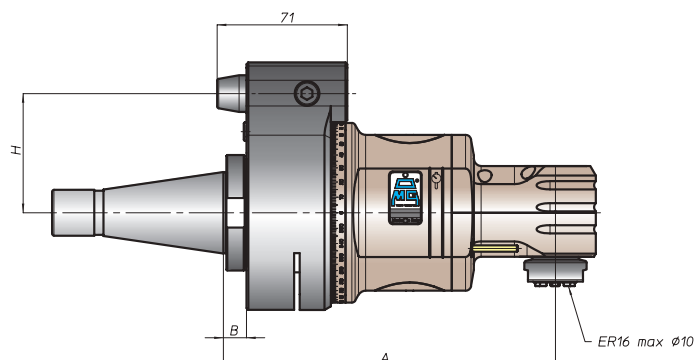
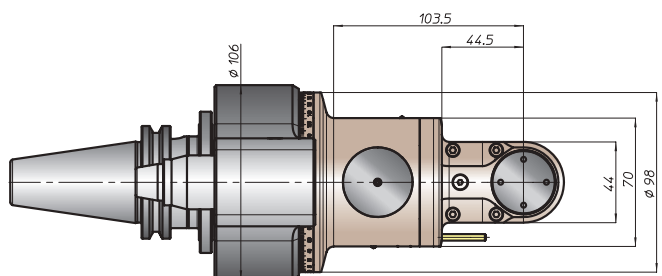
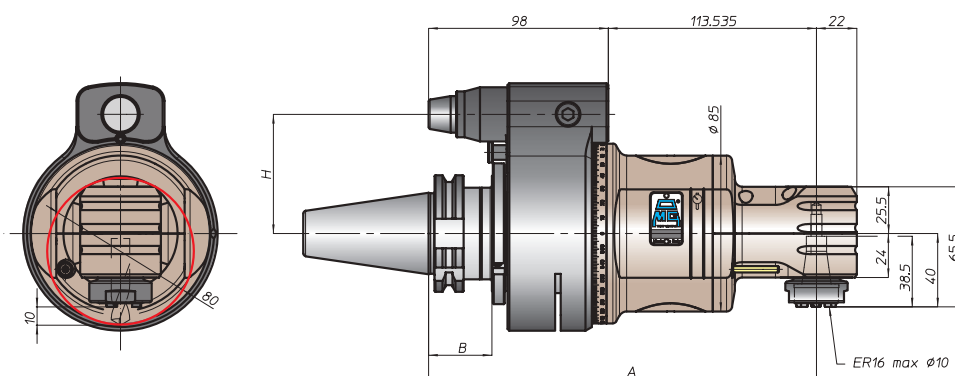

tipi mandrino disponibili / available spindle types

3 Weldon Whistle-Notch  
Ø12



CONO SHANK	size	H			
		A	B	standard	optional
* DING9871	-			65	-
	40	211,5	35	80	110
	45			80	110
* CAT ANSIB5.50	40	211,5	35	65	-
	50			80	110
* BT	40	211,5	35	65	-
	50			80	110
HSK DING9893	63	220,5	44	65	-
	80			80	110
	100			46	80
CAPTO ISO28623	C5	215,5	39	65	-
	C6			80	110
	C8			80	110
KM	63	211,5	35	65	-
	80			80	110
	100			80	110
DIN2080	-	181,5	13	65	-
	40			80	110
	50			16	80
ANSIB5.18 NMTB	40	181,5	13	65	-
	50			16	80

\* Option: Dual Contact



# TAR10.PL

caratteristiche/features



peso/weight

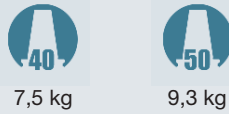

rotazione/rotation



prestazioni/performance

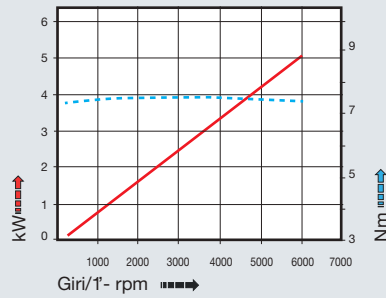

CONO SHANK	size	A	B	H	
				standard	optional
DING9871	40	243	35	65	-
	45			80	110
	50			80	110
ANSIB5.50 CAT	40	243	35	65	-
	50			80	110
BT	40	251	45	65	-
	50			80	110
HSK DING9893	63	252	44	65	-
	80			80	110
	100			80	110
CAPTO ISO26623	C5	247	39	65	-
	C6			80	110
	C8			80	110
KM	63	243	35	65	-
	80			80	110
	100			80	110
DIN2080	40	213	13	65	-
	50	216	16	80	110
	50	216	16	80	110
NMTB ANSIB5.18	40	213	13	65	-
	50	216	16	80	110

tipi mandrino disponibili / available spindle types

3 Weldon Whistle-Notch  
Ø12

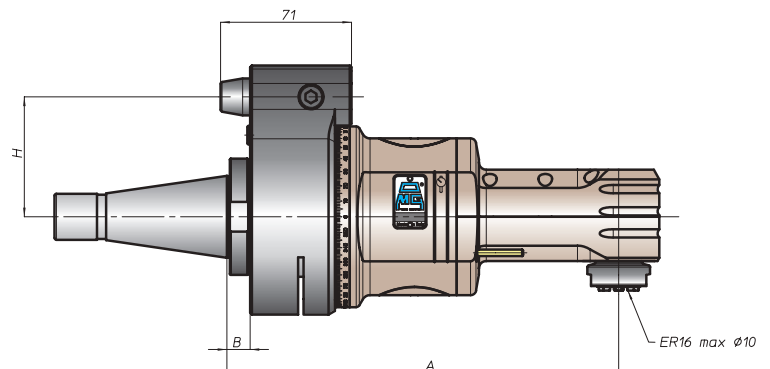
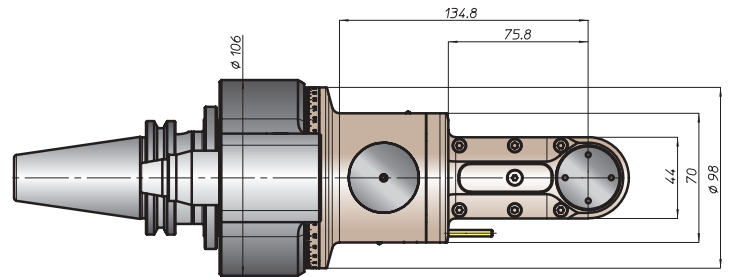
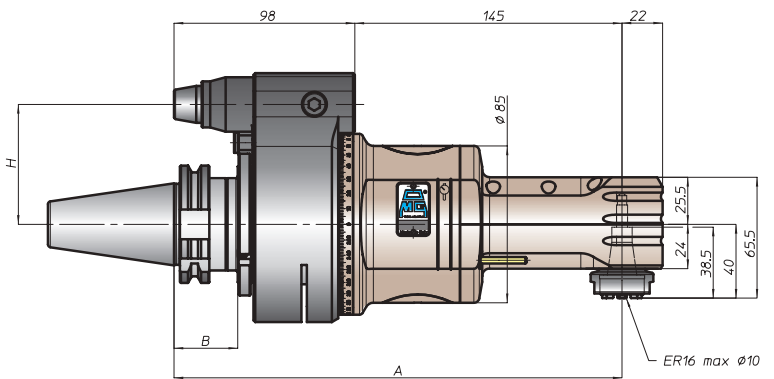
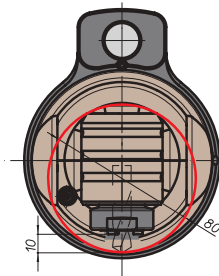

★ Option: Dual Contact



FH  
BAH  
TA.CP  
TA  
MO  
HT  
VH  
TSI/TSX  
T  
MT-TC-TC3  
Accessori  
Accessories  
Appendice tecnica  
Technical supplement

testa ad angolo - angle head

# TA07.P



caratteristiche/features

$\phi$  7    M6    180 N

1-1    10000

peso/weight

40    50

5,5 kg    7,5 kg

rotazione/rotation

IN    OUT

input    output

prestazioni/performance

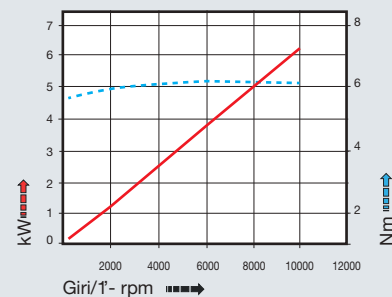

tipi mandrino disponibili / available spindle types

**3** Weldon Whistle-Notch  
Ø8-Ø10

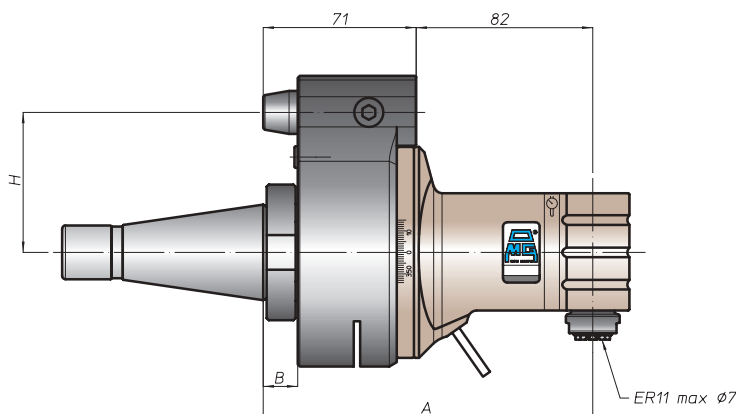
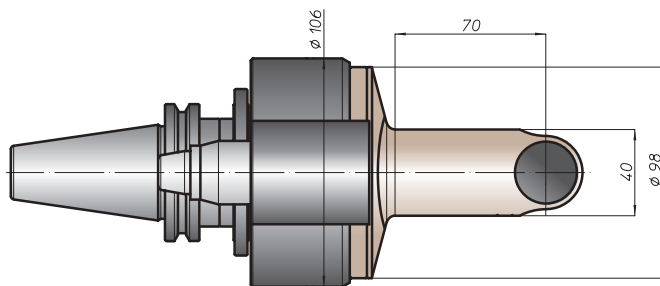
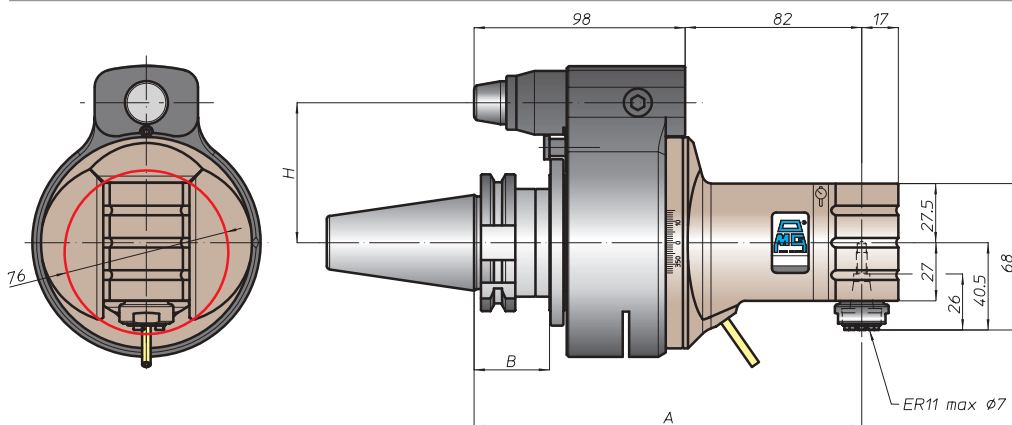

CONO SHANK	size	H			
		A	B	standard	optional
* DING9871	30			65	-
	40			80	110
	45			80	110
	50	180	35	80	110
* ANSIB5.50 CAT	40			65	-
	50			80	110
* BT	40			65	
	50	188	45	80	110
HSK DING9893	63		44	65	
	80	189		80	110
	100		46	80	110
CAPTO ISO28623	C5			65	
	C6	184	39		
	C8			80	110
KM	63			65	
	80	180		80	110
	100			80	110
DIN2080	-	150	13	65	-
	40			80	110
ANSIB5.18 NMTB	-	153	16	80	110
	50			80	110
ANSIB5.18	40	150	13	65	-
	50	153	16	80	110

\* Option: Dual Contact





# TA07.PL



caratteristiche/features



peso/weight

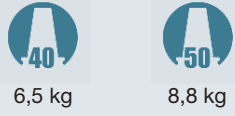

rotazione/rotation



prestazioni/performance

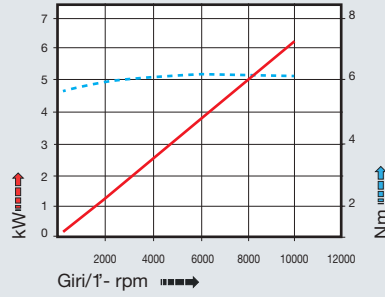

CONO SHANK	size	A	B	H	
				standard	optional
* DING9871	-	250	35	65	-
	40			80	110
	45			80	110
* ANSIB5.50 CAT	40	250	35	65	-
	50			80	110
* BT	40	258	45	65	-
	50			80	110
DING9893 HSK	63	259	44	65	-
	80			80	110
	100			80	110
ISO26623 CAPTO	C5	254	39	65	-
	C6			80	110
	C8			80	110
KM	63	250	35	65	-
	80			80	110
	100			80	110
DIN2080	-	220	13	65	-
	40			80	110
	50			80	110
ANSIB5.18 NMTB	40	223	16	65	-
	50			80	110

tipi mandrino disponibili / available spindle types

3 Weldon Whistle-Notch  
Ø8-Ø10

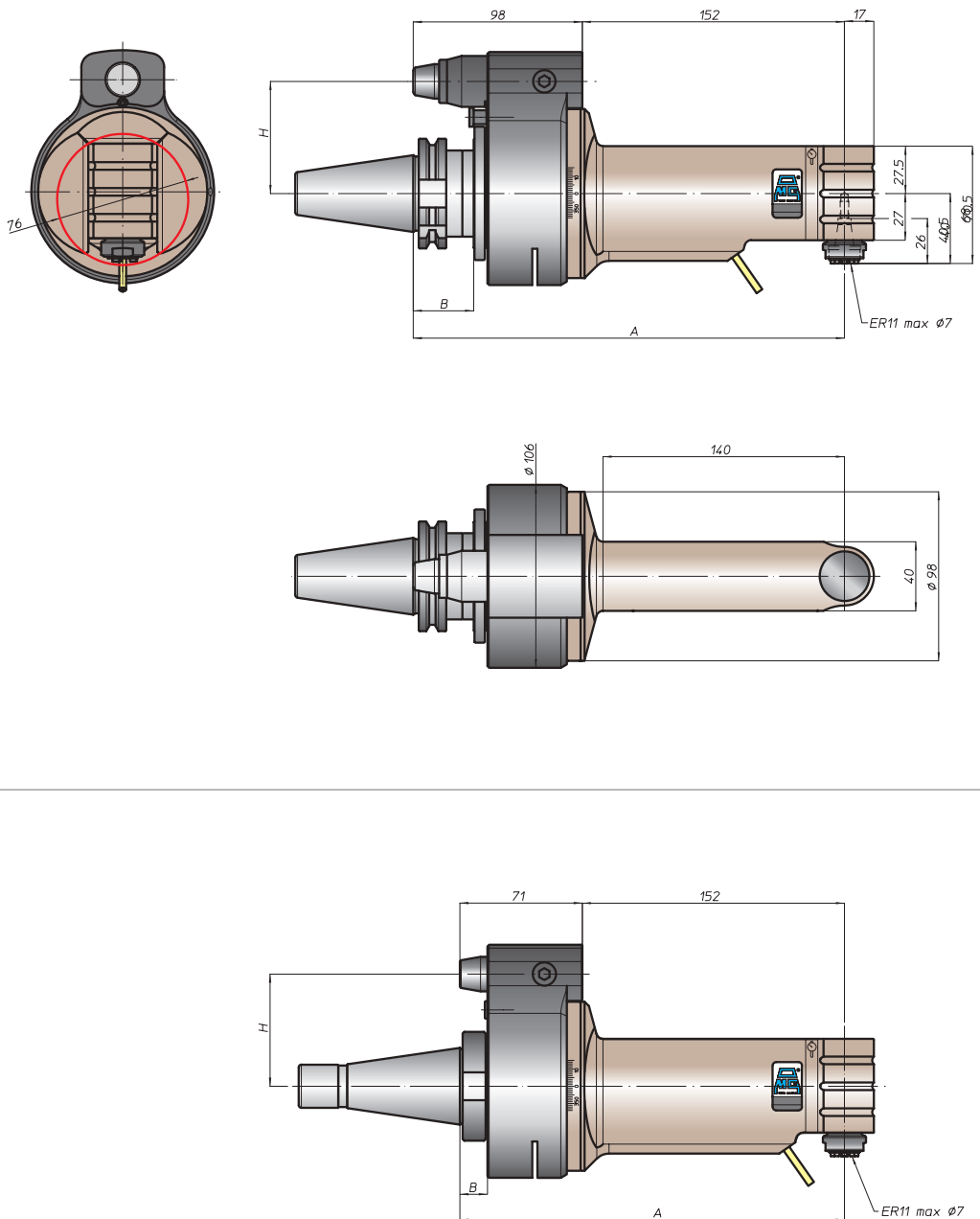

\* Option: Dual Contact



FH  
BAH  
TA.CP  
TA  
MO  
HT  
VH  
TSI/TSX  
T  
MT-TC-TC3  
Accessori  
Accessories  
Appendice tecnica  
Technical supplement

testa ad angolo - angle head

# TA10.P





caratteristiche/features



  
 ø 10    M8    400 N  

  
 1-1    10000

peso/weight

  
 5,8 kg    8 kg

rotazione/rotation

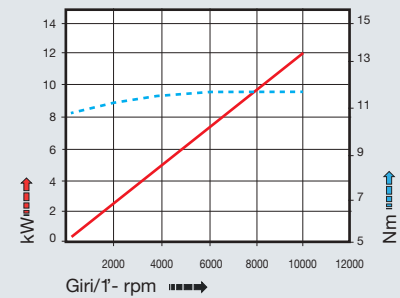

  
 input    output

prestazioni/performance

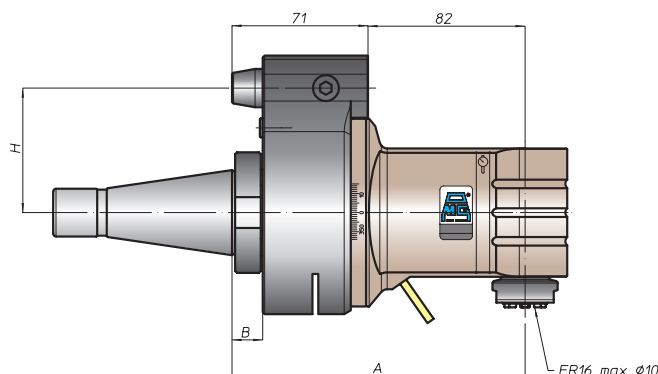
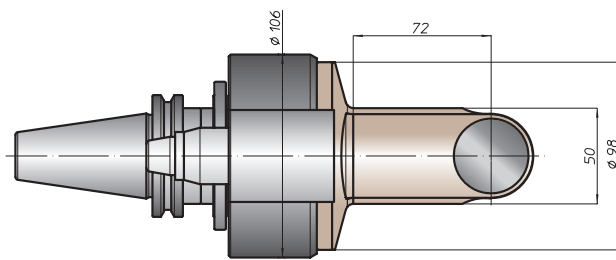
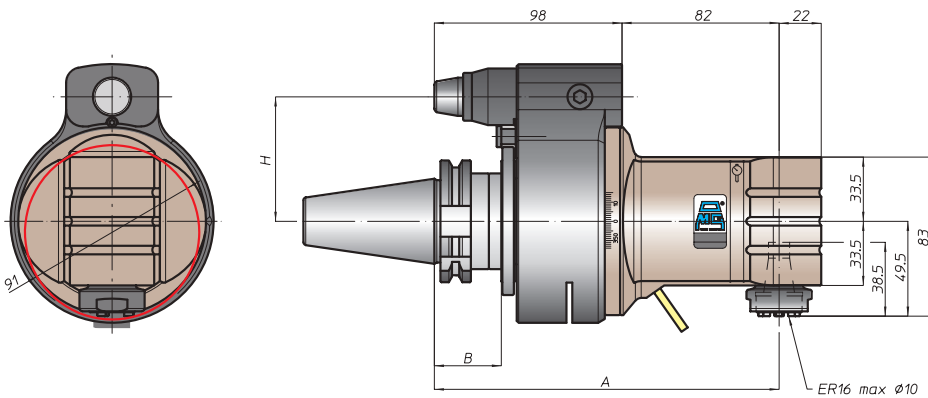

tipi mandrino disponibili / available spindle types

- 1** DIN6388-ER    **2** Albero portafresse Milling shaft    **3** Weldon Whistle-Notch
- ER20**                      **Ø16**                              **Ø10**



CONO SHANK	size	H			
		A	B	standard	optional
* DIN69871	30	180	35	65	-
	40			80	110
	45			80	110
	50			80	110
* ANSIB5.50 CAT	40	188	45	65	-
	50			80	110
* BT	40	188	45	65	-
	50			80	110
HSK DIN69893	63	189	46	65	-
	80			80	110
	100			80	110
CAPTO ISO28623	C5	184	39	65	-
	C6			80	110
	C8			80	110
KM	63	180	-	65	-
	80			80	110
	100			80	110
DIN2080	40	150	13	65	-
	50	153	16	80	110
ANSIB5.18 NMTB	40	150	13	65	-
	50	153	16	80	110

\* Option: Dual Contact



# TA10.PL

caratteristiche/features



peso/weight

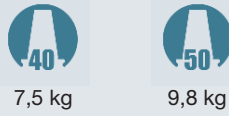

rotazione/rotation



prestazioni/performance

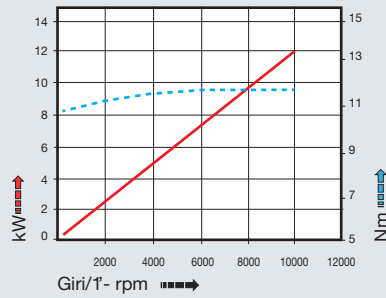

CONO SHANK	size	A	B	H	
				standard	optional
* DING9871	-	250	35	65	-
	40			80	110
	45			80	110
* ANSIB5.50 CAT	40	258	45	65	-
	50			80	110
* BT	40	258	45	65	-
	50			80	110
DING9893 HSK	63	259	44	65	-
	80		46	80	110
	100		46	80	110
ISO26623 CAPTO	C5	254	39	65	-
	C6			80	110
	C8			80	110
KM	63	250	45	65	-
	80			80	110
	100			80	110
DIN2080	-	220	13	65	-
	40			80	110
	50			80	110
ANSIB5.18 NMTB	40	223	16	65	-
	50			80	110

tipi mandrino disponibili / available spindle types

- 1** DIN6388-ER    **ER20**
- 2** Albero portafresa Milling shaft    **Ø16**
- 3** Weldon Whistle-Notch    **Ø10**

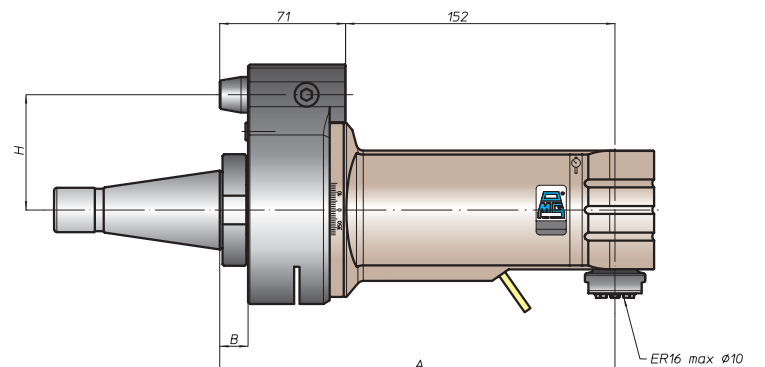
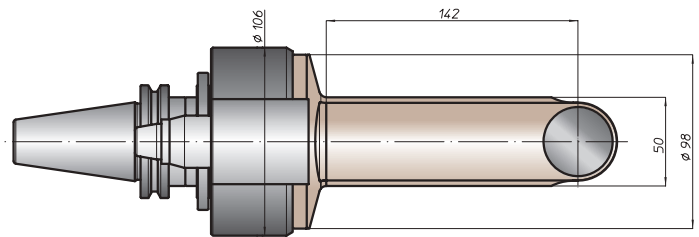
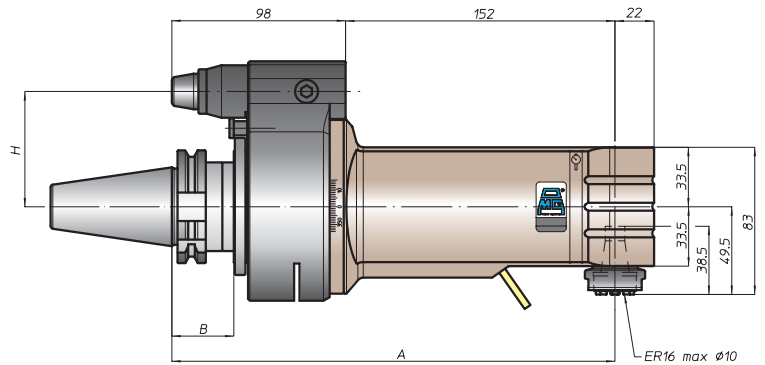
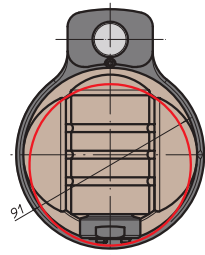

\* Option: Dual Contact



FH  
 BAH  
 TA.CP  
 TA  
 MO  
 HT  
 VH  
 TSI/TSX  
 T  
 MT-TC-TC3  
 Accessori  
 Accessories  
 Appendice tecnica  
 Technical supplement

testa ad angolo - angle head

# TA13.P



caratteristiche/features

ø 13    M10    810 N

1-1    8000

peso/weight

6,5 kg    9 kg

rotazione/rotation

input    output

prestazioni/performance

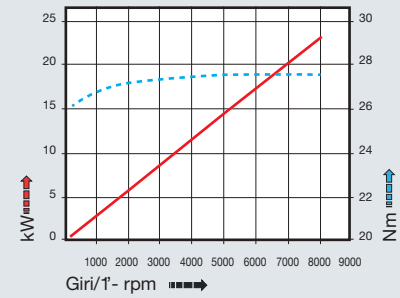

tipi mandrino disponibili / available spindle types

- 1** DIN6388-ER ER25
- 2** Albero portafrese Milling Shaft Ø16-Ø22
- 3** Weldon Whistle-Notch Ø16

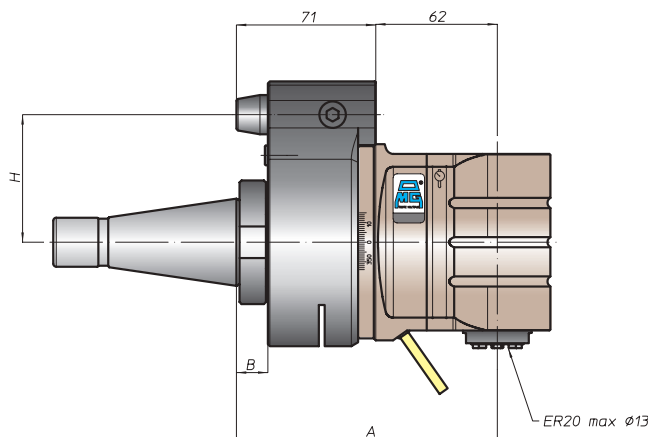
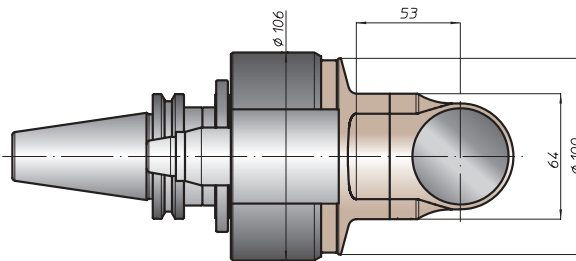
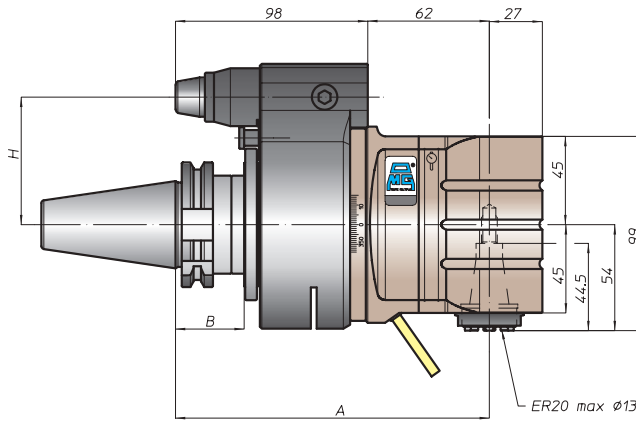
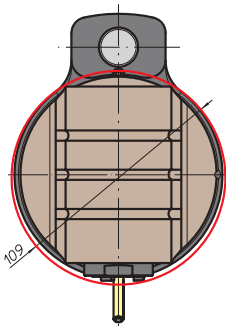

CONO SHANK	size	H			
		A	B	standard	optional
* DIN69871	-			65	-
	40			80	110
	45	160	35	80	110
* CAT ANSIB5.50	40			65	-
	50			80	110
* BT	40			65	
	50	168	45	80	110
HSK DIN69893	63		44	65	
	80	169		80	110
	100		46	80	110
CAPTO ISO28623	C5			65	
	C6	164	39		
	C8			80	110
KM	63			65	
	80	160		80	110
	100			80	110
DIN2080	-	130	13	65	-
	40			80	110
	-	133	16	80	110
ANSIB5.18 NMTB	40	130	13	65	-
	50	133	16	80	110

\* Option: Dual Contact



# TA13.PL



caratteristiche/features



peso/weight

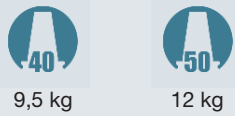

rotazione/rotation



prestazioni/performance

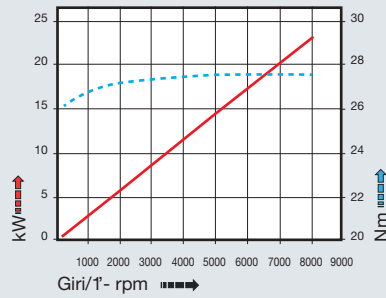

CONO SHANK	size	A	B	H	
				standard	optional
* DING9871 *	-	260	35	65	-
	40			80	110
	45			80	110
* ANSIB5.50 *	40	268	45	65	-
	50			80	110
* BT	40	268	45	65	-
	50			80	110
DING9893	63	269	44	65	-
	80		46	80	110
	100		46	80	110
ISO26623	C5	264	39	65	-
	C6			80	110
	C8			80	110
KM	63	260	13	65	-
	80			80	110
	100			80	110
DIN2080	-	230	13	65	-
	40			80	110
	-			233	16
ANSIB5.18	40	233	16	65	-
	50			80	110

tipi mandrino disponibili / available spindle types

- 1** DIN6388-ER ER25
- 2** Albero portafresa Milling shaft Ø16-Ø22
- 3** Weldon Whistle-Notch Ø16

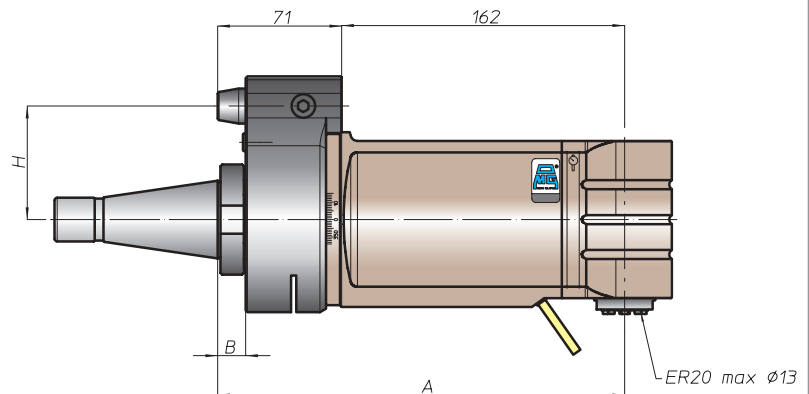
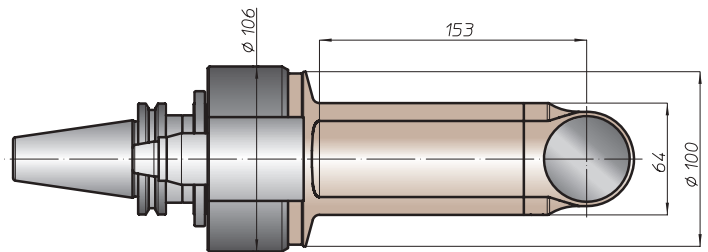
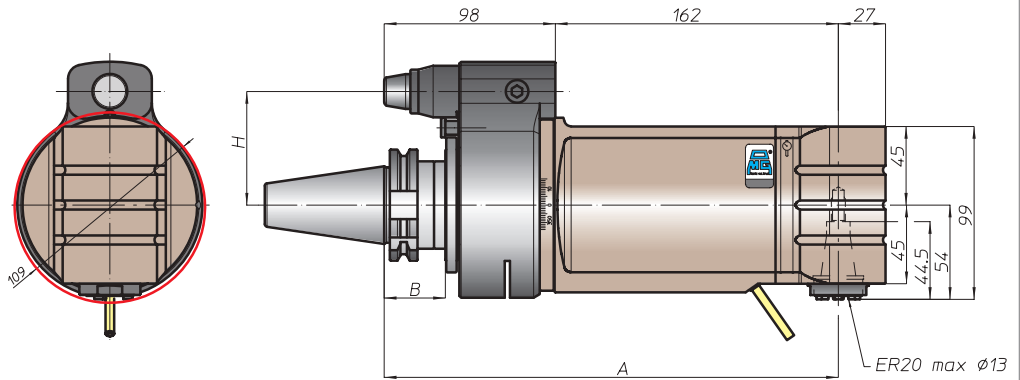

\* Option: Dual Contact



FH  
BAH  
TA.CP  
TA  
MO  
HT  
VH  
TSI/TSX  
T  
MT-TC-TC3  
Accessori Accessories  
Appendice tecnica Technical supplement

# TA16.P



caratteristiche/features

  $\phi$  16   
  M12   
  1040 N  
 1-1   
  5000

peso/weight

 40   
  50  
 7,7 kg    11,7 kg

rotazione/rotation

 IN   
  OUT

prestazioni/performance

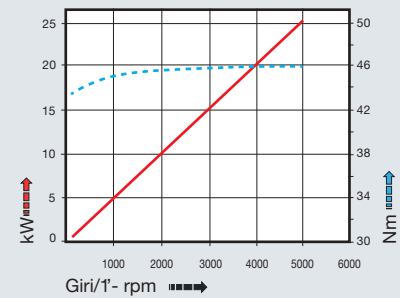

tipi mandrino disponibili / available spindle types

- 1** DIN6388-ER  
ER32
- 2** Albero portafrese  
Milling shaft  
Ø16-Ø22-Ø27-Ø32
- 3** Weldon  
Whistle-Notch  
Ø20
- 4** DIN69893-HSK  
HSK32
- 5** COROMANT  
CAPTO®  
C3
- 6** ABS  
Licenza KOMET®  
ABS32

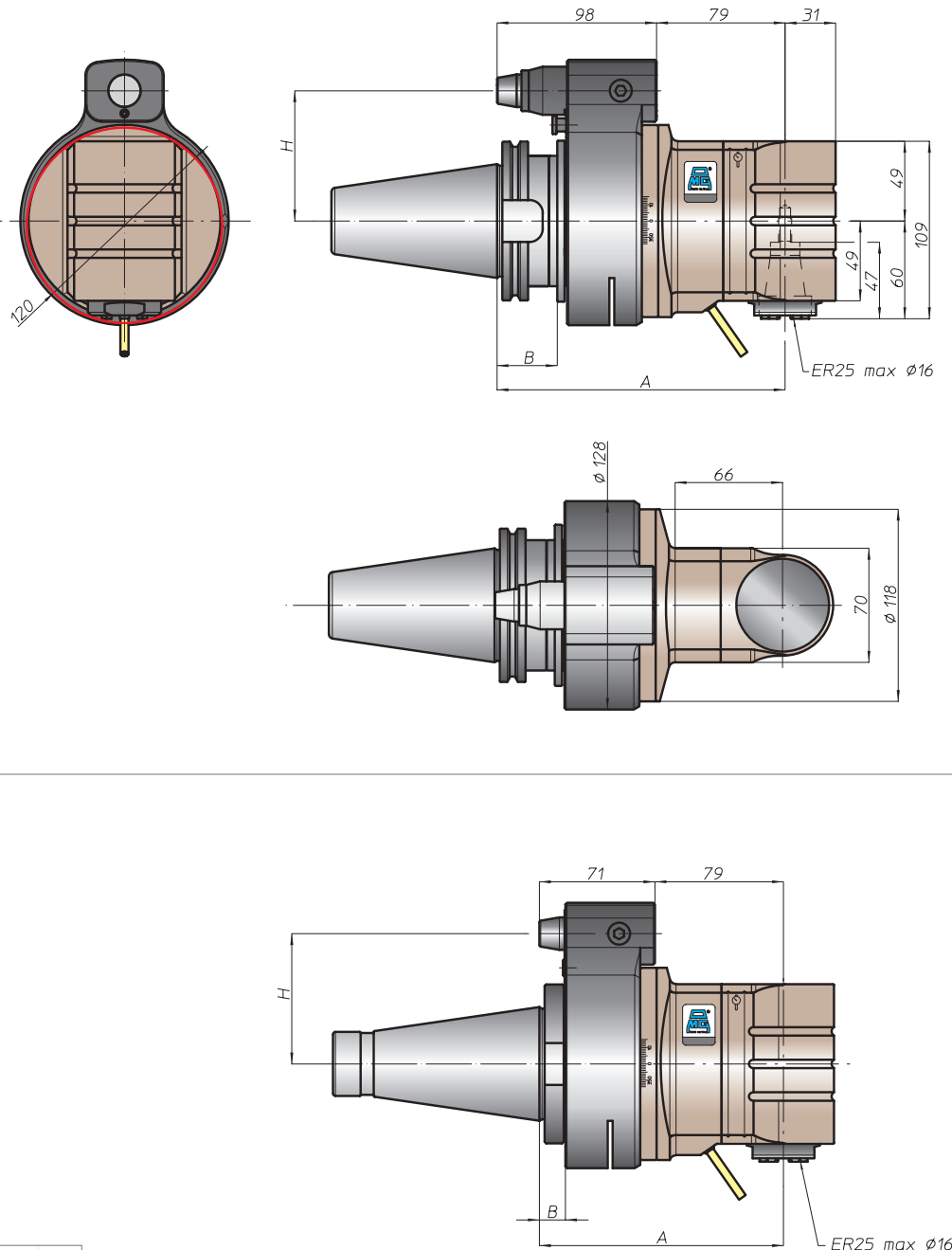

CONO SHANK	size	H			
		A	B	standard	optional
* DIN69871	-	172		65	-
	40			80	110
	45	177	35		
* ANSIB5.60 CAT	40	172		65	-
	50	177		80	110
* BT	40	172		65	
	50	185	45	80	110
HSK DIN69893	63	181	44	65	
	80			80	110
	100	186	46		
CAPTO ISO26623	C5	176		65	
	C6		39		
	C8	181		80	110
KM	63	172		65	
	80			80	110
	100	177			
DIN2080	-	147	13	65	-
	40			80	110
	50	150	16		
ANSIB5.18 NMTB	40	142	13	65	-
	50	150	16	80	110

\* Option: Dual Contact



# TA16.PL

caratteristiche/features



peso/weight



15,5 kg

rotazione/rotation



input



output

prestazioni/performance

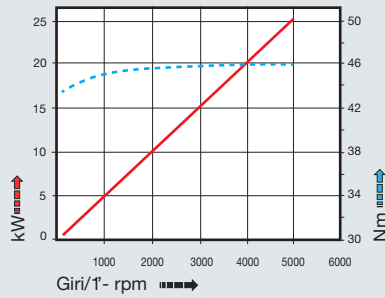

CONO SHANK	size	A	B	H	
				standard	optional
DIN69871 *	-	-	-	-	-
ANSIB5.50 *	45	277	35	80	110
	50			80	110
ANSIB5.50 CAT	-	-	-	-	-
	50	277	-	80	110
* BT	-	-	-	-	-
	50	285	45	80	110
HSK	-	-	-	-	-
	DIN69893	80	286	46	80
	100	110			
CAPTO	-	-	-	-	-
	ISO26623	C6	281	39	80
	C8	110			
KM	-	-	-	-	-
		80	277	-	80
	100	110			
DIN2080	-	-	-	-	-
		-	250	16	80
	50	110			
NMTB	-	-	-	-	-
	ANSIB5.18	50	250	16	80
				110	

tipi mandrino disponibili / available spindle types

- 1 DIN6388-ER  
**ER32**
- 2 Albero portafresa  
Milling shaft  
**Ø16-Ø22-Ø27-Ø32**
- 3 Weldon  
Whistle-Notch  
**Ø20**
- 4 DIN69893-HSK  
**HSK32**
- 5 COROMANT  
CAPTO®  
**C3**
- 6 ABS  
Licenza KOMET®  
**ABS32**

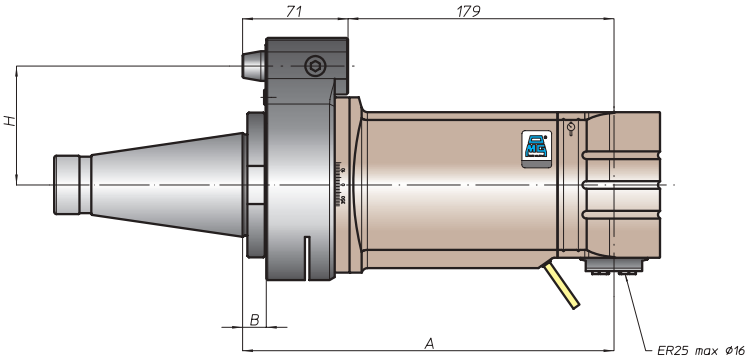
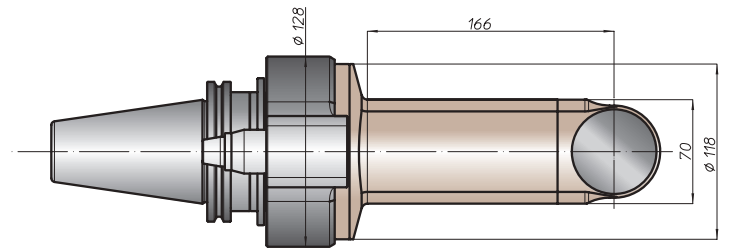
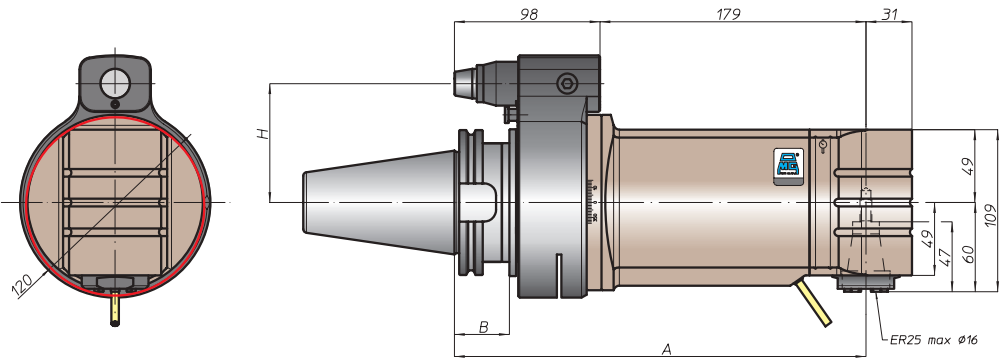

\* Option: Dual Contact



FH  
 BAH  
 TA.CP  
 TA  
 MO  
 HT  
 VH  
 TSI/TSX  
 T  
 MT-TC-TC3  
 Accessori  
 Accessories  
 Appendice tecnica  
 Technical supplement

testa ad angolo - angle head

# TA20.P



caratteristiche/features

  $\phi 20$ 
 M14
  1460 N

 1-1
  3500

peso/weight



14,5 kg

rotazione/rotation



input



output

prestazioni/performance

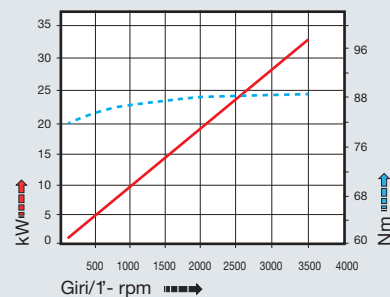

tipi mandrino disponibili / available spindle types

- 1** DIN6388-ER  
ER40
- 2** Albero portafrese  
Milling shaft  
Ø22-Ø27-Ø32
- 3** Weldon  
Whistle-Notch  
Ø20-Ø25-Ø32
- 4** DIN69893-HSK  
HSK40
- 5** COROMANT  
CAPTO®  
C4
- 6** ABS  
Licenza KOMET®  
ABS40

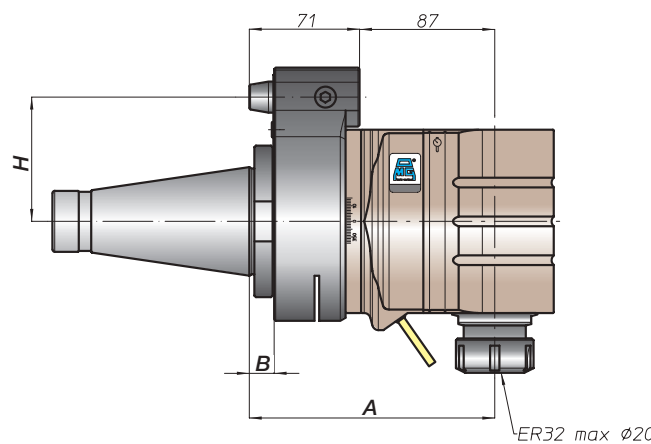
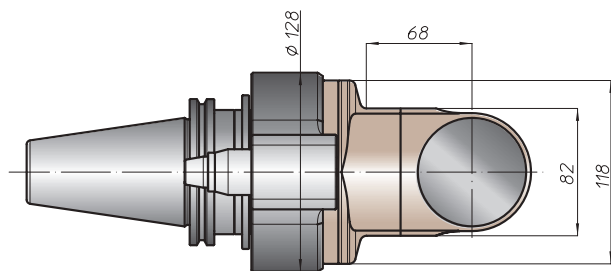
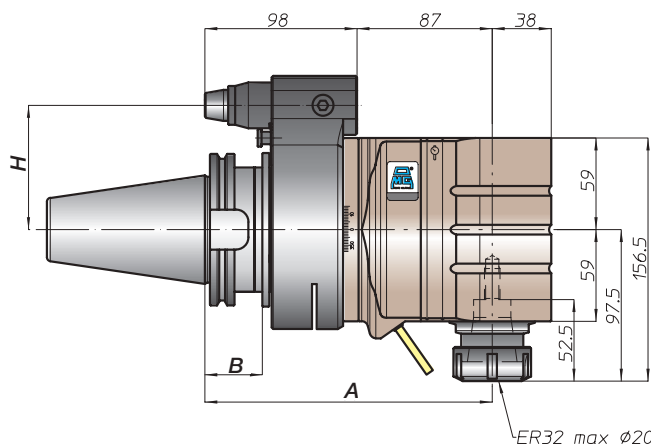
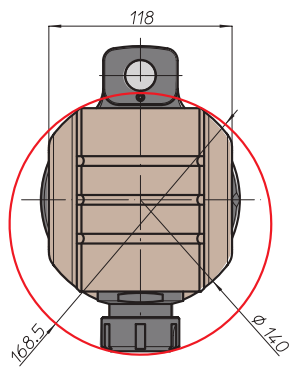

CONO SHANK	size	H			
		A	B	standard	optional
DIN69871 *	-	-	-	-	-
DIN69871 *	45	-	-	80	110
	50	185	35	80	110
ANSIB5.50 *	CAT	-	-	-	-
	50	-	-	80	110
BT *	-	-	-	-	-
	50	193	45	80	110
HSK	-	-	-	-	-
	DIN69893	80	194	46	80
CAPTO	-	-	-	-	-
	ISO28623	-	189	80	110
KM	-	-	-	-	-
	80	185	-	80	110
DIN2080	-	-	-	-	-
	50	158	16	80	110
NMTB	-	-	-	-	-
	ANSIB5.18	50	158	16	80

\* Option: Dual Contact





# TA20.PL



caratteristiche/features



peso/weight









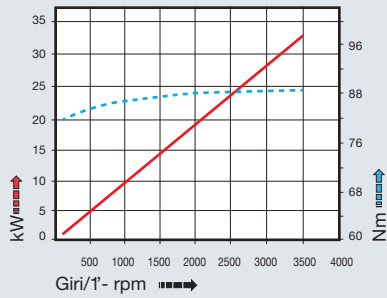

19 kg

rotazione/rotation



prestazioni/performance



CONO SHANK	size	A	B	H	
				standard	optional
DIN69871 *	-	-	-	-	-
	45	260	35	80	110
	50			80	110
ANSIB5.50 *	-	-	-	-	-
	50	-	-	80	110
	-	-	-	-	-
BT *	-	-	-	-	-
	50	268	45	80	110
	-	-	-	-	-
HSK	-	-	-	-	-
	80	269	46	80	110
	100			80	110
CAPTO	-	-	-	-	-
	-	264	-	80	110
	C8			80	110
KM	-	-	-	-	-
	80	260	-	80	110
	100			80	110
DIN2080	-	-	-	-	-
	-	233	16	80	110
	50			80	110
NMTB	-	-	-	-	-
	-	233	16	80	110
	50			80	110

tipi mandrino disponibili / available spindle types

- 1** DIN6388-ER  
ER40
- 2** Albero portafresa  
Milling shaft  
Ø22-Ø27-Ø32
- 3** Weldon  
Whistle-Notch  
Ø20-Ø25-Ø32
- 4** DIN69893-HSK  
HSK40
- 5** COROMANT  
CAPTO®  
C4
- 6** ABS  
Licenza KOMET®  
ABS40

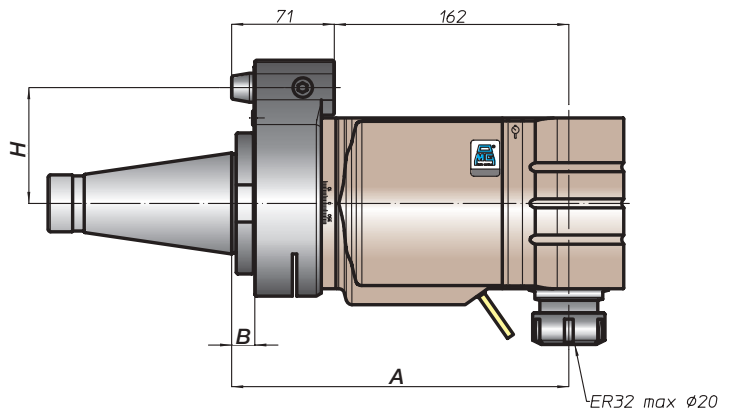
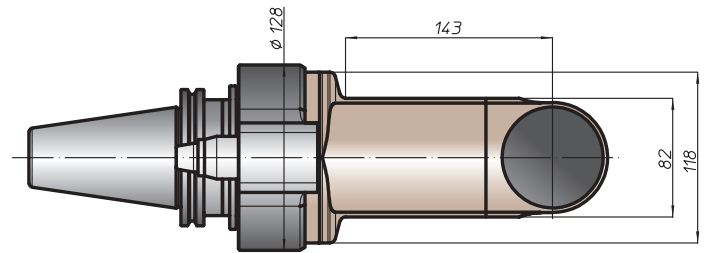
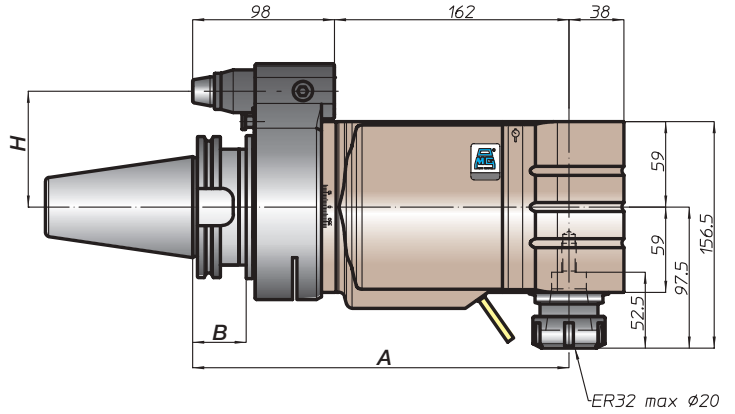
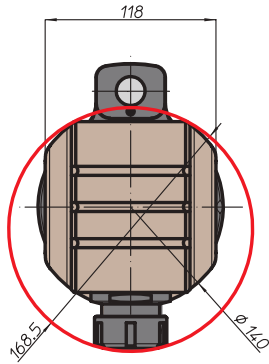

\* Option: Dual Contact



FH  
BAH  
TA.CP  
TA  
MO  
HT  
VH  
TSI/TSX  
T  
MT-TC-TC3  
Accessori  
Accessories  
Appendice tecnica  
Technical supplement

# TA Extended Gallery



# TA20.30



caratteristiche/features

$\varnothing$  20    M14    1460 N  
 1-1    3500

peso/weight



14,7 kg

rotazione/rotation

input    output

prestazioni/performance

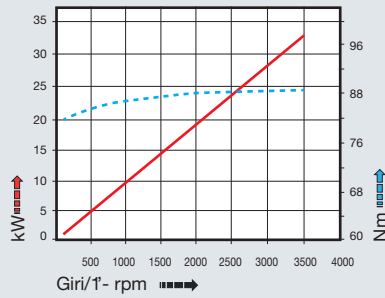

CONO SHANK	size	A	B	H	
				standard	optional
DING9871 *	-	185	35	-	-
	45			80	110
	50			80	110
ANSIB5.50 *	-	185	35	65	-
	50			80	110
BT *	-	193	45	-	-
	50			80	110
HSK	-	194	46	-	-
	80			80	110
	100			80	110
CAPTO	-	189	-	-	-
	-			80	110
	C8			80	110
KM	-	185	-	-	-
	80			80	110
	100			80	110
DIN2080	-	158	16	-	-
	-			80	110
	50			80	110
NMTB	-	158	16	-	-
	50			80	110

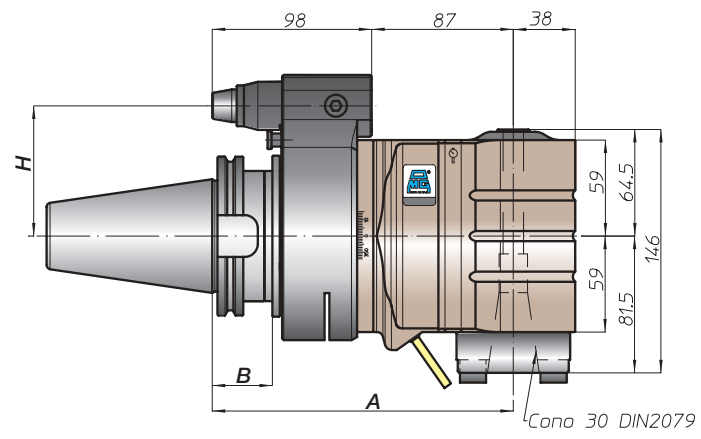
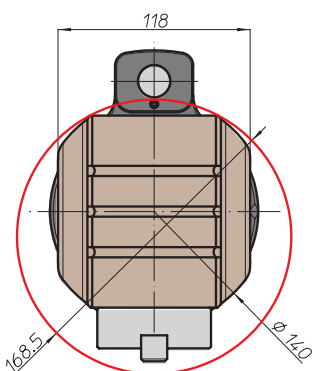

**Nota:**

- nel mandrino DIN2079 si possono utilizzare coni DIN2080-30, DIN69871-A30, MAS403-BT30

**Note:**

- on the spindle DIN2079 you can use shank DIN2080-30, DIN69871-A30, MAS403-BT30

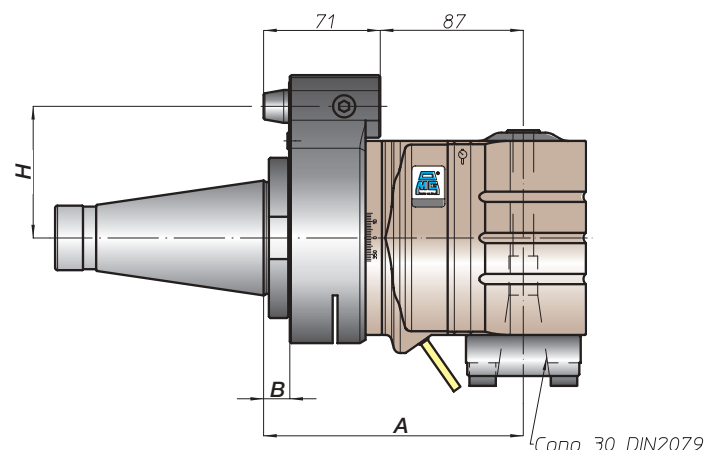
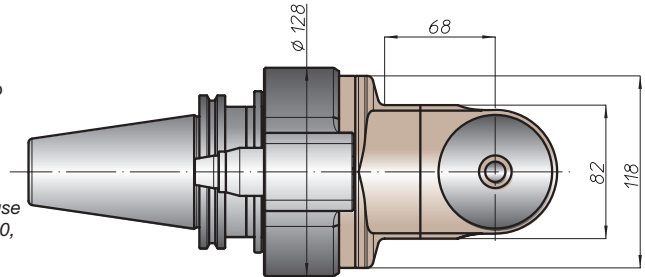

\* Option: Dual Contact



FH  
 BAH  
 TA.CP  
 TA  
 MO  
 HT  
 VH  
 TSI/TSX  
 T  
 MT-TC-TC3  
 Accessori  
 Accessories  
 Appendice tecnica  
 Technical supplement

# TA26.P



caratteristiche/features

ø 26    M20    3020 N

1-1    2500

peso/weight

22 kg

rotazione/rotation

→   
 input                      output

prestazioni/performance

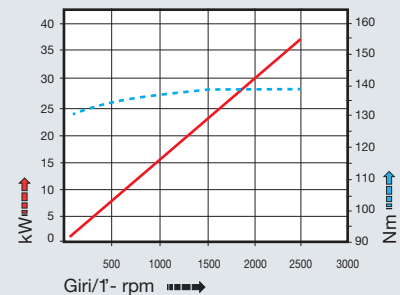

tipi mandrino disponibili / available spindle types

- 2** Albero portafresa  
Milling shaft  
Ø16-Ø27-Ø32
- 3** Weldon  
Whistle-Notch  
Ø32
- 4** DIN69893-HSK  
HSK63
- 5** COROMANT  
CAPTO®  
C4
- 6** ABS  
Licenza KOMET®  
ABS50

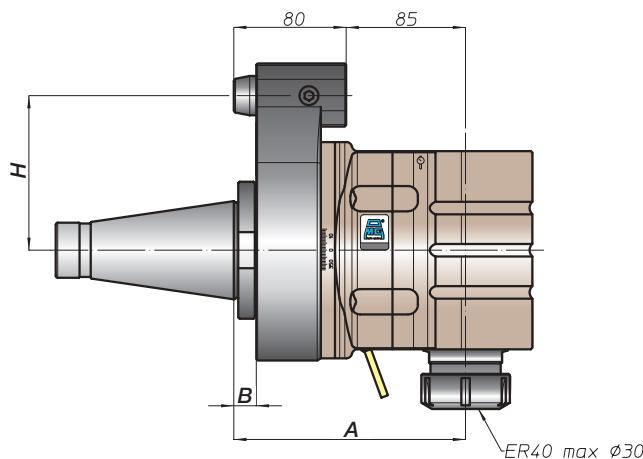
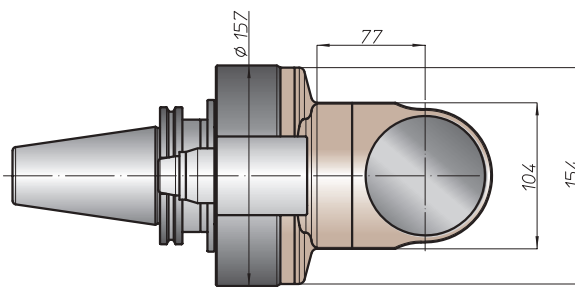
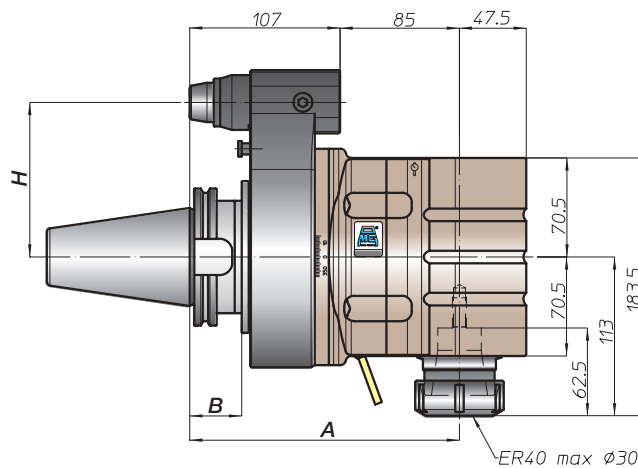
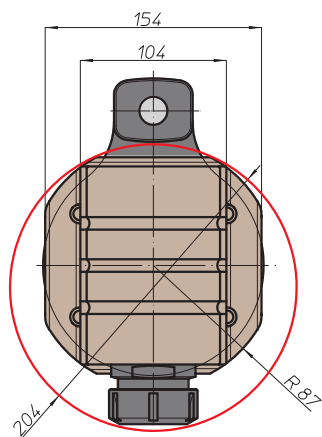

CONO SHANK	size	H			
		A	B	standard	optional
DIN69871 *	-	-	-	-	-
	45	-	-	110	-
	50	192	35	-	-
ANSIB5.50 *	CAT	-	-	-	-
	50	-	-	110	-
BT *	-	-	-	-	-
	50	200	45	110	-
HSK	-	-	-	-	-
DIN69893	80	201	46	110	-
	100	-	-	-	-
CAPTO	-	-	-	-	-
ISO28623	-	196	-	110	-
	C8	-	-	-	-
KM	-	-	-	-	-
	100	192	-	110	-
DIN2080	-	-	-	-	-
	50	165	16	110	-
NMTB	-	-	-	-	-
ANSIB5.18	50	165	16	110	-

\* Option: Dual Contact



# TA26.40

caratteristiche/features



peso/weight



rotazione/rotation



prestazioni/performance

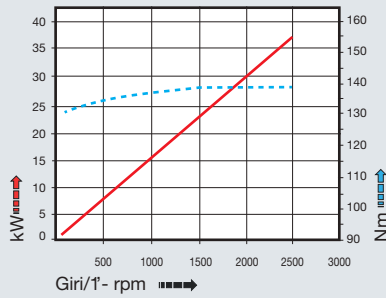

CONO SHANK	size	A	B	H	
				standard	optional
* DING9871 *	-	192	35	-	-
	45			110	-
ANSIB5.50 *	CAT	192	35	-	-
	50			110	-
* BT	-	200	45	110	-
	50			110	-
HSK	-	201	46	110	-
	80			110	-
DING9893	-	196	46	110	-
	100			110	-
CAPTO	-	196	46	110	-
	C8			110	-
KM	-	192	35	110	-
	100			110	-
DIN2080	-	165	16	110	-
	50			110	-
NMTB	-	165	16	110	-
	50			110	-

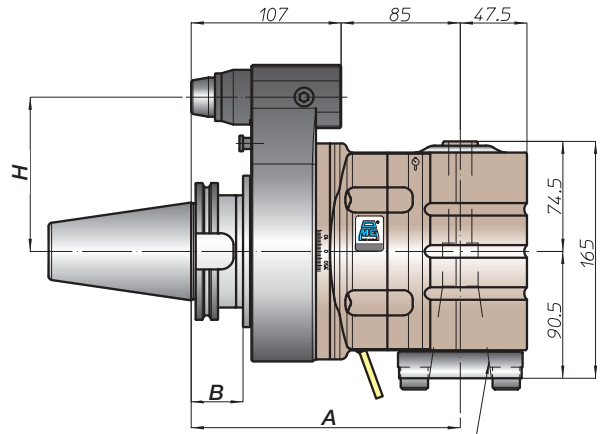
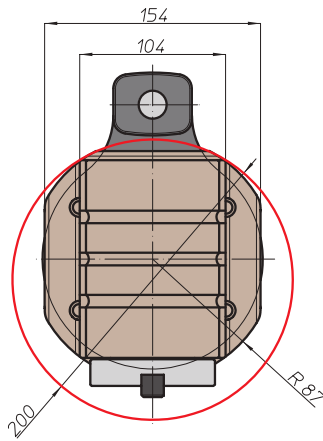

Cono 40 DIN2079

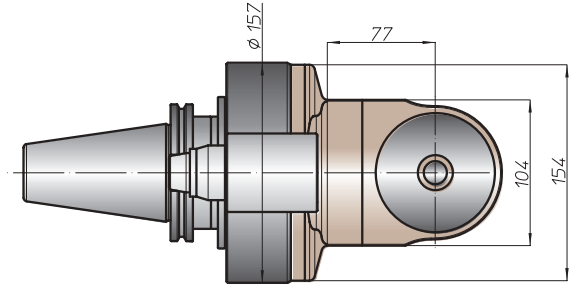

Nota:

- nel mandrino DIN2079 si possono utilizzare coni DIN2080-40, DIN69871-A40, MAS403-BT40

Note:

- on the spindle DIN2079 you can use shank DIN2080-40, DIN69871-A40, MAS403-BT40

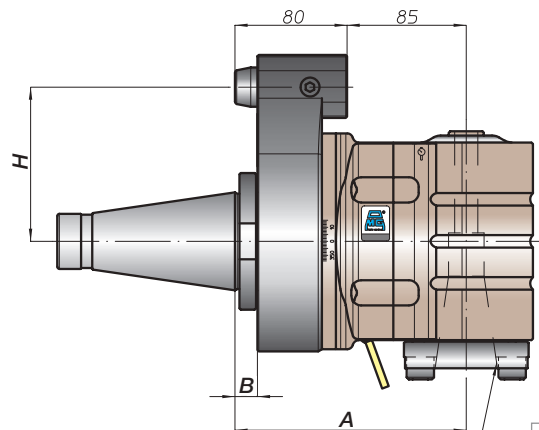

Cono 40 DIN2079

\* Option: Dual Contact



testa ad angolo - angle head

# TA07.2P



caratteristiche/features



  
 ø 7    M6    180 N  

  
 1-1    10000

peso/weight

  
 5 kg    7 kg

rotazione/rotation

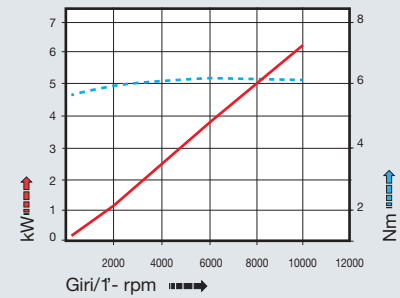

  
 input    output

prestazioni/performance

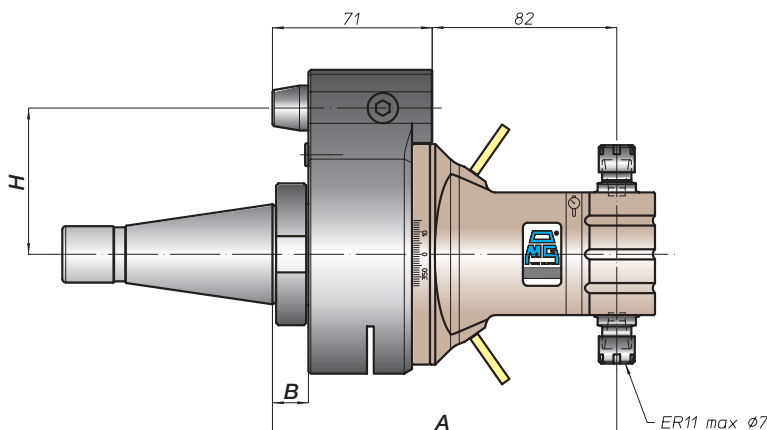
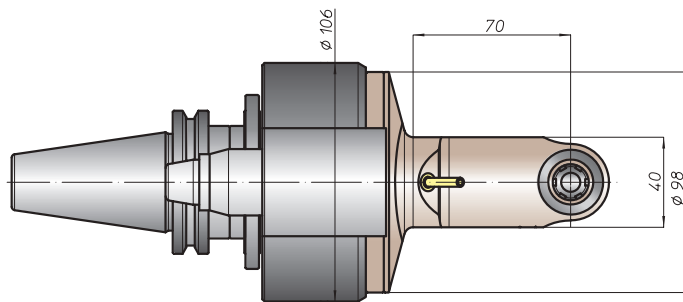
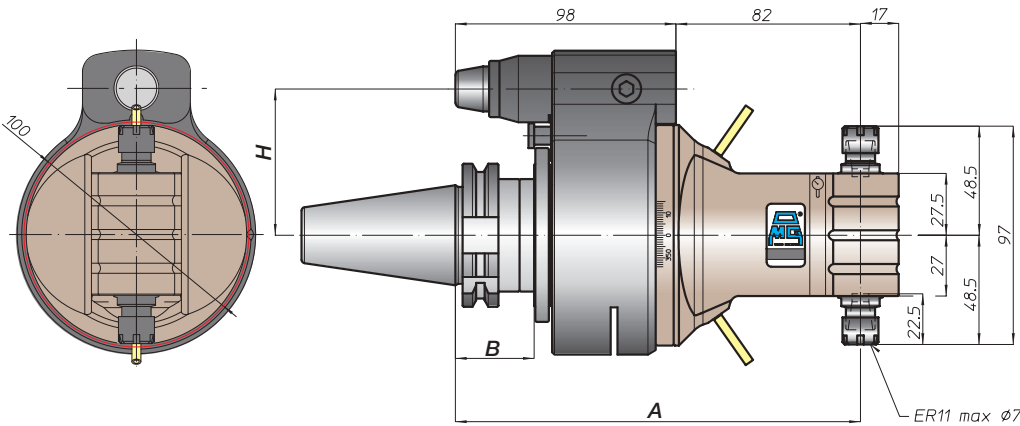

tipi mandrino disponibili / available spindle types

3 Weldon Whistle-Notch  
Ø10



CONO SHANK	size	H			
		A	B	standard	optional
* DING9871	30			65	-
	40			80	110
	45			80	110
	50	180	35	80	110
* ANSIB5.50 CAT	40			65	-
	50			80	110
* BT	40			65	
	50	188	45	80	110
DING9893 HSK	63		44	65	
	80	189		80	110
	100		46	80	110
ISO28623 CAPTO	C5			65	
	C6	184	39		
	C8			80	110
KM	63			65	
	80	180		80	110
	100			80	110
DIN2080	40	150	13	65	-
	50	153	16	80	110
ANSIB5.18 NMTB	40	150	13	65	-
	50	153	16	80	110

\* Option: Dual Contact



# TA10.2P



caratteristiche/features



peso/weight



rotazione/rotation



prestazioni/performance

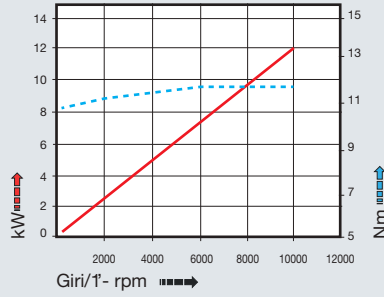

CONO SHANK	size	A	B	H	
				standard	optional
DING9871 *	30	180	35	65	-
	40			80	110
	45			80	110
	50			80	110
ANSIB5.50 *	CAT			65	-
				80	110
* BT	40			65	
	50	188	45	80	110
HSK	63	189	44	65	
	80		46	80	110
	100				
CAPTO	C5	184	39	65	
	C6			80	110
	C8				
KM	63	180		65	
	80			80	110
	100				
DIN2080	-	150	13	65	-
	40	153	16	80	110
	50				
ANSIB5.18 NMTB	40	150	13	65	-
	50	153	16	80	110

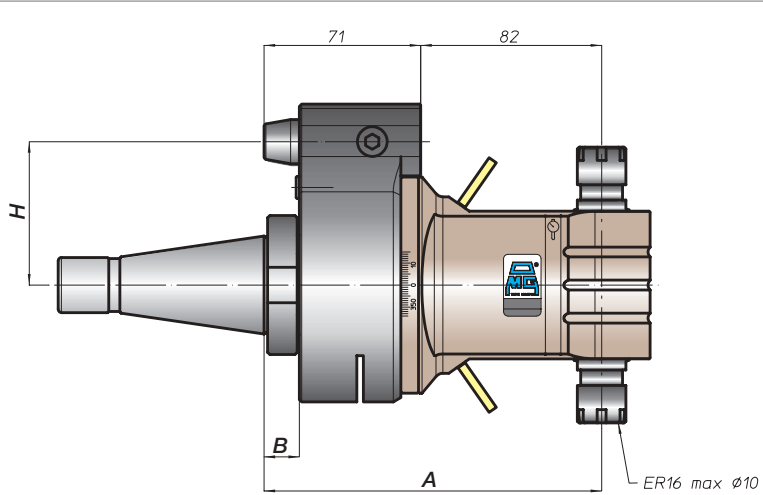
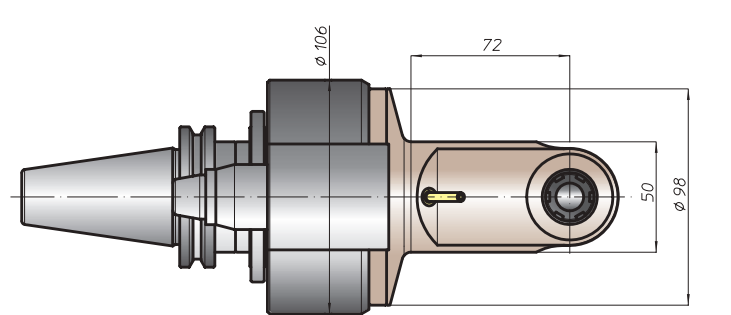
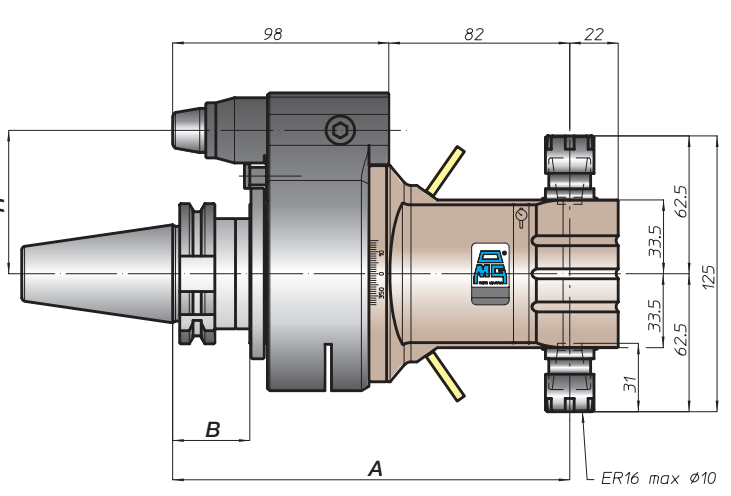
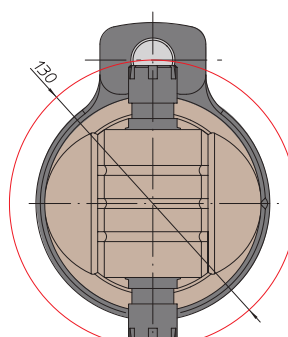

\* Option: Dual Contact



FH  
BAH  
TA.CP  
TA  
MO  
HT  
VH  
TSI/TSX  
T  
MT-TC-TC3  
Accessori  
Accessories  
Appendice tecnica  
Technical supplement

# TA13.2P



caratteristiche/features

$\phi$  13   
 M10   
 810 N  
 1-1   
 8000

peso/weight

40   
 50  
 6,5 kg    9 kg

rotazione/rotation

IN   
 OUT

prestazioni/performance

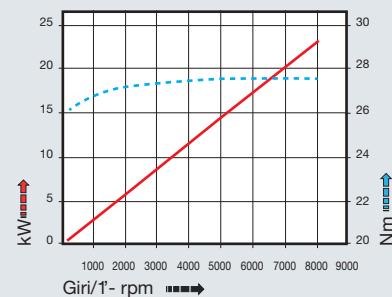

tipi mandrino disponibili / available spindle types

**1** DIN6388-ER  
ER25

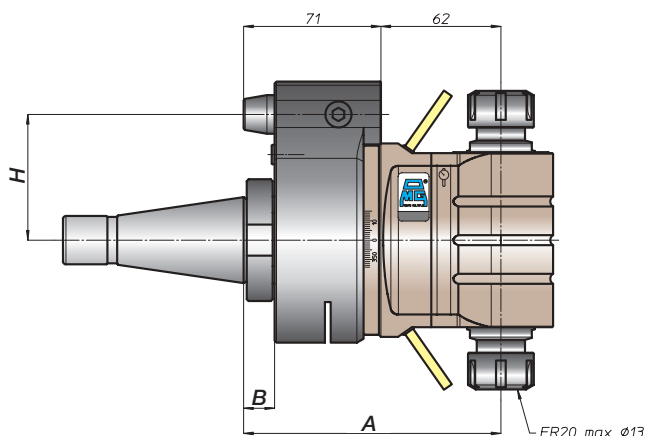
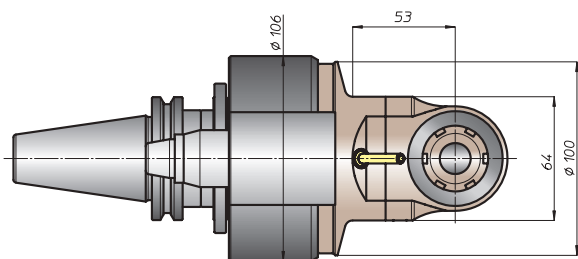
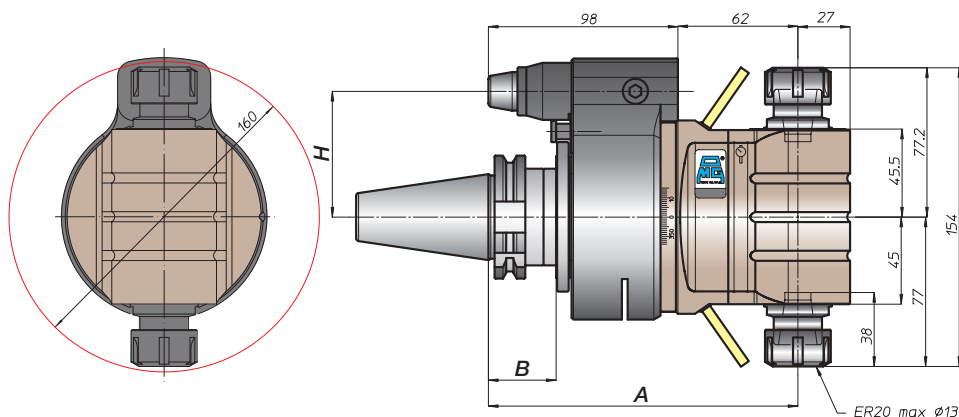

CONO SHANK	size	H			
		A	B	standard	optional
* DIN69871	-			65	-
	40	160	35	80	110
	45				
50					
* CAT	40			65	-
	50			80	110
* BT	40			65	
	50	168	45	80	110
HSK	63		44	65	
	80	169		80	110
	100		46	80	110
CAPTO	C5			65	
	C6	164	39		
	C8			80	110
KM	63			65	
	80	160		80	110
	100				
DIN2080	-	130	13	65	-
	40				
	-	133	16	80	110
ANSI B5.18	40	130	13	65	-
	50	133	16	80	110

\* Option: Dual Contact





# TA16.2P



caratteristiche/features



peso/weight

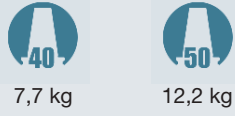

rotazione/rotation



prestazioni/performance

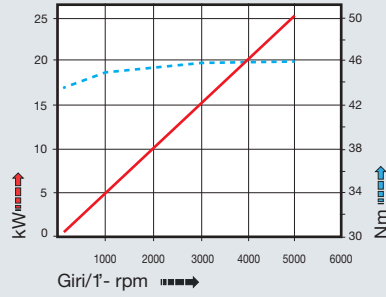

CONO SHANK	size	A	B	H	
				standard	optional
DING9871 *	-	172	35	65	-
	40	177		80	110
	45	177		80	110
ANSIB5.50 * CAT	40	172	65	-	
	50	177	80	110	
* BT	40	172	65	-	
	50	185	45	80	110
HSK DING9893	63	181	44	65	-
	80	186	46	80	110
	100	186	46	80	110
CAPTO ISO26623	C5	176	39	65	-
	C6	181		80	110
	C8	181		80	110
KM	63	172	35	65	-
	80	177		80	110
	100	177		80	110
DIN2080	-	147	13	65	-
	40	150	16	80	110
	50	150	16	80	110
ANSIB5.18 NMTB	40	142	13	65	-
	50	150	16	80	110

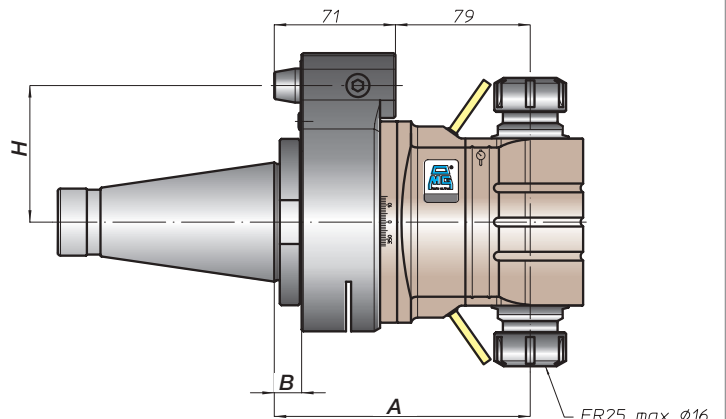
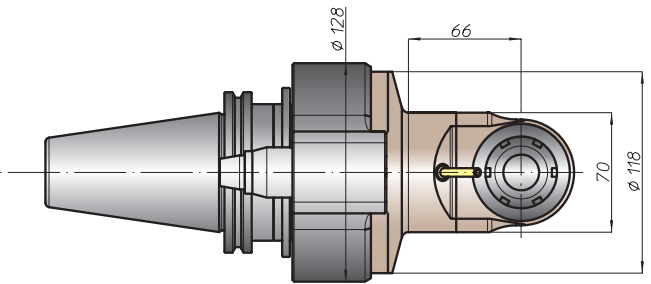
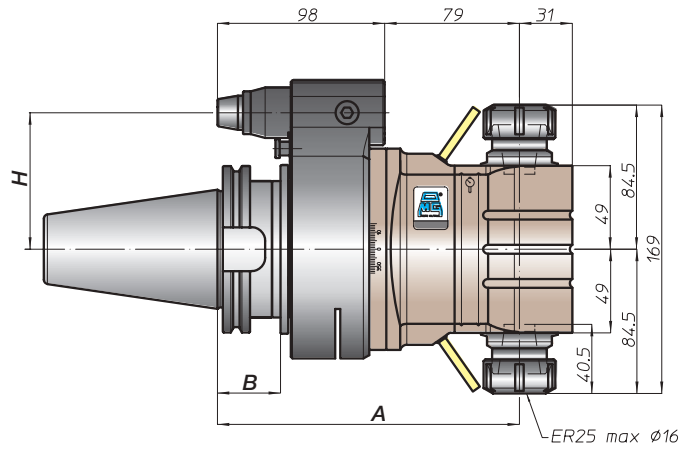
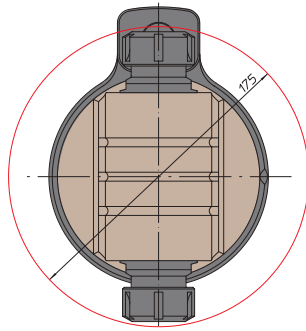

\* Option: Dual Contact



TA  
TA.CP  
BAH  
FH  
MO  
HT  
VH  
TSI/TSX  
T  
MT-TC-TC3  
Accessori  
Accessories  
Appendice tecnica  
Technical supplement

testa ad angolo - angle head

# TA20.2P



caratteristiche/features



  
 ø 20 M14 1460 N

  
 1-1 3500

peso/weight



15 kg

rotazione/rotation



input



output

prestazioni/performance

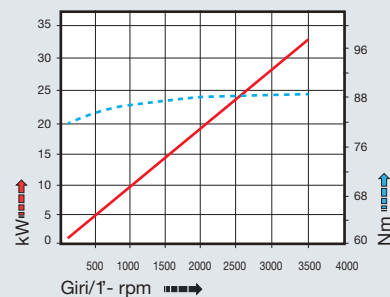

tipi mandrino disponibili / available spindle types

- 2** Albero portafresa  
Milling shaft  
Ø32
- 3** Weldon  
Whistle-Notch  
Ø20

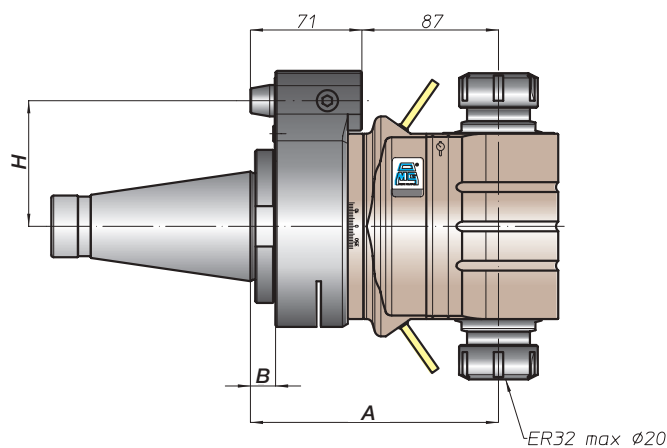
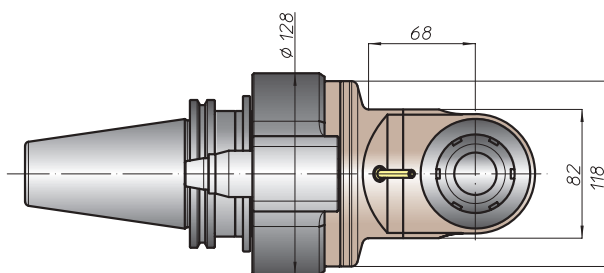
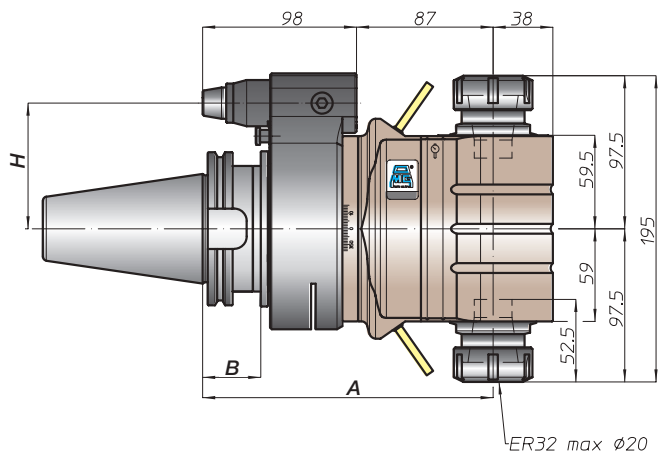
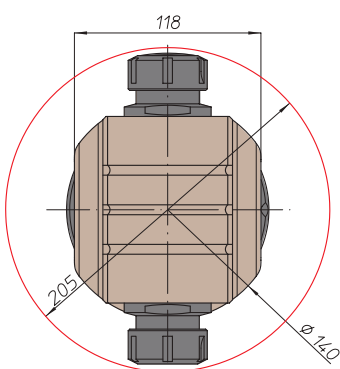

CONO SHANK	size	H			
		A	B	standard	optional
DIN69871 *	-	-	-	-	-
	45	-	-	80	110
	50	185	35	80	110
ANSI B5.50 *	CAT	-	-	-	-
	50	-	-	80	110
BT *	-	-	-	-	-
	50	193	45	80	110
HSK	-	-	-	-	-
DIN69893	80	194	-	80	110
	100	-	46	80	110
CAPTO	-	-	-	-	-
ISO28623	-	189	-	80	110
	C8	-	-	80	110
KM	-	-	-	-	-
	80	185	-	80	110
	100	-	-	80	110
DIN2080	-	-	-	-	-
	-	-	-	-	-
	50	158	16	80	110
NMTB	-	-	-	-	-
ANSI B5.18	50	158	16	80	110

\* Option: Dual Contact



# TA26.2P



caratteristiche/features



  
 ø 26    M20    3020 N  

  
 1-1    2500

peso/weight



22,5 kg

rotazione/rotation



input



output

prestazioni/performance

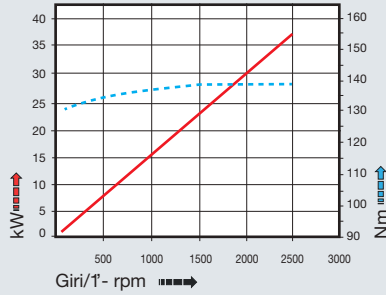

CONO SHANK	size	A	B	H	
				standard	optional
* DING9871	-	192	35	-	-
	45			110	-
* ANSIB5.50	-	192	35	-	-
	50			110	-
* BT	-	200	45	110	-
	50			110	-
HSK	-	201	46	110	-
	80			110	-
CAPTO	-	196	-	110	-
	100			110	-
KM	-	192	-	110	-
	100			110	-
DIN2080	-	165	16	110	-
	50			110	-
ANSIB5.18	-	165	16	110	-
	50			110	-

tipi mandrino disponibili / available spindle types

- 2** Albero portafresa Milling shaft
- 3** Weldon Whistle-Notch

Ø16-Ø27-Ø32    Ø32    ABS50

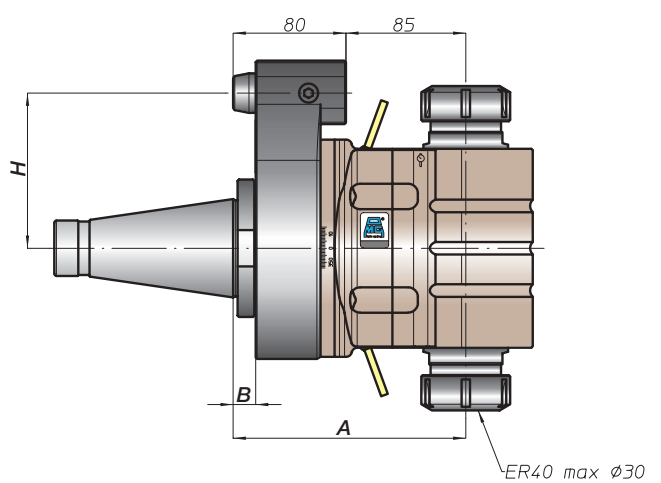
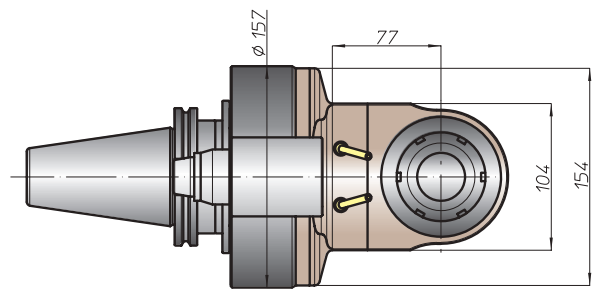
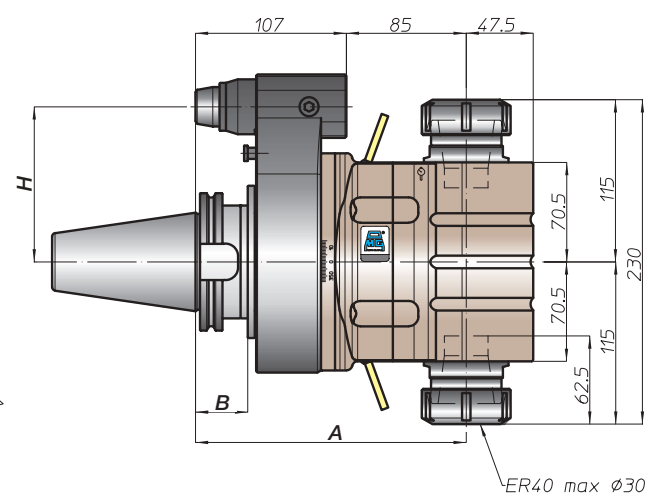
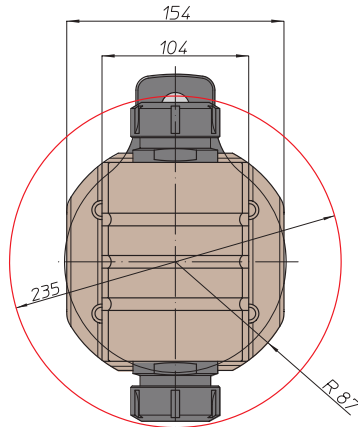

\* Option: Dual Contact



FH  
BAH  
TA.CP  
TA  
MO  
HT  
VH  
TSI/TSX  
T  
MT-TC-TC3  
Accessori  
Accessories  
Appendice tecnica  
Technical supplement

# TA07.PD



caratteristiche/features



peso/weight



rotazione/rotation



prestazioni/performance

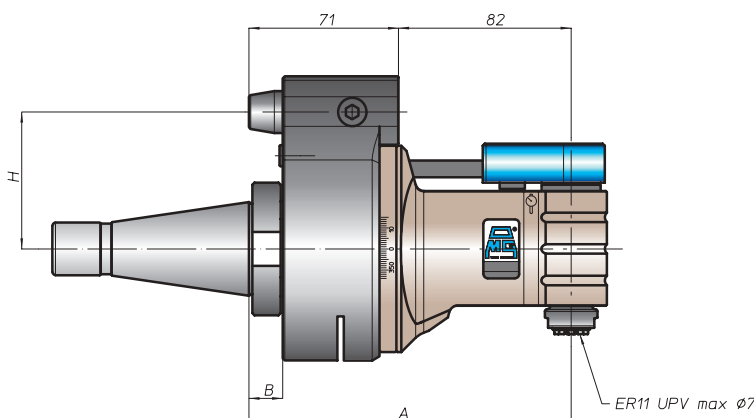
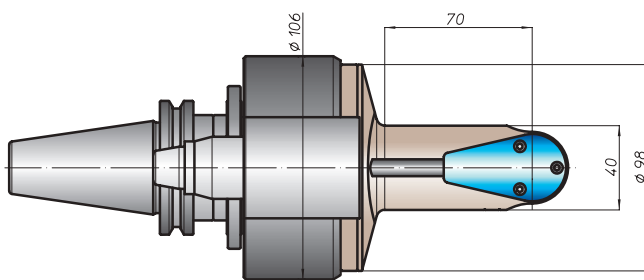
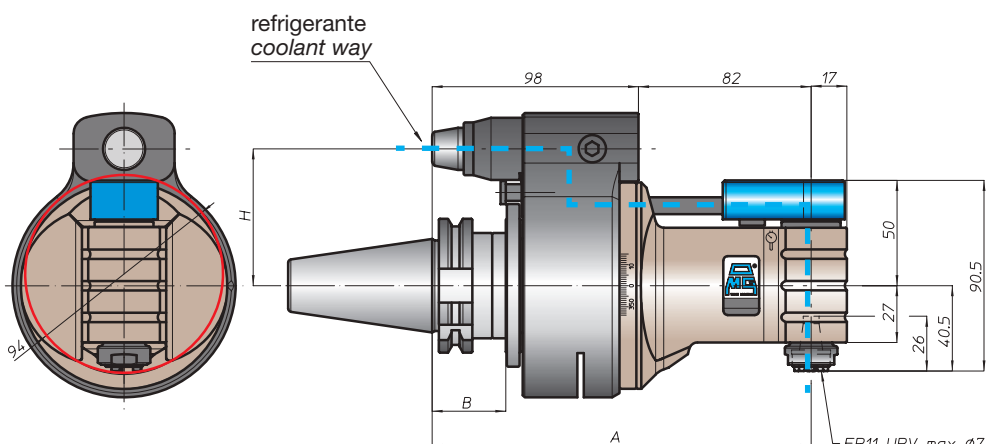
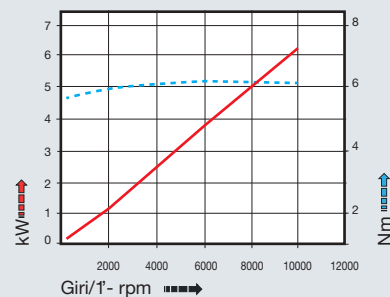

CONO SHANK	size	H			
		A	B	standard	optional
* DING9871	30			65	-
	40			80	110
	45	150	35	80	110
	50	150	35	80	110
* ANSIB5.50 CAT	40			65	-
	50			80	110
* BT	40			65	
	50	158	45	80	110
DING9893 HSK	63		44	65	
	80	159		80	110
	100		46	80	110
ISO28623 CAPTO	C5			65	
	C6	154	39		
	C8			80	110
KM	63			65	
	80	150		80	110
	100			80	110
DIN2080	40	120	13	65	-
	50	123	16	80	110
ANSIB5.18 NMTB	40	120	13	65	-
	50	123	16	80	110

\* Option: Dual Contact



# TA07.PDL



caratteristiche/features



peso/weight



rotazione/rotation



prestazioni/performance

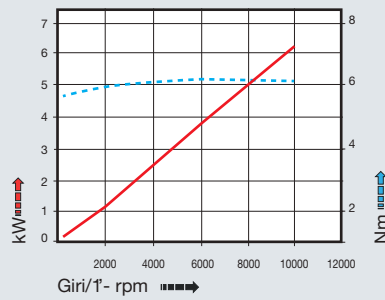

CONO SHANK	size	A	B	H	
				standard	optional
DING9871 *	-	250	35	65	-
	40			80	110
	45			80	110
ANSIB5.50 * CAT	40	254	39	65	-
	50			80	110
* BT	40	258	45	65	-
	50			80	110
DING9893 HSK	63	259	46	65	-
	80			80	110
	100			80	110
ISO26623 CAPTO	C5	254	39	65	-
	C6			80	110
	C8			80	110
KM	63	250	13	65	-
	80			80	110
	100			80	110
DIN2080	-	220	16	65	-
	40			80	110
	50			80	110
ANSIB5.18 NMTB	40	223	16	65	-
	50			80	110

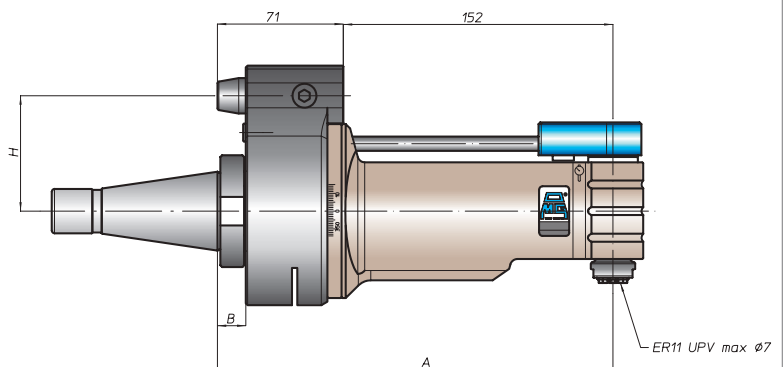
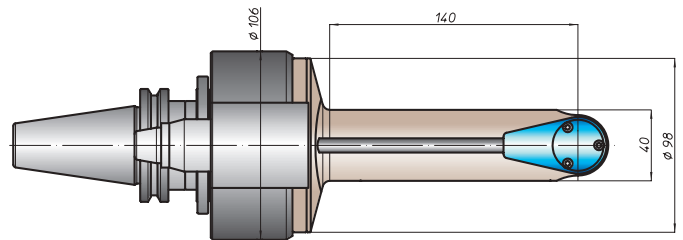
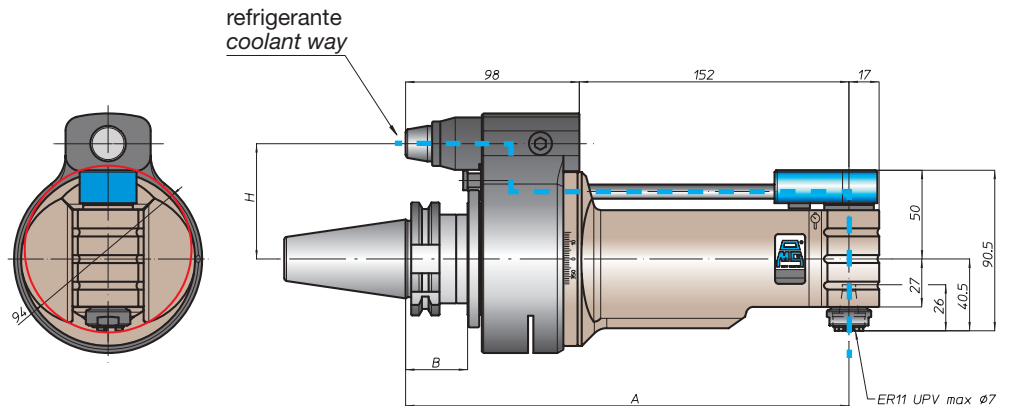

\* Option: Dual Contact



FH  
BAH  
TA.CP  
TA  
MO  
HT  
VH  
TSI/TSX  
T  
MT-TC-TC3  
Accessori  
Accessories  
Appendice tecnica  
Technical supplement

testa ad angolo - angle head

# TA10.PD



caratteristiche/features



peso/weight



rotazione/rotation



prestazioni/performance

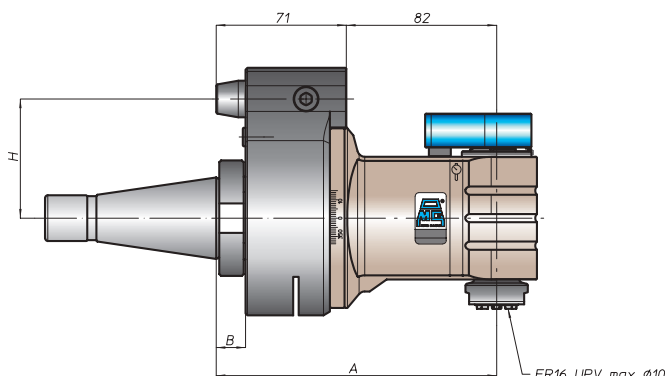
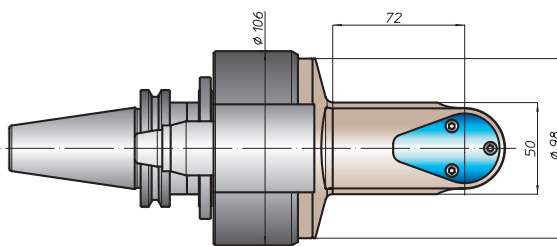
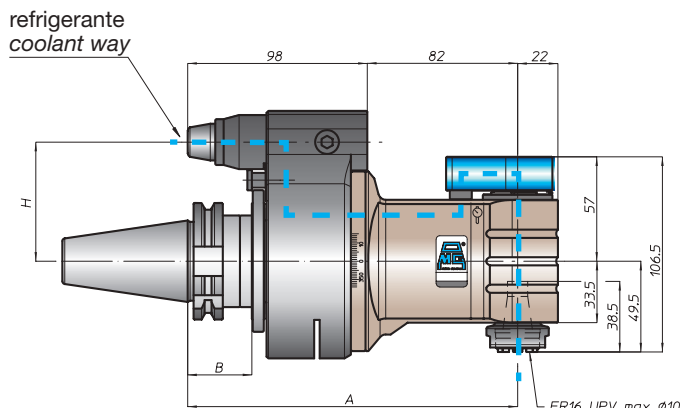
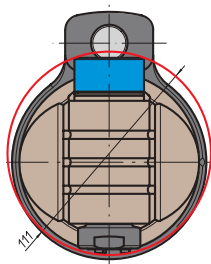
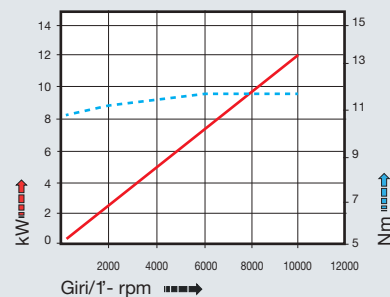

CONO SHANK	size	H			
		A	B	standard	optional
* DING9871	30	180	35	65	-
	40			80	110
	45			80	110
	50			80	110
* ANSIB5.50 CAT	40	180	35	65	-
	50			80	110
* BT	40	188	45	65	-
	50			80	110
DING9893 HSK	63	189	46	65	-
	80			80	110
	100			80	110
ISO28623 CAPTO	C5	184	39	65	-
	C6			80	110
	C8			80	110
KM	63	180	35	65	-
	80			80	110
	100			80	110
DIN2080	-	150	13	65	-
	40			80	110
	-			153	16
ANSIB5.18 NMTB	40	150	13	65	-
	50			153	16

\* Option: Dual Contact



# TA10.PDL



caratteristiche/features



peso/weight



rotazione/rotation



prestazioni/performance

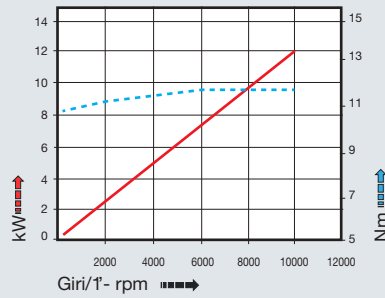

CONO SHANK	size	A	B	H	
				standard	optional
DING9871 *	40	250	35	65	-
	45			80	110
	50			80	110
ANSIB5.50 *	40	258	45	65	-
	50			80	110
BT *	40	258	45	65	-
	50			80	110
HSK DING9893	63	259	44	65	-
	80		46	80	110
	100		46	80	110
CAPTO ISO26623	C5	284	39	65	-
	C6			80	110
	C8			80	110
KM	63	250	45	65	-
	80			80	110
	100			80	110
DIN2080	40	220	13	65	-
	50			80	110
	50			223	16
ANSIB5.18 NMTB	40	220	13	65	-
	50			223	16

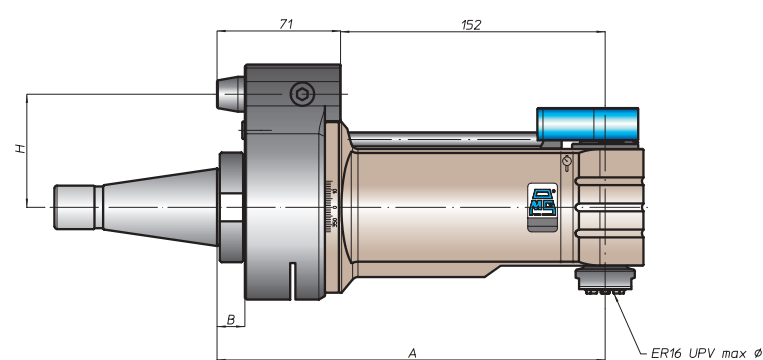
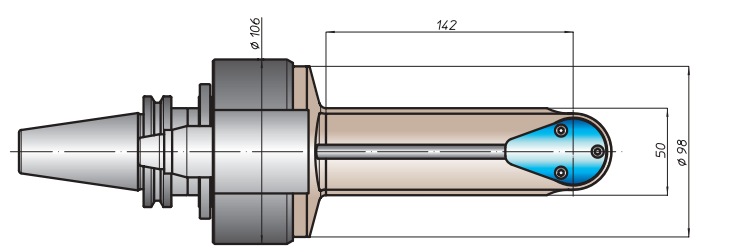
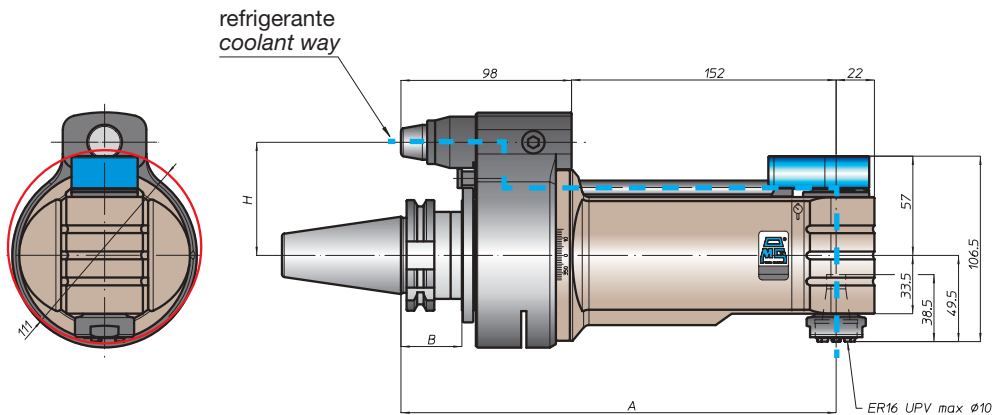

\* Option: Dual Contact



FH  
BAH  
TA.CP  
TA  
MO  
HT  
VH  
TSI/TSX  
T  
MT-TC-TC3  
Accessori  
Accessories  
Appendice tecnica  
Technical supplement

# TA13.PD



caratteristiche/features



peso/weight

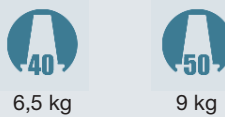

rotazione/rotation



prestazioni/performance

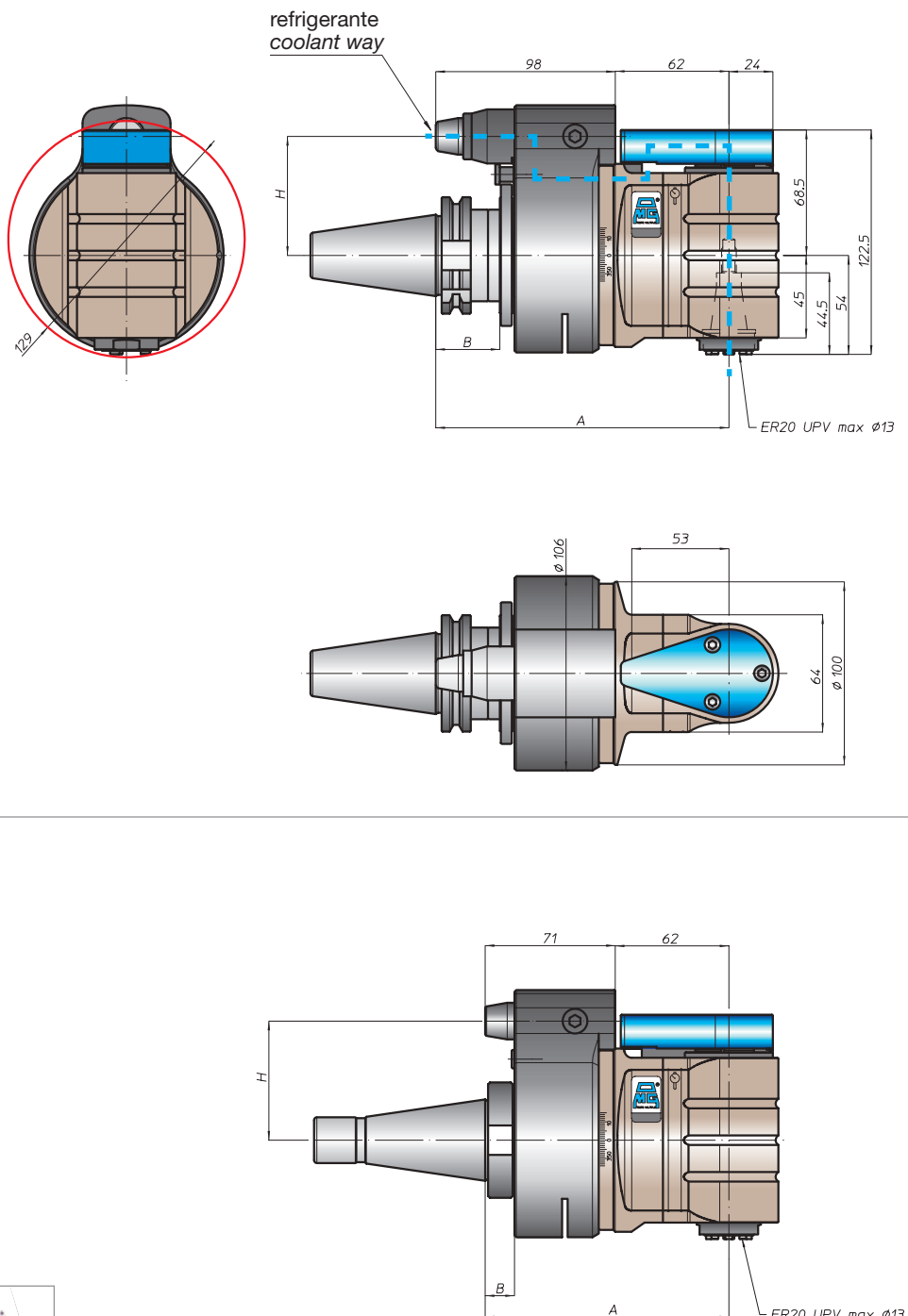
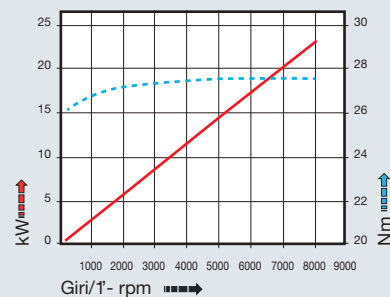

CONO SHANK	size	H			
		A	B	standard	optional
* DING9871	-			65	-
	40			65	-
	45			80	110
* CAT	40	160	35	80	110
	50			80	110
	50			80	110
* BT	40			65	
	50	168	45	80	110
HSK	63		44	65	
	80	169		80	110
	100		46	80	110
CAPTO	C5			65	
	C6	164	39		
	C8			80	110
KM	63			65	
	80	160			
	100			80	110
DIN2080	-	130	13	65	-
	40				
	50	133	16	80	110
NMTB	40	130	13	65	-
	50	133	16	80	110

\* Option: Dual Contact





# TA16.PD



caratteristiche/features

peso/weight

prestazioni/performances

$\varnothing$  16    M12    1040 N  
 1-1    5000    10 bar

7,7 kg    12 kg  
 rotazione/rotation  
 input    output

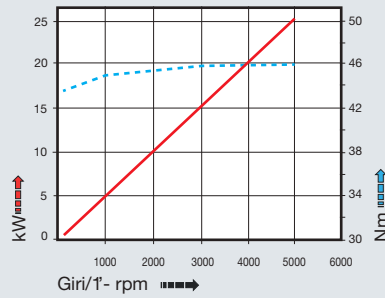

CONO SHANK	size	A	B	H	
				standard	optional
* DING9871	-	172	35	65	-
	40	172		65	-
	45	177		80	110
* ANSIB5.50 CAT	40	172	65	-	
	50	177	80	110	
* BT	40	172	65	-	
	50	185	45	80	110
DING9893 HSK	63	181	44	65	-
	80	186	46	80	110
	100	186	46	80	110
ISO26623 CAPTO	C5	176	39	65	-
	C6	181	39	80	110
	C8	181	39	80	110
KM	63	172	65	-	
	80	177	80	110	
	100	177	80	110	
DIN2080	-	147	13	65	-
	40	150	16	80	110
	50	150	16	80	110
ANSIB5.18 NMTB	40	142	13	65	-
	50	150	16	80	110

tipi mandrino disponibili / available spindle types

1 DIN6388-ER  
ER32

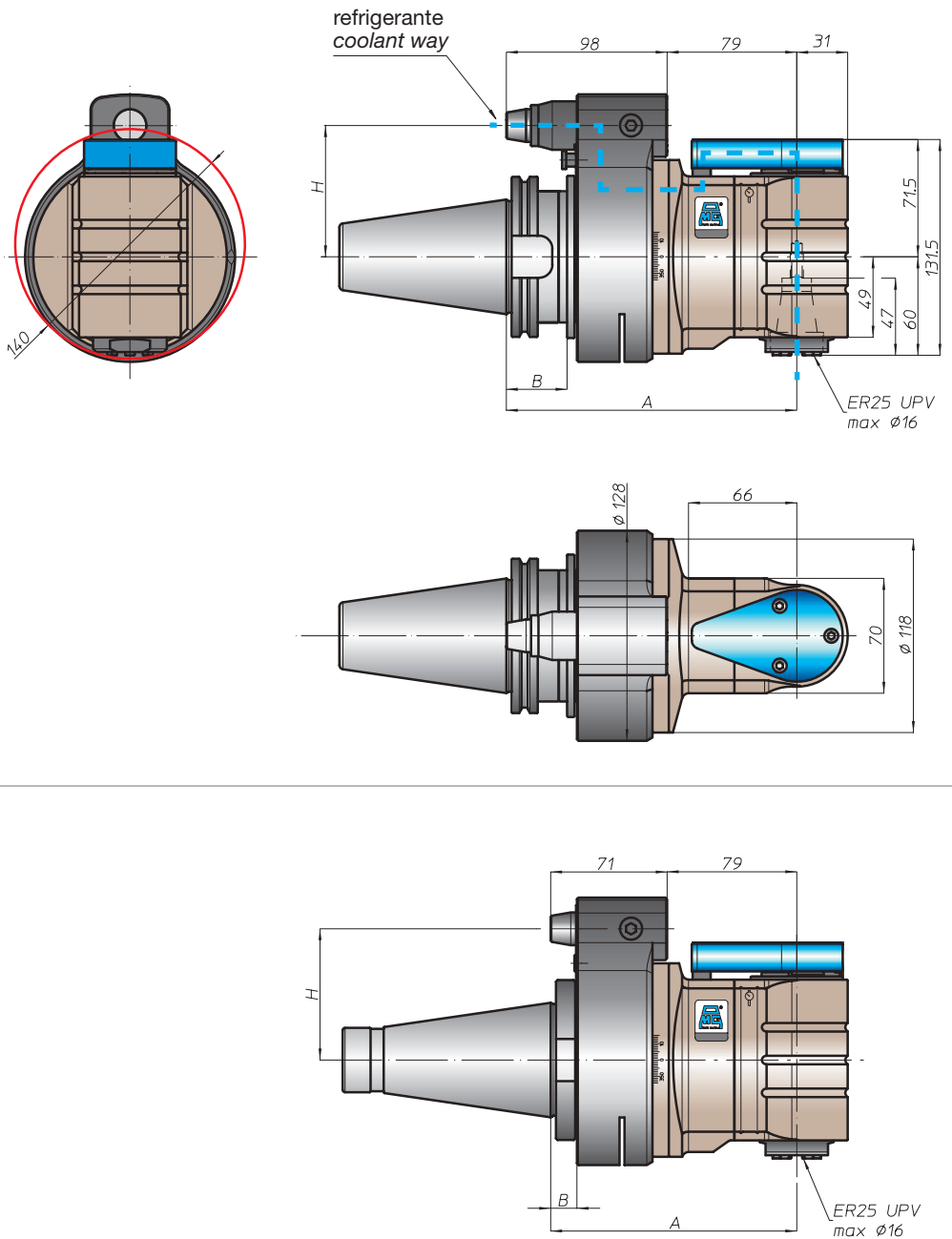

\* Option: Dual Contact



FH  
BAH  
TA.CP  
TA  
MO  
HT  
VH  
TSI/TSX  
T  
MT-TC-TC3  
Accessori  
Accessories  
Appendice tecnica  
Technical supplement

testa ad angolo - angle head

# TA20.PD



caratteristiche/features



peso/weight



14,5 kg

rotazione/rotation



input



output

prestazioni/performance

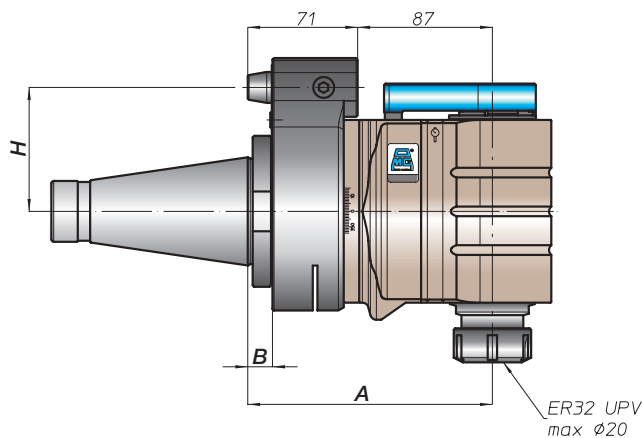
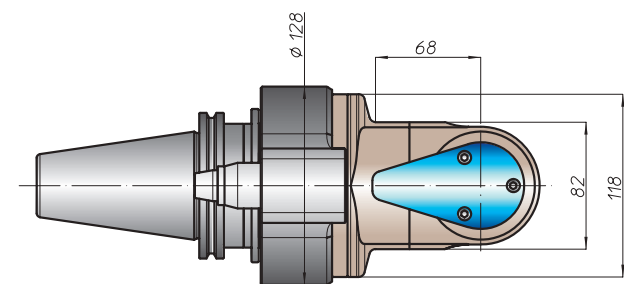
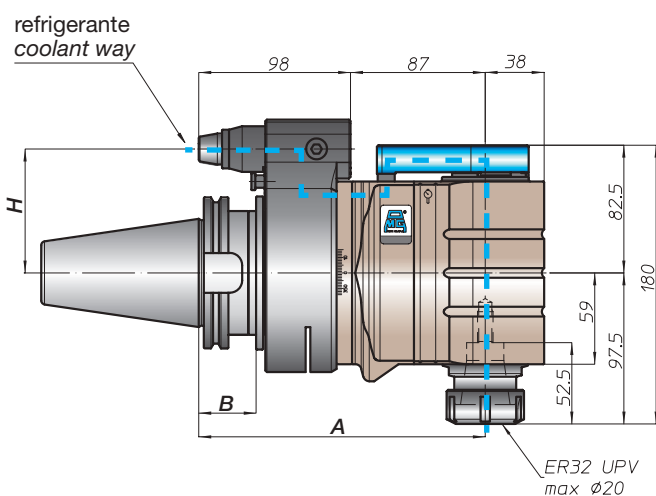
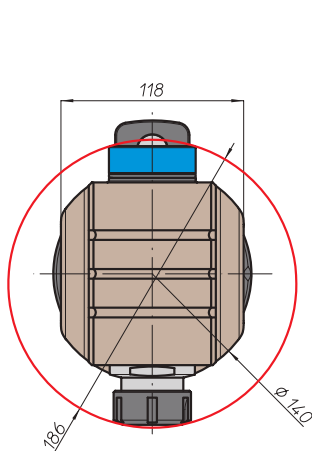
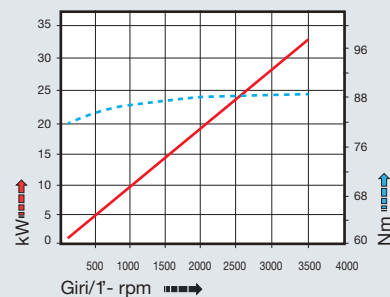

CONO SHANK	size	H			
		A	B	standard	optional
DIN69871 *	-	-	-	-	-
DIN69871 *	45	-	-	80	110
	50	185	35	80	110
ANSIB5.50 *	-	-	-	-	-
ANSIB5.50 *	50	-	-	80	110
	50	193	45	80	110
BT *	-	-	-	-	-
DIN69893	80	194	-	80	110
	100	-	46	80	110
CAPTO	-	-	-	-	-
ISO28623	-	189	-	80	110
	C8	-	-	80	110
KM	-	-	-	-	-
KM	80	185	-	80	110
	100	-	-	80	110
DIN2080	-	-	-	-	-
DIN2080	-	158	16	80	110
	50	-	-	80	110
NMTB	-	-	-	-	-
ANSIB5.18	50	158	16	80	110

\* Option: Dual Contact



# TA26.PD

caratteristiche/features

peso/weight

prestazioni/performance



22 kg

rotazione/rotation









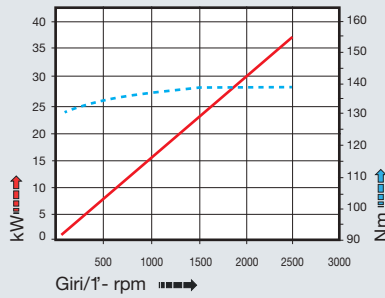

input



output



CONO SHANK	size	A	B	H	
				standard	optional
DIN9871 *	-	-	-	-	-
	45	192	37	-	-
	50			110	-
ANSIB5.50 *	-	-	-	-	-
	50	-	-	110	-
	50	-	-	110	-
BT *	-	-	-	-	-
	50	200	45	110	-
	50	200	45	110	-
HSK	-	-	-	-	-
	80	201	46	110	-
	100			110	-
CAPTO	-	-	-	-	-
	-	196	-	-	-
	C8			110	-
KM	-	-	-	-	-
	-	192	-	-	-
	100			110	-
DIN2080	-	-	-	-	-
	-	165	16	110	-
	50			110	-
NMTB	-	-	-	-	-
	-	165	16	110	-
	50			110	-

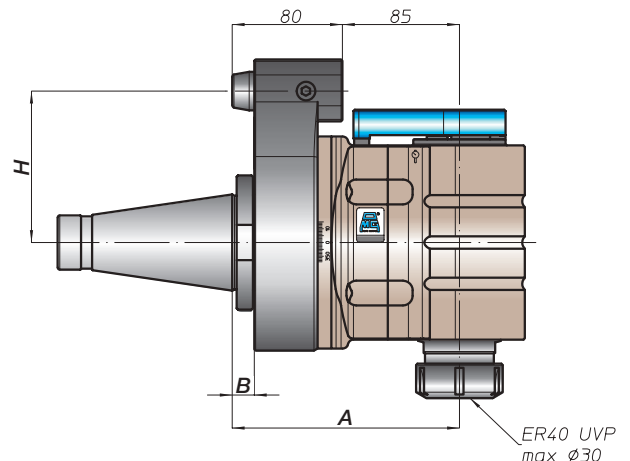
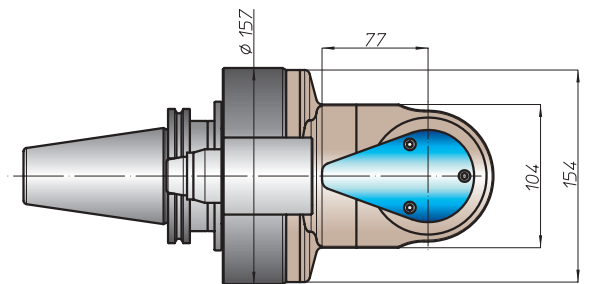
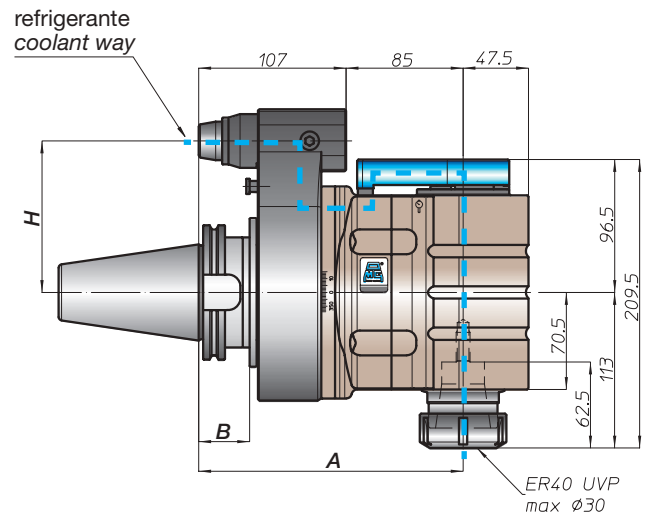
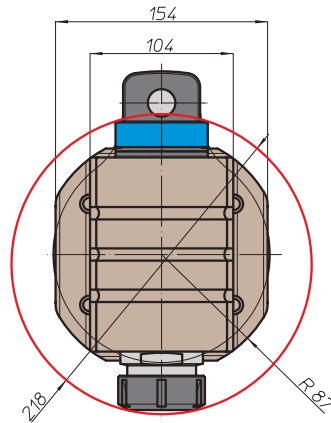

\* Option: Dual Contact



FH  
BAH  
TA.CP  
TA  
MO  
HT  
VH  
TSI/TSX  
T  
MT-TC-TC3  
Accessori  
Accessories  
Appendice tecnica  
Technical supplement

testa ad angolo - angle head

# TA26.40.D



caratteristiche/features



peso/weight



22 kg

rotazione/rotation



input



output

prestazioni/performance

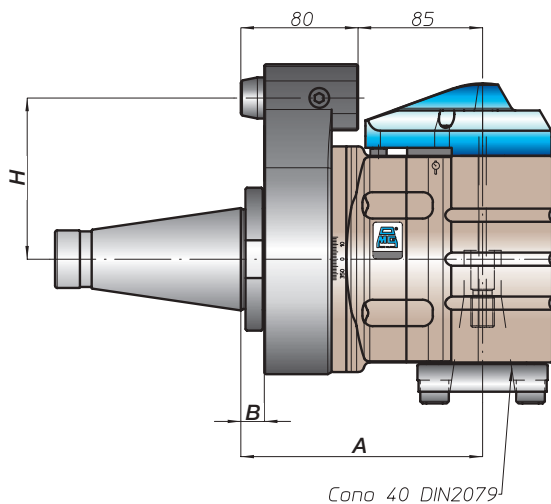
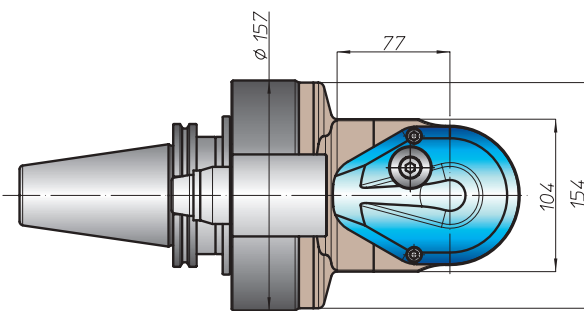
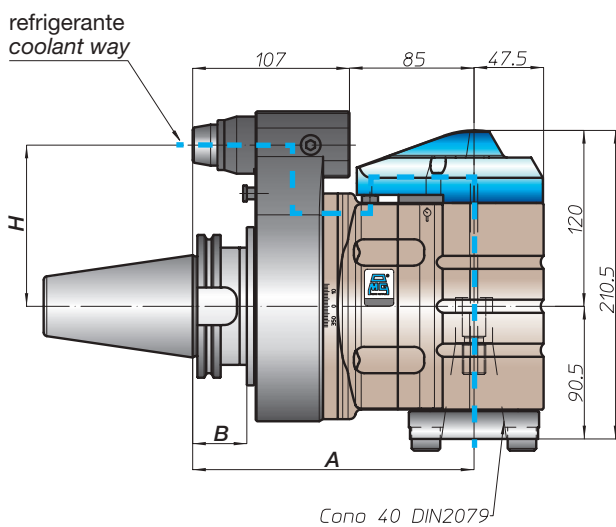
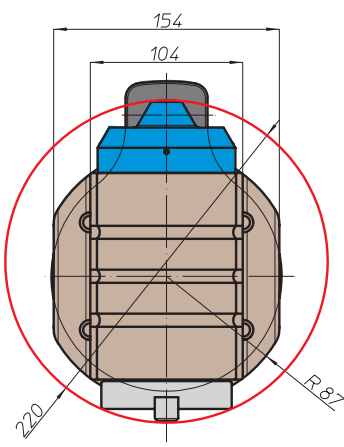
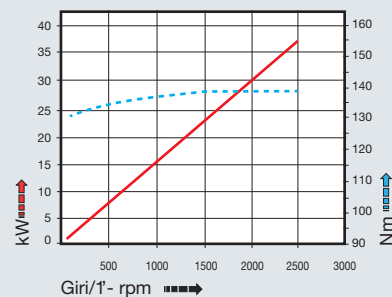

CONO SHANK	size	H		standard	optional
		A	B		
DIN69871 *	-	-	-	-	-
	45	-	-	110	-
	50	192	37	-	-
ANSIB5.50 *	-	-	-	-	-
	50	-	-	110	-
* BT	-	-	-	-	-
	50	200	45	110	-
HSK	-	-	-	-	-
DIN69893	80	-	-	110	-
	100	201	46	-	-
CAPTO	-	-	-	-	-
ISO26623	-	196	-	110	-
	C8	-	-	-	-
KM	-	-	-	-	-
	-	192	-	110	-
	100	-	-	-	-
DIN2080	-	-	-	-	-
	-	-	-	-	-
	50	165	16	110	-
NMTB	-	-	-	-	-
ANSIB5.18	50	165	16	110	-

\* Option: Dual Contact





FH

BAH

TA.CP

TA

MO

HT

VH

TSI/TSX

T

MT-TC-TC3

Accessori  
Accessories

Appendice tecnica  
Technical supplement



testa ad angolo - angle head

# TAO10.P

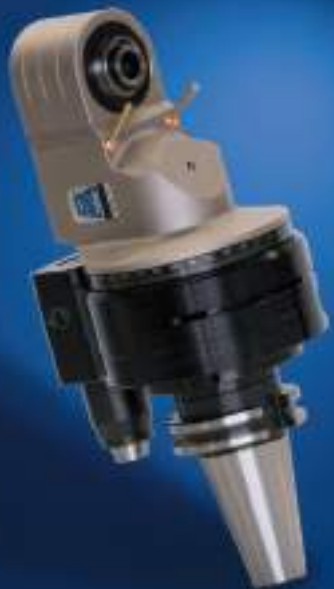

caratteristiche/features

ø 10    M8    500 N

1-1    6000

peso/weight

6,2 kg    8,7 kg

rotazione/rotation

input    output

prestazioni/performance

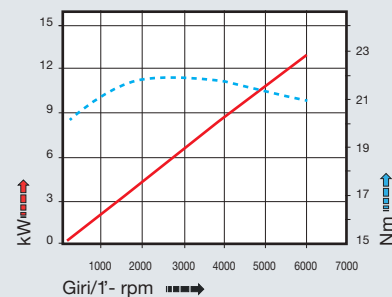

tipi mandrino disponibili / available spindle types

- 2** Albero portafresa / Milling shaft **Ø16**
- 4** DIN69893-HSK **HSK25**

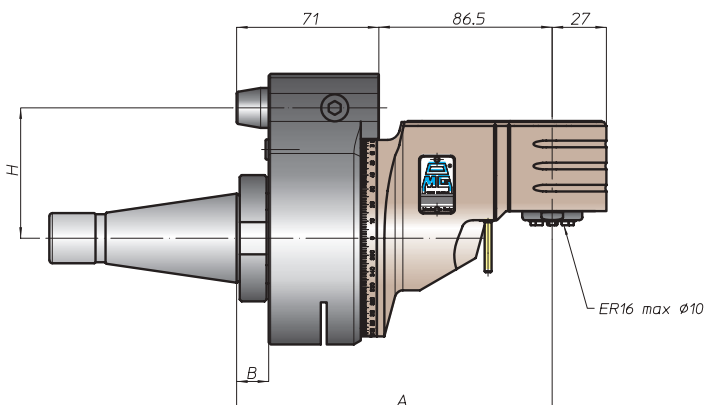
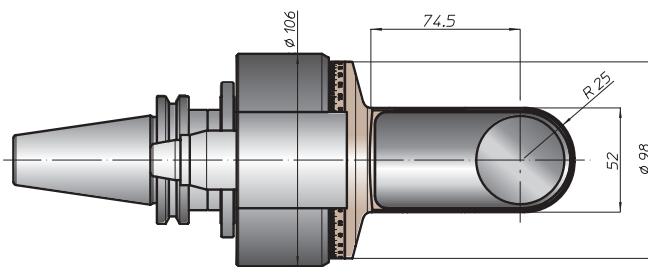
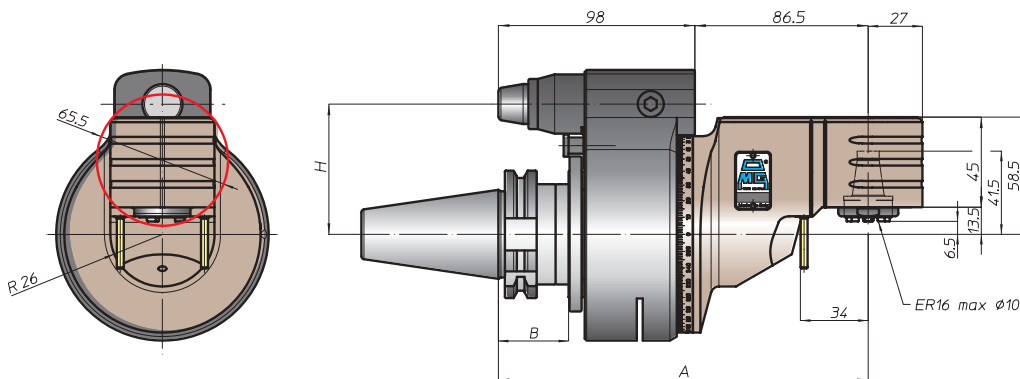

CONO SHANK	size	H		
		A	B	standard / optional
* DIN69871	-			
	40			65 -
	45			80 110
* CAT ANSIB5.50	50	184,5	35	
	40			65 -
	50			80 110
* BT	40			65
	50	192,5	45	80 110
HSK DIN69893	63		44	65
	80	193,5		80 110
	100		46	80 110
CAPTO ISO26623	C5			65
	C6	188,5	39	
	C8			80 110
KM	63			65
	80	184,5		80 110
	100			80 110
DIN2080	-	157,5	13	65 -
	40			
	50	160,5	16	80 110
ANSIB5.18 NMTB	40	157,5	13	65 -
	50	160,5	16	80 110

\* Option: Dual Contact



# TAO10.PD



caratteristiche/features

$\varnothing 10$  M8 500 N  
 1-1 6000 70 bar

peso/weight

40 6,2 kg  
 50 8,7 kg

rotazione/rotation

IN → OUT  
 input output

prestazioni/performance

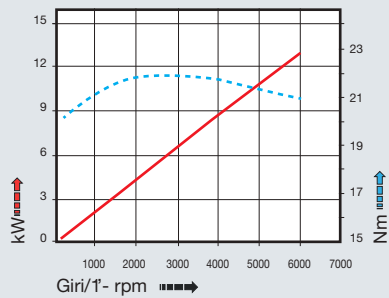

CONO SHANK	size	A	B	H	
				standard	optional
* DIN9871 *	-	184,5	35	65	-
	40			80	110
	45			80	110
* ANSIB5.50 * CAT	40	184,5	35	65	-
	50			80	110
* BT	40	192,5	45	65	-
	50			80	110
DIN9893 HSK	63	193,5	44	65	-
	80		46	80	110
	100		46	80	110
ISO26623 CAPTO	C5	188,5	39	65	-
	C6			80	110
	C8			80	110
KM	63	184,5	35	65	-
	80			80	110
	100			80	110
DIN2080	-	184,5	35	-	-
	-			-	-
	-			-	-
ANSIB5.18 NMTB	-	184,5	35	-	-
	-			-	-

tipi mandrino disponibili / available spindle types

2 Albero portafresa / Milling shaft  $\varnothing 16$   
4 DIN69893-HSK HSK25

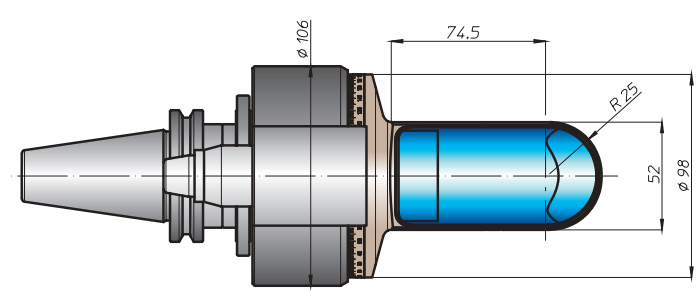
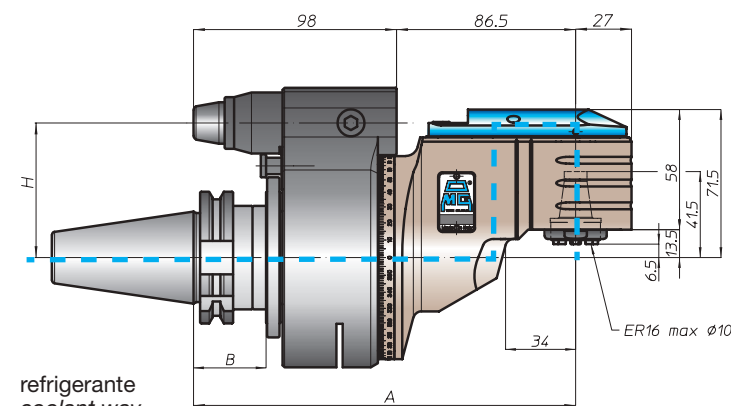
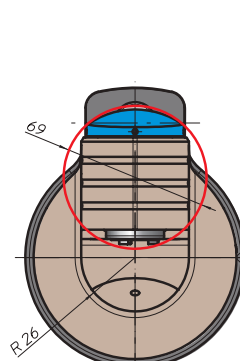

\* Option: Dual Contact



FH  
 BAH  
 TA.CP  
 TA  
 MO  
 HT  
 VH  
 TSI/TSX  
 T  
 MT-TC-TC3  
 Accessori / Accessories  
 Appendice tecnica / Technical supplement

testa ad angolo - angle head

# TA013.P



caratteristiche/features

ø 13    M10    570 N  
  
 1-1    4500

peso/weight

7,5 kg    10,5 kg

rotazione/rotation

→   
 input    output

prestazioni/performance

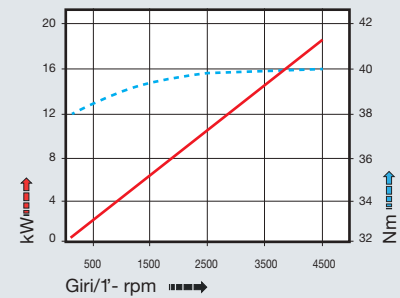

tipi mandrino disponibili / available spindle types

- 2** Albero portafresa  
Milling shaft  
Ø16
- 3** Weldon  
Whistle-Notch  
Ø12
- 4** DIN69893-HSK  
HSK32

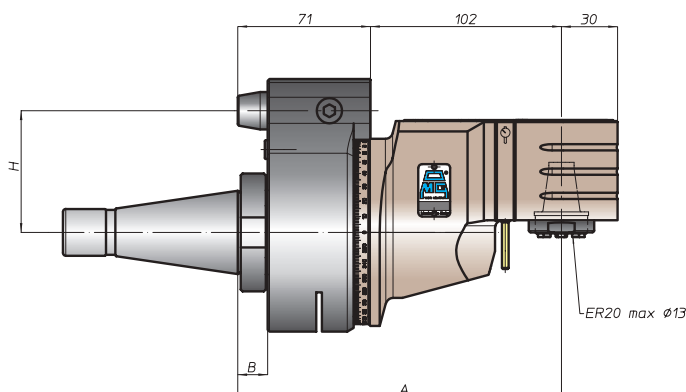
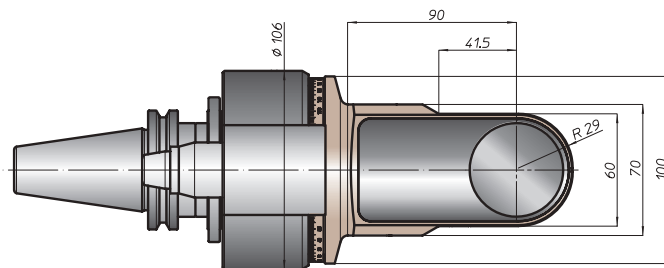
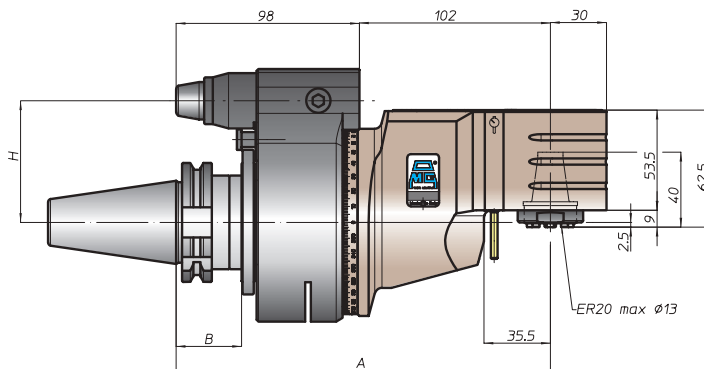
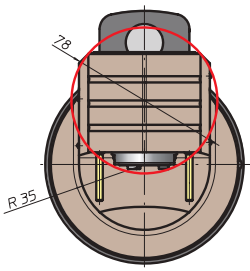

CONO SHANK	size	H			
		A	B	standard	optional
* DIN69871	-			65	-
	40			65	-
	45			80	110
* CAT	40	200	35	80	110
	50			80	110
	50			80	110
* BT	40			65	
	50	208	45	80	110
HSK	63			44	65
	80	209		46	80
	100			46	80
CAPTO	C5			65	
	C6	204	39	80	110
	C8			80	110
KM	63			65	
	80	200		80	110
	100			80	110
DIN2080	-	170	13	65	-
	40			65	-
	50	176	16	80	110
NMTB	40	173	13	65	-
	50	176	16	80	110

\* Option: Dual Contact





# TAO13.PD



caratteristiche/features

$\varnothing$  13    M10    570 N  
 1-1    4500    70 bar

peso/weight

7,5 kg    10,5 kg

rotazione/rotation

input    output

prestazioni/performance

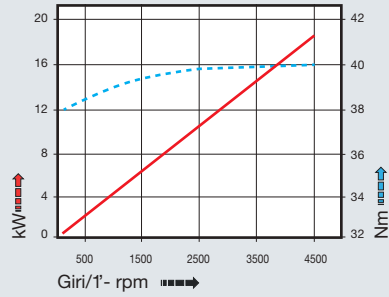

CONO SHANK	size	A	B	H	
				standard	optional
 DIN69871 *	-	200	35	65	-
	40			80	110
	45			80	110
 ANSIB5.50 *	40	208	45	65	-
	50			80	110
 * BT	40	208	45	65	-
	50			80	110
 DIN69893	63	209	44	65	-
	80		46	80	110
	100		46	80	110
 ISO26623	C5	204	39	65	-
	C6			80	110
	C8			80	110
 KM	63	200	-	65	-
	80			80	110
	100			80	110
 DIN2080	-	-	-	-	-
	-			-	-
	-			-	-
 ANSIB5.18	-	-	-	-	-
	-			-	-

tipi mandrino disponibili / available spindle types

2 Albero portafresa / Milling shaft   
 3 Weldon Whistle-Notch   
 4 DIN69893-HSK  
**Ø16                      Ø12                      HSK32**

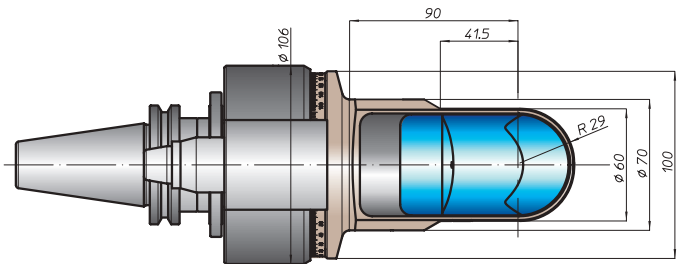
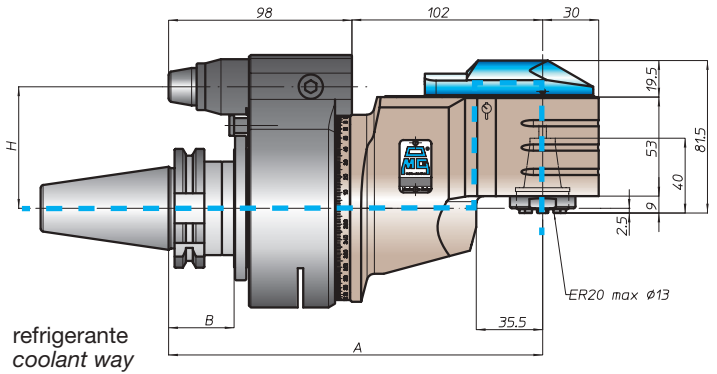
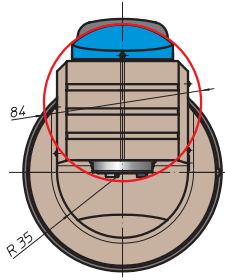

\* Option: Dual Contact



FH  
 BAH  
 TA.CP  
 TA  
 MO  
 HT  
 VH  
 TSI/TSX  
 T  
 MT-TC-TC3  
 Accessori  
 Accessories  
 Appendice tecnica  
 Technical supplement

testa ad angolo - angle head

# TAO16.P



caratteristiche/features

ø 16 M12 810 N

1-1 4000

peso/weight



14 kg

rotazione/rotation



input



output

prestazioni/performance

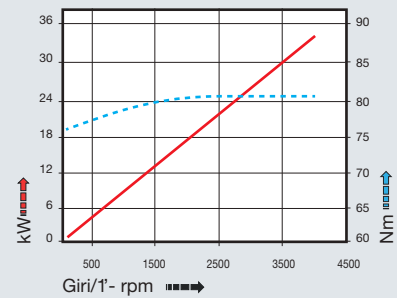

tipi mandrino disponibili / available spindle types

- 2** Albero portafresa  
Milling shaft  
Ø16-Ø22-Ø27
- 3** Weldon  
Whistle-Notch  
Ø16
- 4** DIN69893-HSK  
HSK40

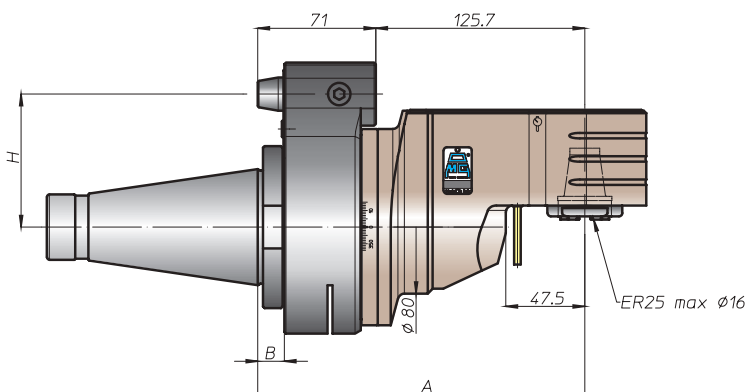
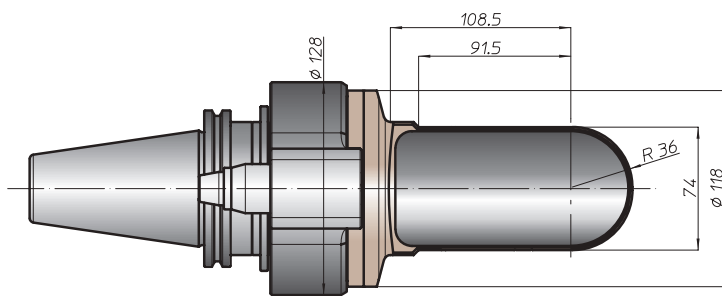
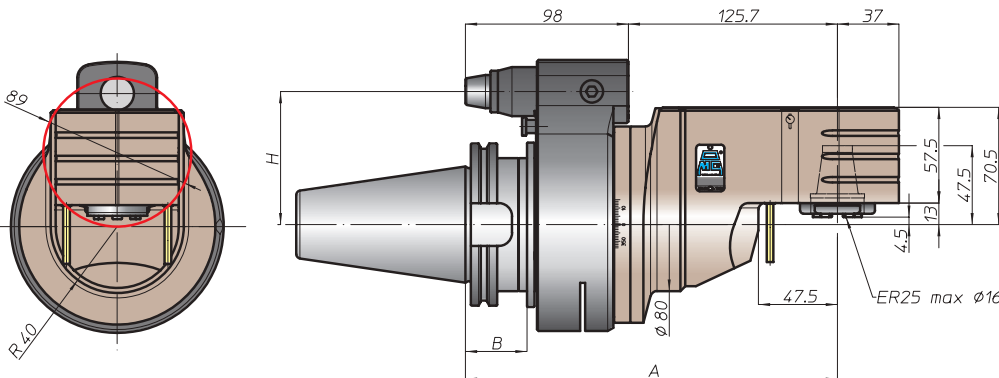

CONO SHANK	size	H			
		A	B	standard	optional
DIN69871 *	-	-	-	-	-
ANSI B5.50 *	45	223,5	35	80	110
	50			65	-
BT *	50	231,5	45	80	110
	50			65	-
HSK	80	232,5	46	80	110
	100			80	110
CAPTO	-	227,5	-	-	-
	C8			80	110
KM	80	223,5	-	-	-
	100			80	110
DIN2080	-	199,5	16	-	-
	50			80	110
ANSI B5.18 NMTB	-	199,5	16	-	-
	50			80	110

\* Option: Dual Contact



# TAO16.PD



caratteristiche/features

$\varnothing$  16    M12    810 N  
 1-1    4000    70 bar

peso/weight



rotazione/rotation



prestazioni/performance

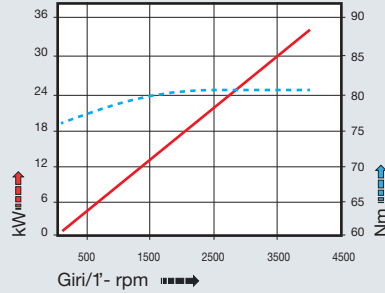

CONO SHANK	size	A	B	H	
				standard	optional
* DIN69871	-	223,5	35	-	-
	45			80	110
* CAT	-	223,5	35	65	-
	50			80	110
* BT	-	231,5	45	65	-
	50			80	110
HSK	-	232,5	46	-	-
	80			80	110
CAPTO	-	227,5	-	-	-
	C8			80	110
KM	-	223,5	-	-	-
	80			80	110
DIN2080	-	-	-	-	-
	-	-	-	-	-
NMTB	-	-	-	-	-
	-	-	-	-	-

tipi mandrino disponibili / available spindle types

- 2** Albero portafresa Milling shaft  
**Ø16-Ø22-Ø27**
- 3** Weldon Whistle-Notch  
**Ø16**
- 4** DIN69893-HSK  
**HSK40**

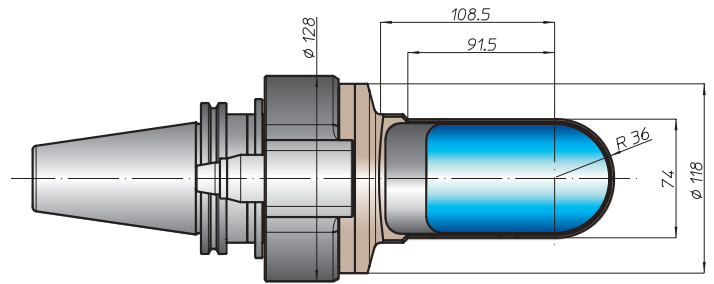
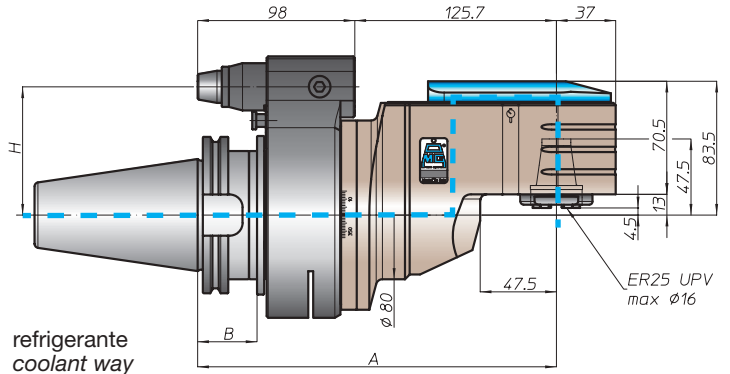
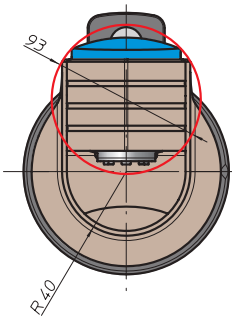

FH

BAH

TA.CP

TA

MO

HT

VH

TSI/TSX

T

MT-TC-TC3

Accessori Accessories

Appendice tecnica Technical supplement



\* Option: Dual Contact

testa ad angolo - angle head

# TAO20.P



caratteristiche/features

ø 20    M14    1150 N

1-1    3500

peso/weight

15 kg

rotazione/rotation

→ 
  
 input    output

prestazioni/performance

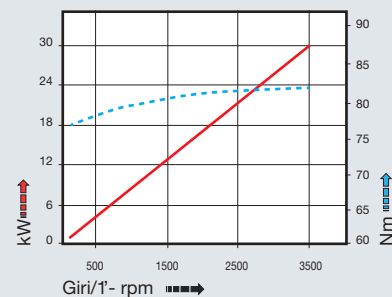

tipi mandrino disponibili / available spindle types

- 2** Albero portafresa  
Milling shaft  
Ø22-Ø27-Ø32
- 3** Weldon  
Whistle-Notch  
Ø16-Ø20
- 4** DIN69893-HSK  
HSK50

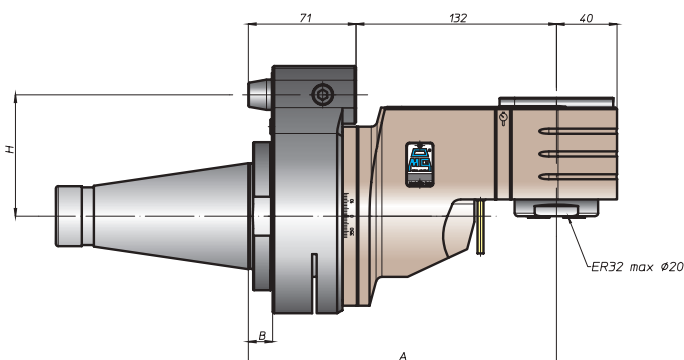
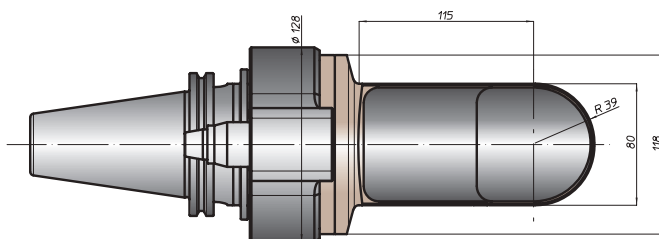
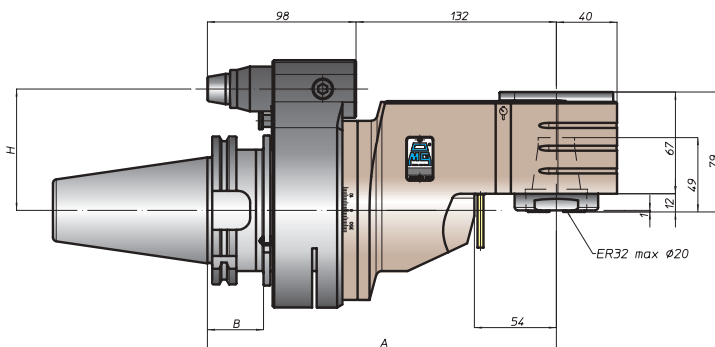
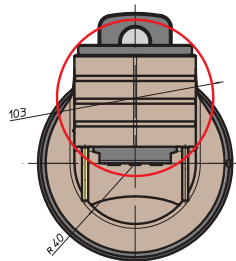

CONO SHANK	size	H			
		A	B	standard	optional
DIN69871 *	-	-	-	-	-
ANSI B5.50 *	45	230	35	80	110
	50			80	110
BT *	-	-	-	65	-
	50	238	45	80	110
HSK	-	-	-	-	-
	DIN69893	80	239	46	80
CAPTO	-	234	-	-	-
	ISO28623			-	80
KM	-	230	-	-	-
	80			80	110
DIN2080	-	203	16	-	-
	50			80	110
ANSI B5.18 NMTB	-	203	16	-	-
	50			80	110

\* Option: Dual Contact



# TAO20.PD



caratteristiche/features

$\varnothing$  20    M14    1150 N  
 1-1    3500    70 bar

peso/weight



15 kg

rotazione/rotation



input



output

prestazioni/performance

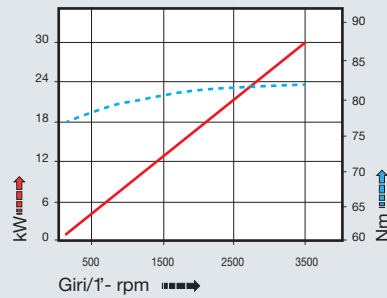

CONO SHANK	size	A	B	H	
				standard	optional
* DING9871	-	230	35	-	-
	45			80	110
* CAT ANSIB5.50	-	234	46	80	110
	50			80	110
* BT	-	234	46	65	-
50	238			45	80
HSK DING9893	-	239	46	42	-
	80			80	110
CAPTO ISO26623	-	234	46	80	110
	100			80	110
KM	-	230	35	-	-
	80			80	110
100	-	234	46	-	-
	80			80	110
DIN2080	-	234	46	-	-
	-			-	-
ANSIB5.18 NMTB	-	234	46	-	-
	-			-	-

tipi mandrino disponibili / available spindle types

- 2** Albero portafresa Milling shaft    **3** Weldon Whistle-Notch    **4** DIN69893-HSK
- Ø22-Ø27-Ø32**    **Ø16-Ø20**    **HSK50**

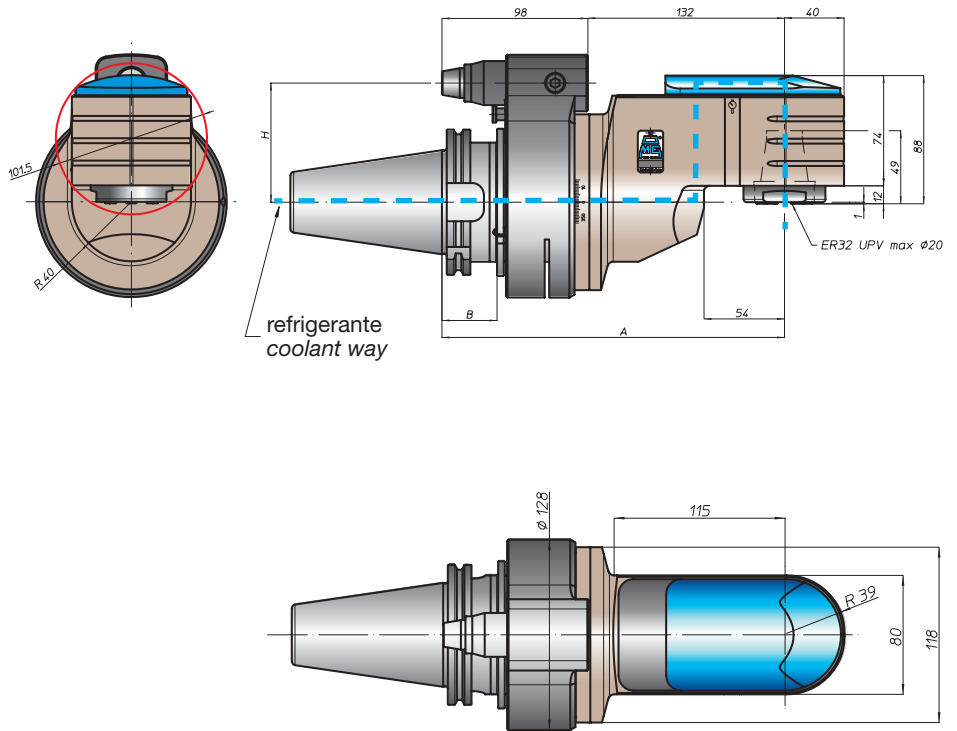

FH  
 BAH  
 TA.CP  
 TA  
 MO  
 HT  
 VH  
 TSI/TSX  
 T  
 MT-TC-TC3  
 Accessori  
 Accessories  
 Appendice tecnica  
 Technical supplement

\* Option: Dual Contact



testa ad angolo - angle head

# TAO26.P



caratteristiche/features

$\phi$  26    M20    1590 N

1-1    3000

peso/weight

24 kg

rotazione/rotation

input    output

prestazioni/performance

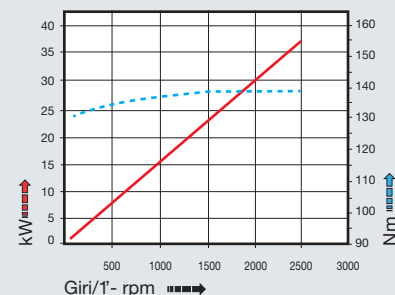

tipi mandrino disponibili / available spindle types

- 2** Albero portafresa  
Milling shaft
  - 3** Weldon  
Whistle-Notch
  - 4** DIN69893-HSK
- $\phi$ 22- $\phi$ 27- $\phi$ 32     $\phi$ 16- $\phi$ 20    HSK63

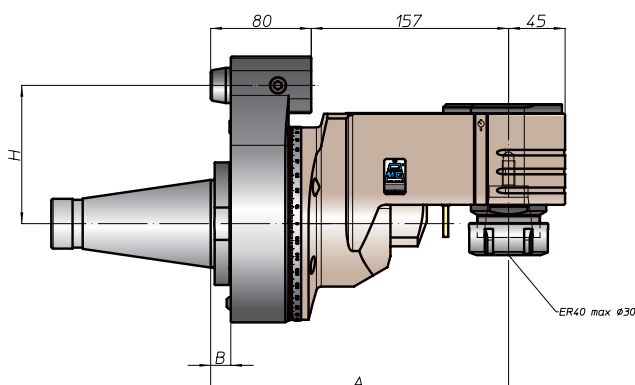
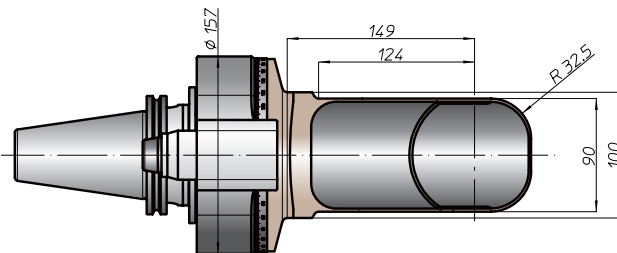
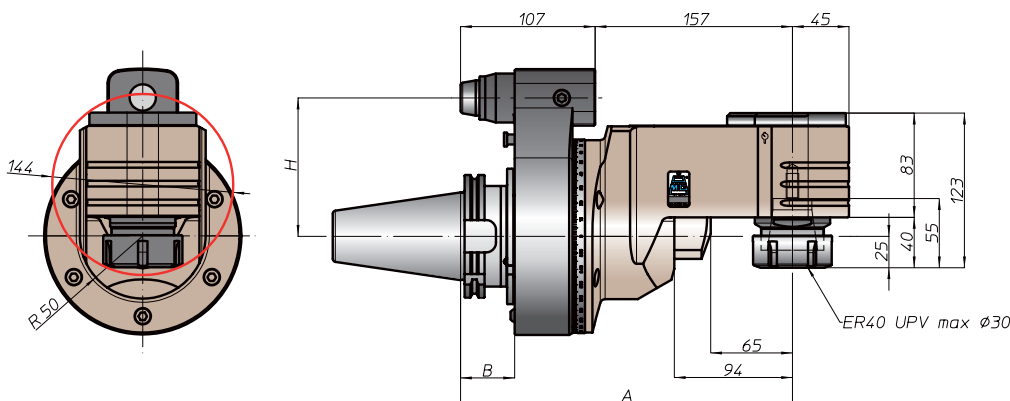

CONO SHANK	size	H			
		A	B	standard	optional
DIN69871 *	-	-	-	-	-
ANSI B5.50 *	50	270	35	110	-
BT	50	-	-	110	-
HSK	100	279	46	110	-
CAPTO	C8	274	-	110	-
KM	100	270	-	110	-
DIN2080	50	243	16	110	-
NMTB	50	243	16	110	-

\* Option: Dual Contact



# TAO26.PD



caratteristiche/features

$\varnothing$  26    M20    1590 N  
 1-1    3000    70 bar

peso/weight









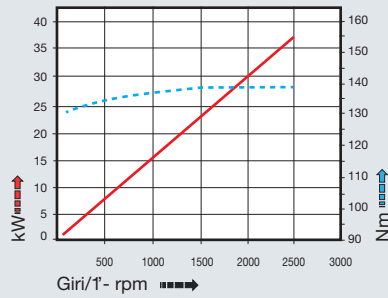

24 kg

rotazione/rotation



prestazioni/performance



CONO SHANK	size	A	B	H	
				standard	optional
DIN69871 *	-	-	-	-	-
	-	-	-	-	-
	50	270	35	110	-
ANSIB5.50 CAT	-	-	-	-	-
	50	-	-	110	-
BT	-	-	-	-	-
	50	278	45	110	-
HSK	-	-	-	-	-
	100	279	46	110	-
CAPTO	-	-	-	-	-
	C8	274	-	110	-
KM	-	-	-	-	-
	100	270	-	110	-
DIN2080	-	-	-	-	-
	-	-	-	-	-
NMTB	-	-	-	-	-
	-	-	-	-	-

tipi mandrino disponibili / available spindle types

- 2** Albero portafrese  
Milling shaft  
**Ø22-Ø27-Ø32**
- 3** Weldon  
Whistle-Notch  
**Ø16-Ø20**
- 4** DIN69893-HSK  
**HSK63**

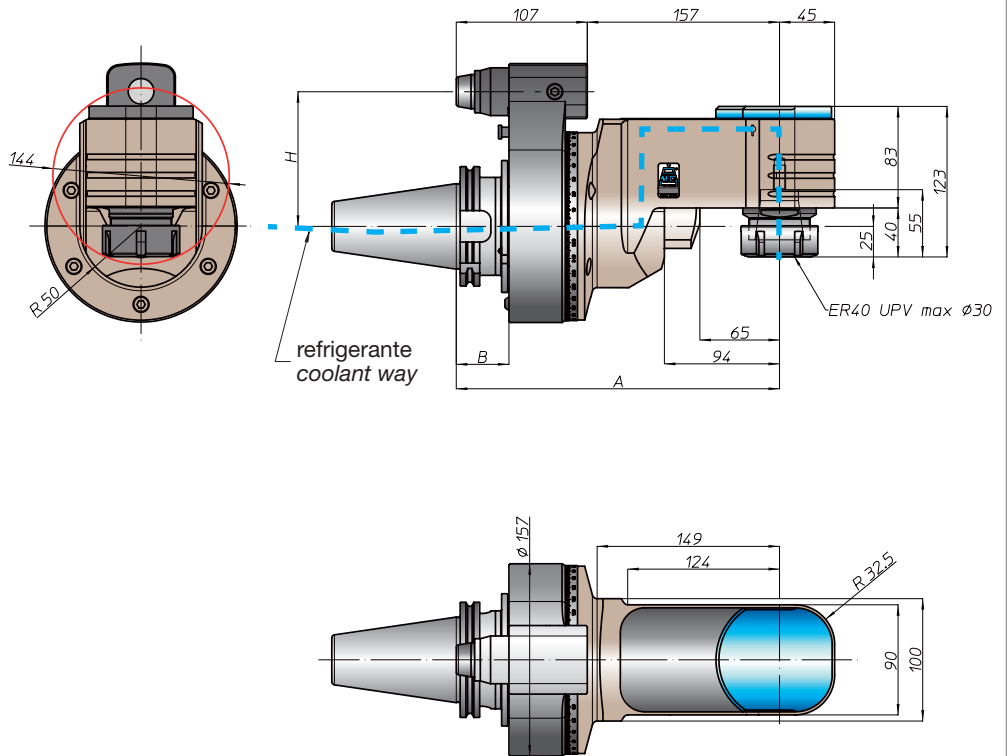

\* Option: Dual Contact



FH  
 BAH  
 TA.CP  
 TA  
 MO  
 HT  
 VH  
 TSI/TSX  
 T  
 MT-TC-TC3  
 Accessori  
 Accessories  
 Appendice tecnica  
 Technical supplement

# TAV

## DIGITAL



### **Nuovo standard nelle teste ad angolo variabile.**

La serie TAV si propone ora con un display per la visualizzazione dell'inclinazione del mandrino. La facilità di utilizzo, la precisione del sistema, l'ingombro estremamente ridotto consentirà agli utenti di registrare direttamente in macchina l'angolo della lavorazione che la Testa ad Angolo Variabile deve eseguire sul pezzo in modo semplice ed efficace.

Oggi sono disponibili i tre principali modelli di Teste ad Angolo Variabile: TAV10, TAV13 e TAV20.

Lo sviluppo di questa soluzione verterà presto trasportata a tutta la famiglia delle Teste ad Angolo della serie TAV.

### **New standard system on TAV adjustable angle heads.**

*The TAV series is now being enhanced with a display to check the spindle angle inclination. Both the user-friendliness and the precision, as well as the extremely reduced footprint of this new system, will allow the users to easily and effectively set the adjustable angle head directly on the machine prepared to machine pieces.*

*Nowadays the three major adjustable angle head models are available: TAV10, TAV13 and TAV20.*

*And this new solution will be soon available on the whole range of TAV angle heads.*







testa ad angolo - angle head

# TAV10.P



caratteristiche/features

peso/weight

prestazioni/performances

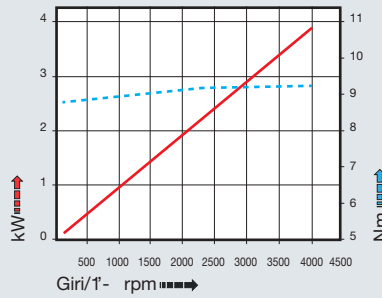
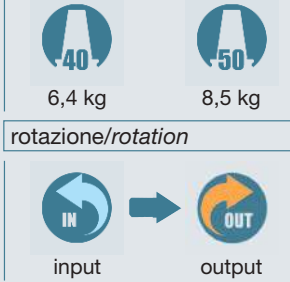

CONO SHANK	size	A		B		H	
		standard	optional	standard	optional	standard	optional
DIN69871 *	40	140	35	65	-	80	110
	45			80	110		
	50			80	110		
ANSIB5.50 *	40	148	45	65	-	80	110
	50			80	110		
BT *	40	148	45	65	-	80	110
	50			80	110		
HSK	63	149	46	65	-	80	110
	80			80	110		
	100			80	110		
CAPTO	C5	144	39	65	-	80	110
	C6			80	110		
	C8			80	110		
KM	63	140	-	65	-	80	110
	80			80	110		
	100			80	110		
DIN2080	40	113	13	65	-	80	110
	50			80	110		
	50			116	16		
ANSIB5.18 NMTB	40	113	13	65	-	80	110
	50			116	16		

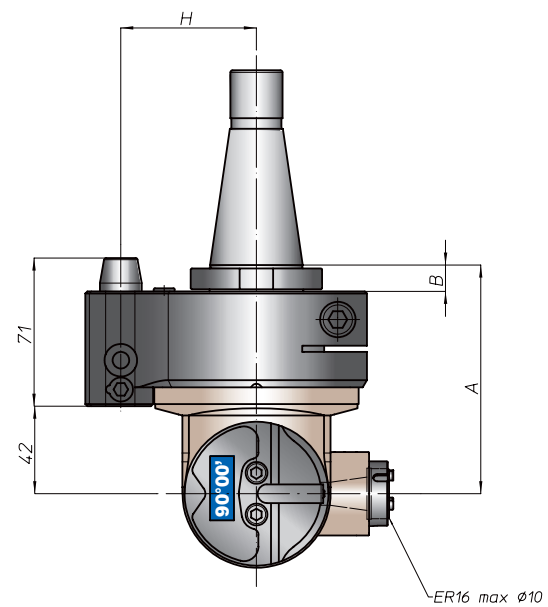
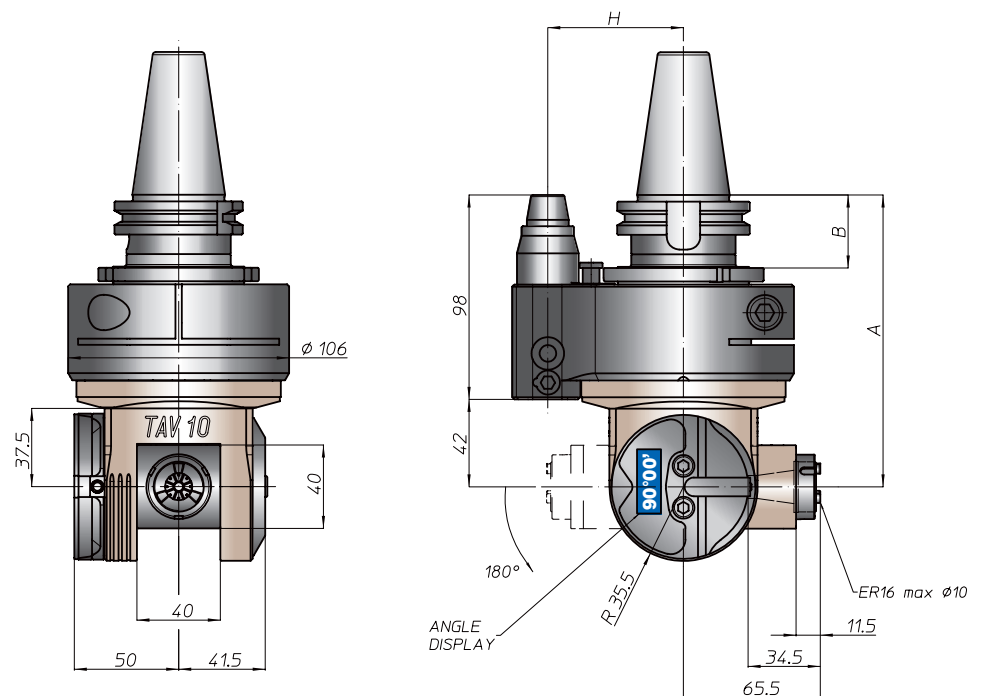

\* Option: Dual Contact



FH  
BAH  
TA.CP  
TA  
MO  
HT  
VH  
TSI/TSX  
T  
MT-TC-TC3  
Accessori  
Accessories  
Appendice tecnica  
Technical supplement

# TAV13.P



caratteristiche/features

ø 13   
 M10   
 630 N  
 1-1   
 5500

peso/weight

40  
7,8 kg   
 50  
10,5 kg

rotazione/rotation

IN input   
 OUT output

prestazioni/performance

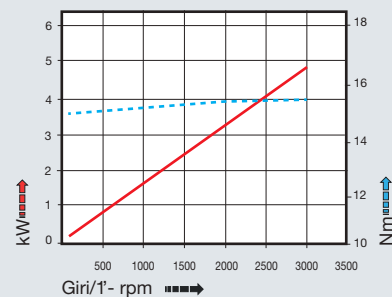

tipi mandrino disponibili / available spindle types

- 1** DIN6388-ER ER25
- 3** Weldon Whistle-Notch Ø16

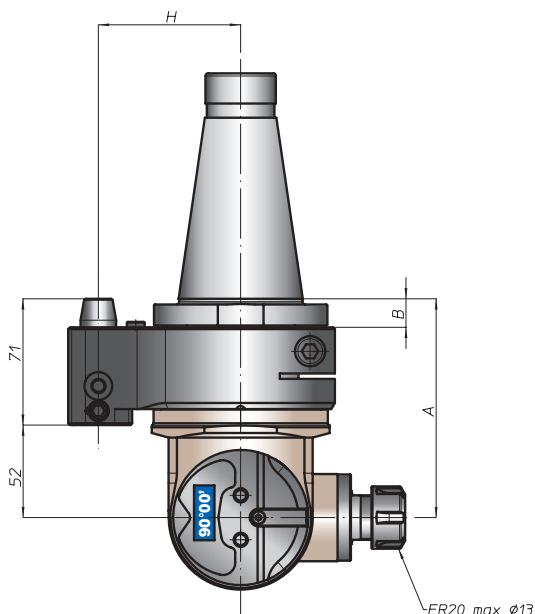
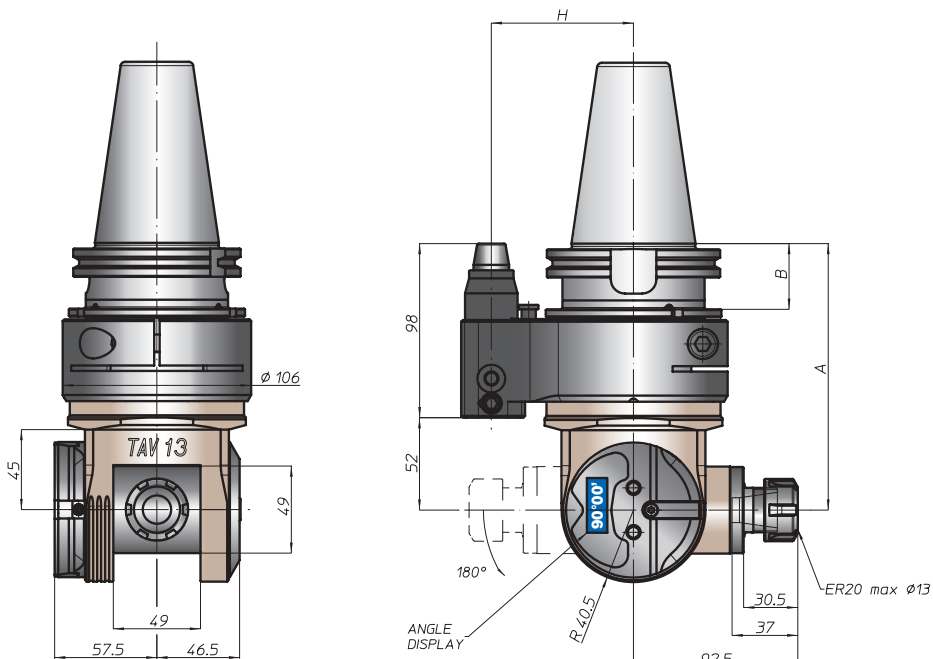

CONO SHANK	size	H			
		A	B	standard	optional
* DING9871	-			65	-
	40	150	35	80	110
	45				
50					
* ANSIB5.50 CAT	40			65	-
	50			80	110
* BT	40			65	
	50	158	45	80	110
DING9893 HSK	63		42	65	
	80	159		46	80 110
	100				
ISO28623 CAPTO	C5			65	
	C6	154	39		
	C8			80	110
KM	63			65	
	80	150			
	100			80	110
DIN2080	-	120	13	65	-
	40				
	-	123	16	80	110
ANSIB5.18 NMTB	40	120	13	65	-
	50	123	16	80	110

\* Option: Dual Contact



# TAV20.P



caratteristiche/features

peso/weight

prestazioni/performances



rotazione/rotation

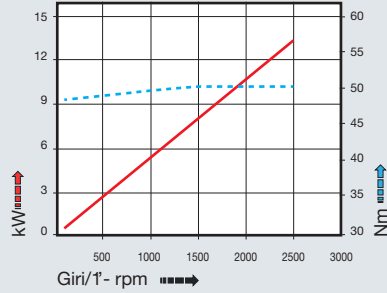

CONO SHANK	size	A	B	H	
				standard	optional
DIN69871	-	173	35	-	-
	50			110	-
ANSIB5.50	-	177	-	-	-
	50			110	-
BT	-	181	45	110	-
	50			-	-
HSK	-	182	46	110	-
	80			-	-
DIN69893	-	177	-	110	-
	100			-	-
CAPTO	-	177	-	110	-
	C8			-	-
KM	-	173	-	110	-
	100			-	-
DIN2080	-	149	16	110	-
	50			-	-
ANSIB5.18	-	149	16	110	-
	50			-	-

tipi mandrino disponibili / available spindle types

- 1 DIN6388-ER  
**ER40**
- 2 Albero portafresa  
Milling shaft  
**Ø32**
- 3 Weldon  
Whistle-Notch  
**Ø20-Ø25**
- 4 DIN69893-HSK  
**HSK50**
- 6 ABS  
Licenza KOMET®  
**ABS50**

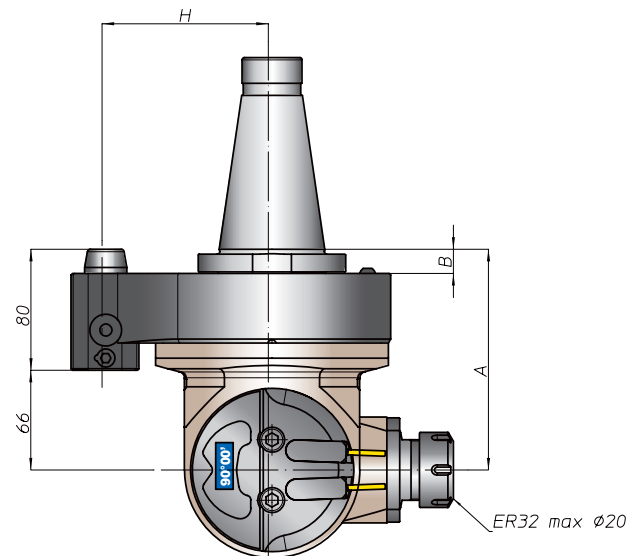
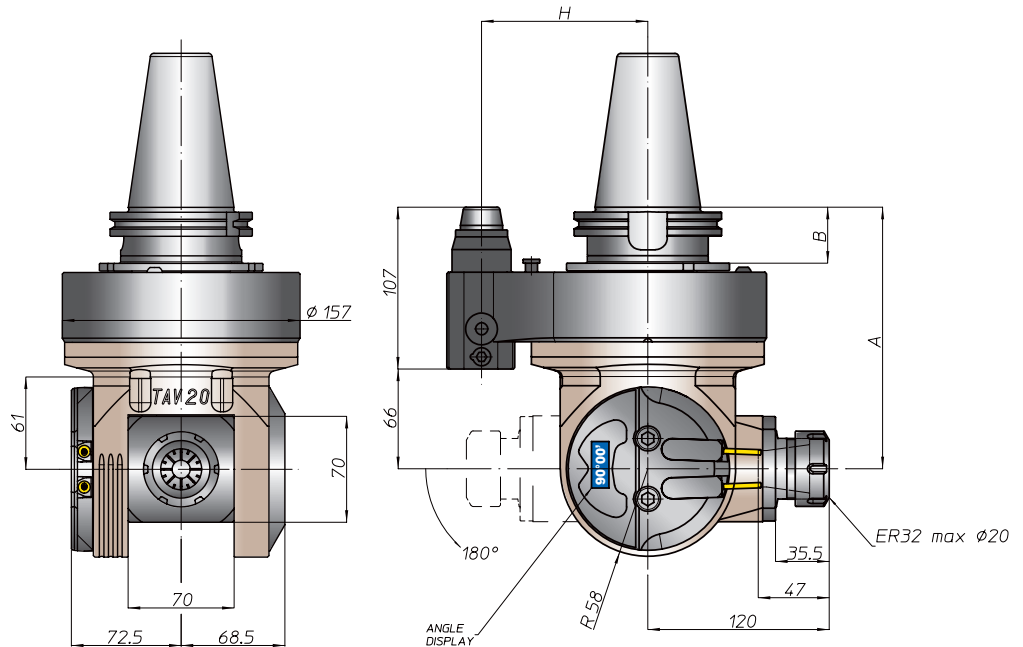

★ Option: Dual Contact



FH  
BAH  
TA.CP  
TA  
MO  
HT  
VH  
TSI/TSX  
T  
MT-TC-TC3  
Accessori  
Accessories  
Appendice tecnica  
Technical supplement



testa ad angolo - angle head

# TAV10.P



caratteristiche/features



  
 ø 10    M8    550 N

  
 1-1    8000

peso/weight

  
 6,4 kg    8,5 kg

rotazione/rotation

  
 input    output

prestazioni/performance

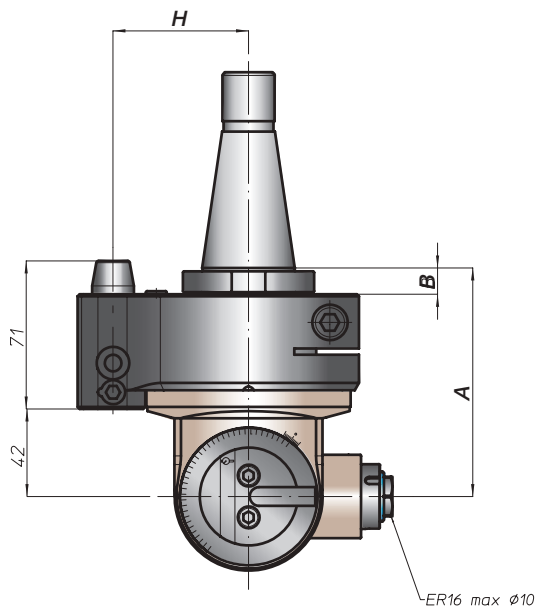
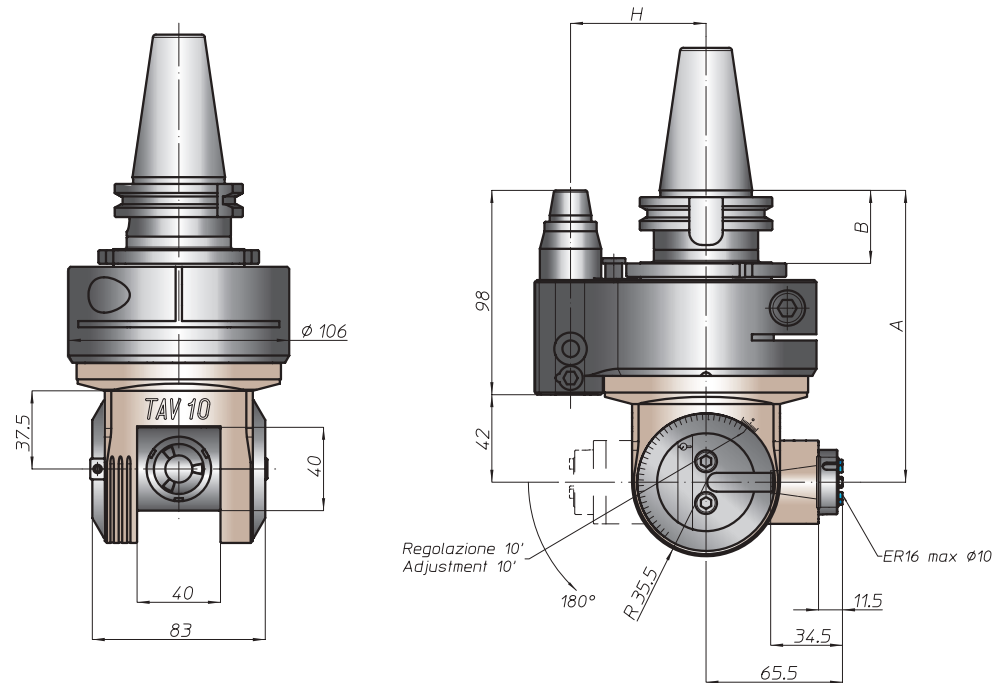
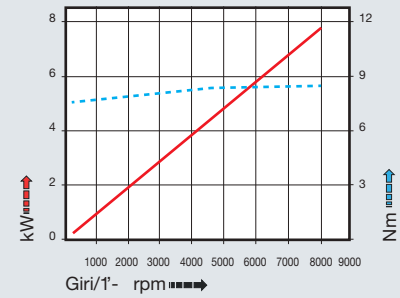

CONO SHANK	size	H			
		A	B	standard	optional
* DIN9871	40	140	35	65	-
	45			80	110
	50			80	110
* CAT ANSIB5.50	40	148	45	65	-
	50			80	110
* BT	40	148	45	65	-
	50			80	110
HSK DIN9893	63	149	46	44	65
	80			80	110
	100			80	110
CAPTO ISO26623	C5	144	39	65	-
	C6			80	110
	C8			80	110
KM	63	140	80	65	-
	80			80	110
	100			80	110
DIN2080	40	113	13	65	-
	50			80	110
	50			116	16
ANSIB5.18 NMTB	40	113	13	65	-
	50			116	16

\* Option: Dual Contact





# TAV10.PD



caratteristiche/features

peso/weight

prestazioni/performances

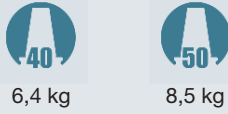
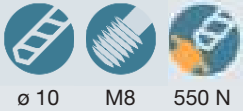

rotazione/rotation

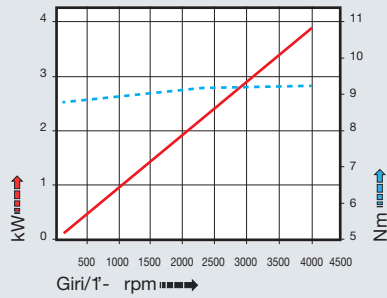
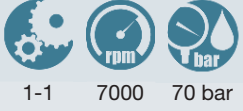

CONO SHANK	size	A	B	H	
				standard	optional
* DIN9871 *	-	140	35	65	-
	40			80	110
	45			80	110
* ANSIB5.50 * CAT	40	148	45	65	-
	50			80	110
* BT	40	148	45	65	-
	50			80	110
DIN9893 HSK	63	149	44	65	-
	80		46	80	110
	100		46	80	110
ISO26623 CAPTO	C5	144	39	65	-
	C6			80	110
	C8			80	110
KM	63	140	-	65	-
	80			80	110
	100			80	110
DIN2080	-	-	-	-	-
	-	-	-	-	-
	-	-	-	-	-
ANSIB5.18 NMTB	-	-	-	-	-
	-	-	-	-	-

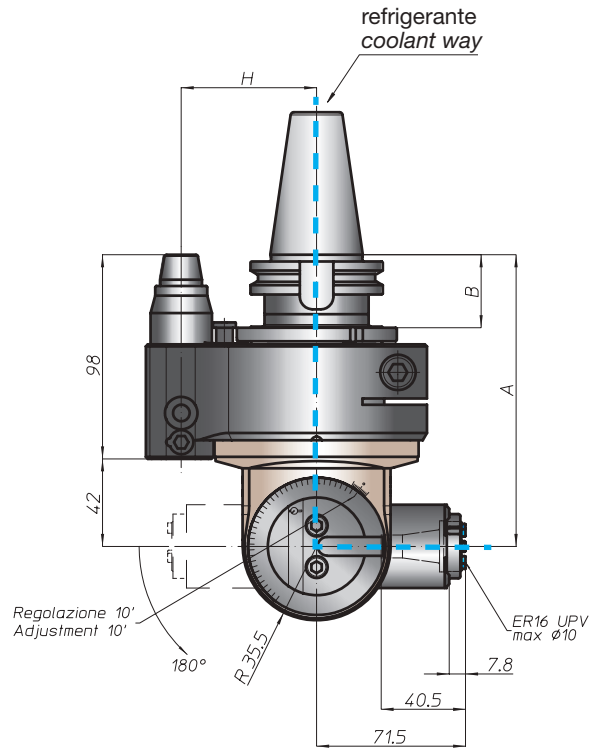
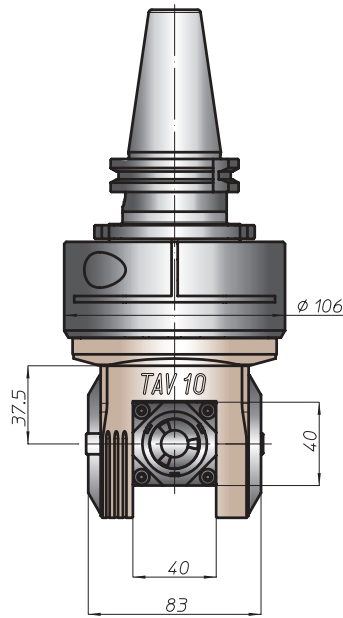

\* Option: Dual Contact





testa ad angolo - *angle head*

# TAV13.P

caratteristiche/features



peso/weight

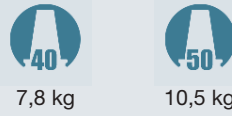

rotazione/rotation



prestazioni/performance

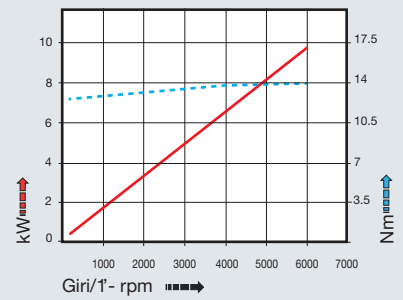

tipi mandrino disponibili / available spindle types

- 1** DIN6388-ER ER25
- 3** Weldon Whistle-Notch Ø16

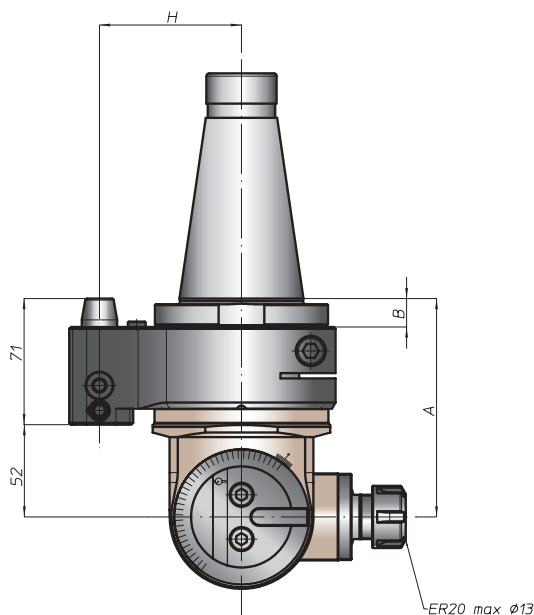
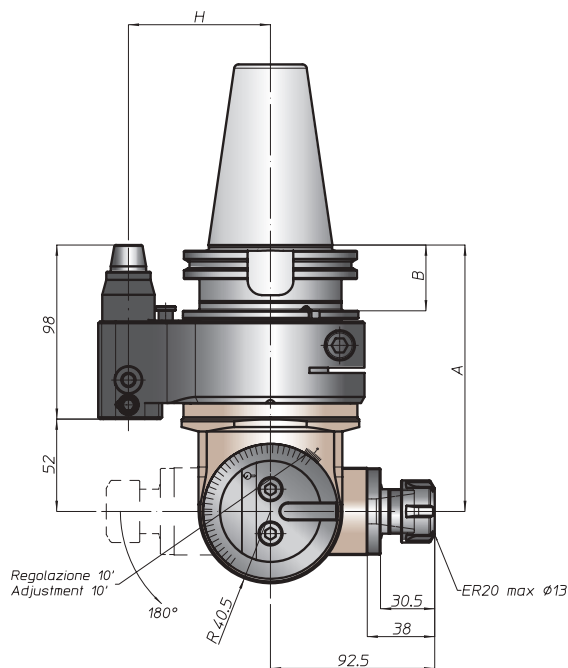
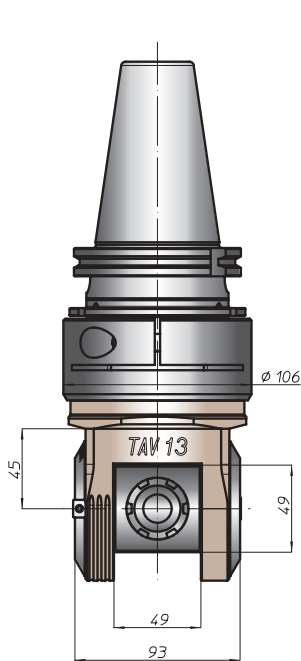

CONO SHANK	size	H			
		A	B	standard	optional
* DIN69871	-			65	-
	40	150	35	80	110
	45				
50					
* CAT ANSIB5.50	40			65	-
	50			80	110
* BT	40			65	
	50	158	45	80	110
HSK DIN69893	63		42	65	
	80	159		80	110
	100		46	80	110
CAPTO ISO26623	C5			65	
	C6	154	39		
	C8			80	110
KM	63			65	
	80	150			
	100			80	110
DIN2080	-	120	13	65	-
	40				
	-	123	16	80	110
ANSIB5.18 NMTB	40	120	13	65	-
	50	123	16	80	110

\* Option: Dual Contact





# TAV13.PD



caratteristiche/features

$\varnothing$  13    M10    630 N  
 1-1    5500    70 bar

peso/weight

7,8 kg    10,5 kg

rotazione/rotation

input    output

prestazioni/performance

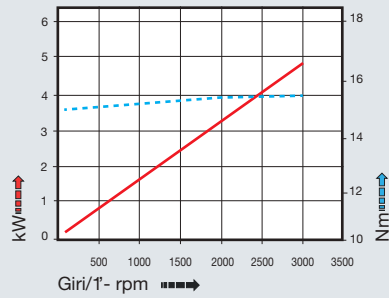

CONO SHANK	size	A	B	H	
				standard	optional
* DIN69871 *	-			65	-
	40			80	110
	45	150	35	80	110
* CAT	40			65	-
	50			80	110
* BT	40			65	-
	50	158	45	80	110
DIN69893	63		42	65	-
	80	159		80	110
	100		46	80	110
CAPTO	C5			65	-
	C6	154	39	80	110
	C8			80	110
KM	63			65	-
	80	150		80	110
	100			80	110
DIN2080	-	120	13	65	-
	40			-	-
	-	-	-	-	-
NMTB	-	-	-	-	-
	-	-	-	-	-

tipi mandrino disponibili / available spindle types

1 DIN6388-ER    3 Weldon Whistle-Notch  
**ER25**    **Ø16**

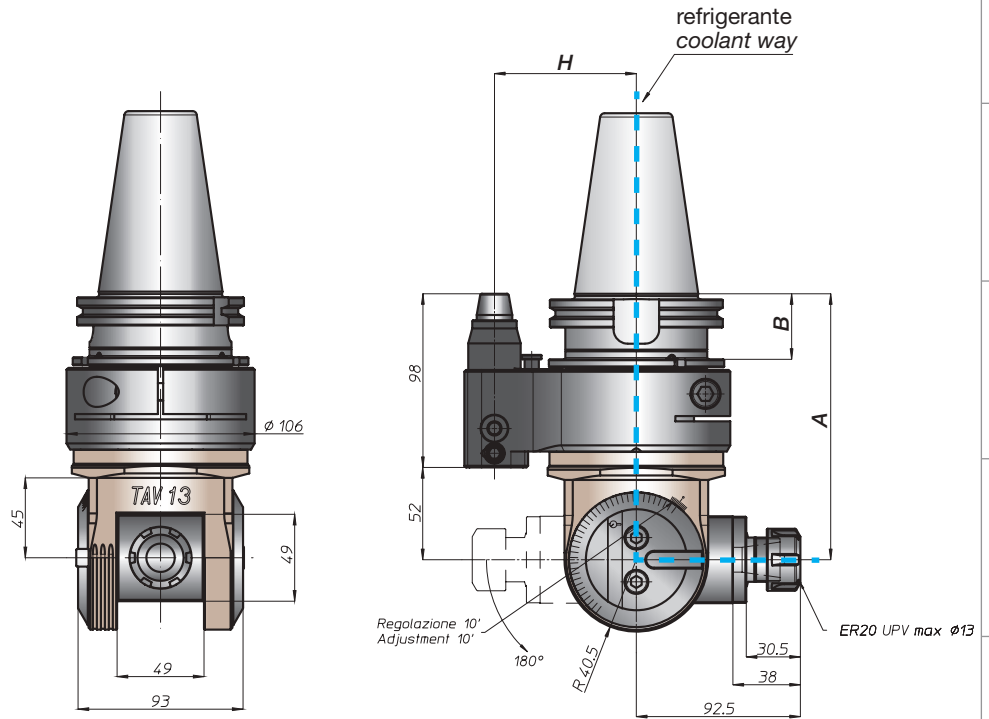

\* Option: Dual Contact

FH

BAH

TA.CP

TA

MO

HT

VH

TSI/TSX

T

MT-TC-TC3

Accessori  
Accessories

Appendice tecnica  
Technical supplement





testa ad angolo - angle head

# TAV20.P



caratteristiche/features



  
 ø 20    M16    1740 N  

  
 1-1    4000

peso/weight



22 kg

rotazione/rotation



input



output

prestazioni/performance

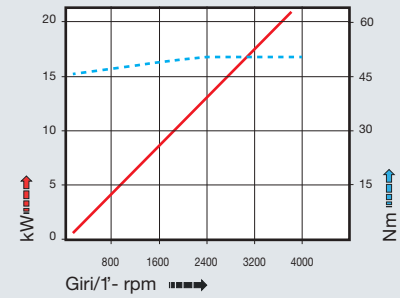

tipi mandrino disponibili / available spindle types

- 1** DIN6388-ER  
ER40
- 2** Albero portafresa  
Milling shaft  
Ø32
- 3** Weldon  
Whistle-Notch  
Ø20-Ø25
- 4** DIN69893-HSK  
HSK50
- 6** ABS  
Licenza KOMET®  
ABS50

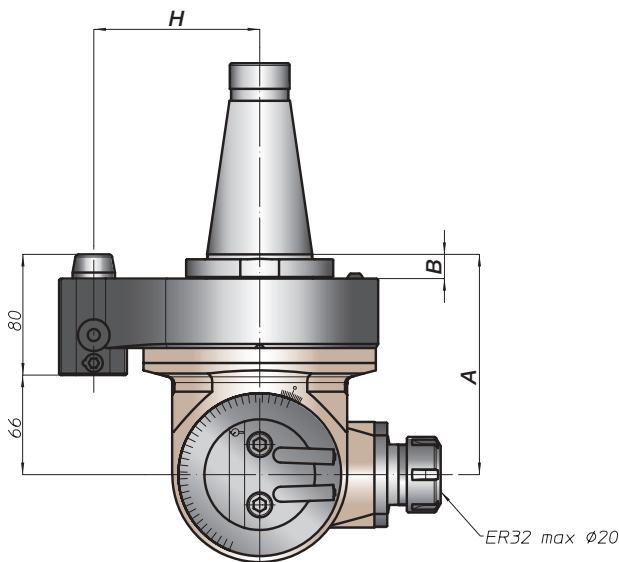
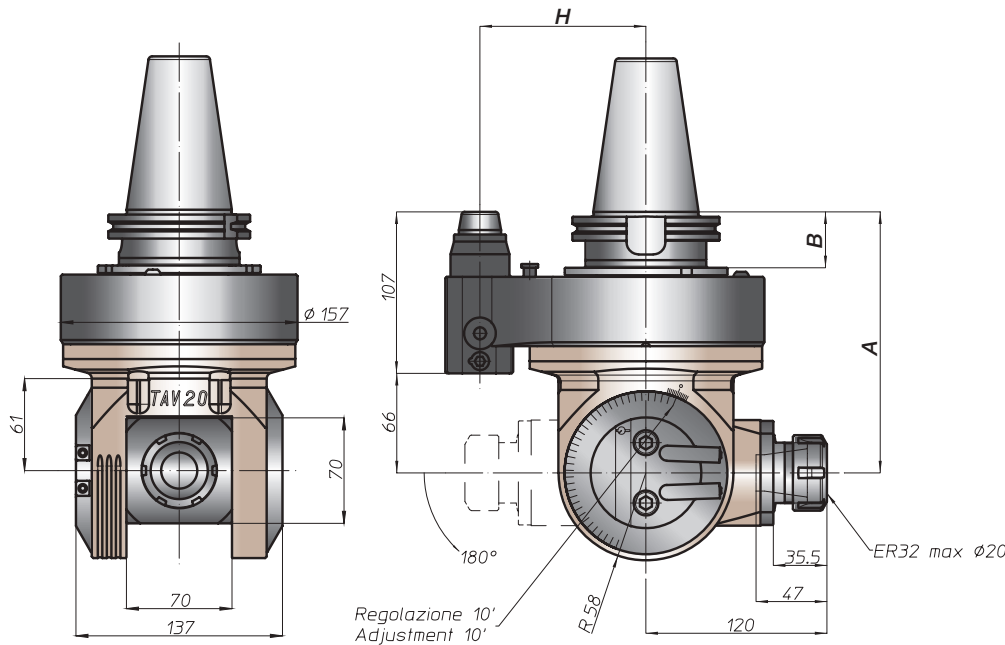

CONO SHANK	size	H			
		A	B	standard	optional
DIN69871 *	-	-	-	-	-
ANSIB5.50 *	50	173	35	110	-
	CAT	-	-	-	-
BT *	50	181	45	110	-
	HSK	-	-	-	-
DIN69893	80	182	46	110	-
	100	-	-	-	-
CAPTO	-	-	-	-	-
	ISO28623	177	-	110	-
KM	-	-	-	-	-
	100	173	-	110	-
DIN2080	-	-	-	-	-
	50	149	16	110	-
NMTB	-	-	-	-	-
	ANSIB5.18	50	149	16	110

\* Option: Dual Contact







# TAV20.PD



caratteristiche/features

ø 20 M16 1740 N

1-1 4000 70 bar

peso/weight

22 kg

rotazione/rotation

input output

prestazioni/performance

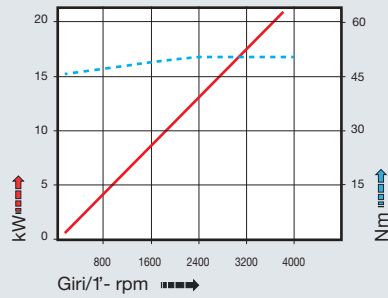

CONO SHANK	size	A	B	H	
				standard	optional
DIN69871 *	-	-	-	-	-
	50	173	35	110	-
ANSIB5.50 *	-	-	-	-	-
	50	-	-	110	-
BT *	-	-	-	-	-
	50	181	45	110	-
HSK	-	-	-	-	-
DIN69893	80	182	-	110	-
	100	-	46	110	-
CAPTO	-	-	-	-	-
ISO26623	-	177	-	110	-
	C8	-	-	-	-
KM	-	-	-	-	-
	100	173	-	110	-
DIN2080	-	-	-	-	-
	-	-	-	-	-
NMTB	-	-	-	-	-
ANSIB5.18	-	-	-	-	-

tipi mandrino disponibili / available spindle types

**1** DIN6388-ER **3** Weldon Whistle-Notch **4** DIN69893-HSK **6** ABS Licenza KOMET®  
**ER40** **Ø20-Ø25** **HSK50** **ABS50**

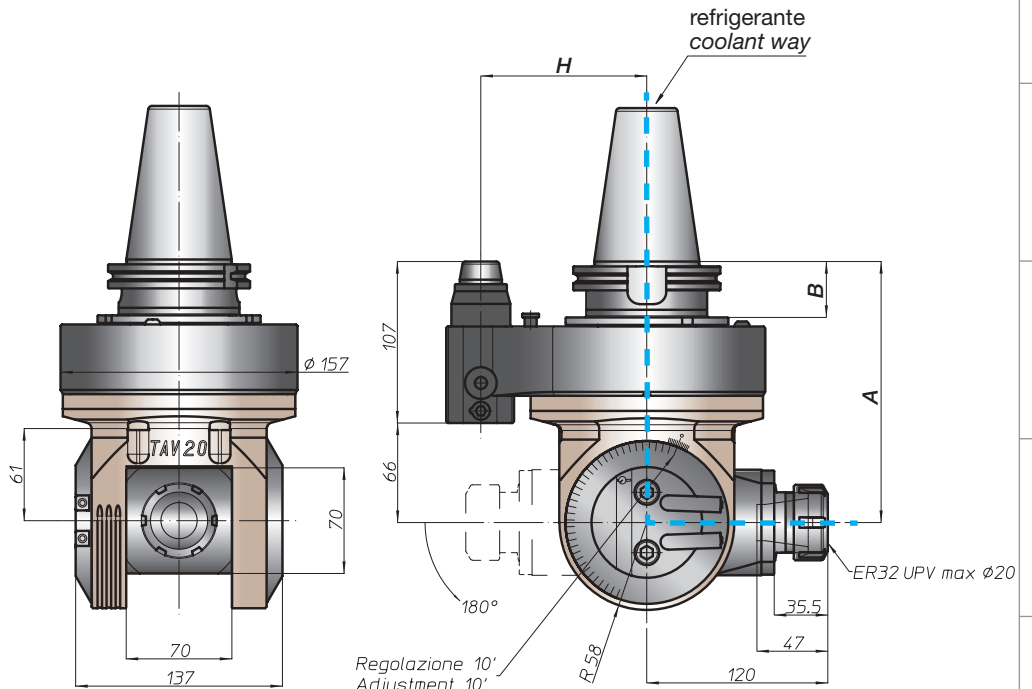

\* Option: Dual Contact



FH  
BAH  
TA.CP  
TA  
MO  
HT  
VH  
TSI/TSX  
T  
MT-TC-TC3  
Accessori  
Accessories  
Appendice tecnica  
Technical supplement

testa ad angolo - angle head

# TAV30.P



caratteristiche/features



  
 ø 30    M24    2740 N  

  
 1-1    2500

peso/weight



42 kg

rotazione/rotation



input



output

prestazioni/performance

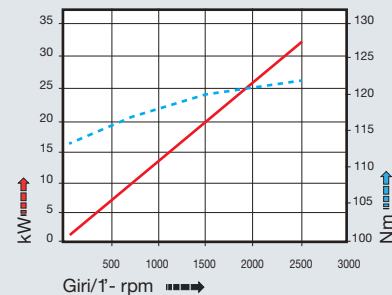

tipi mandrino disponibili / available spindle types

- 1** DIN6388-ER  
**ER50**
- 2** Albero portafresa  
Milling shaft  
**Ø32-Ø40**
- 4** DIN69893-HSK  
**HSK63**
- 6** ABS  
Licenza KOMET®  
**ABS63**

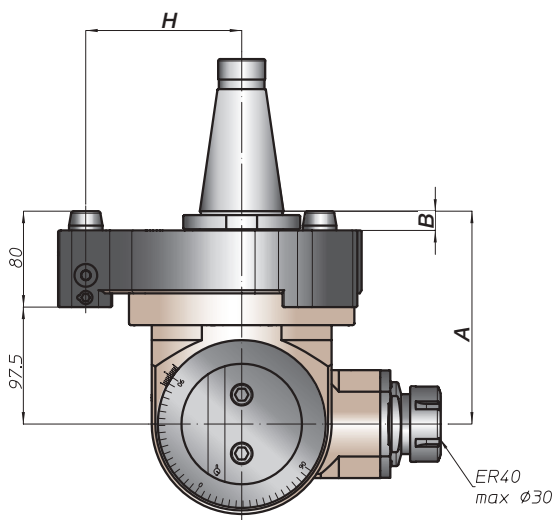
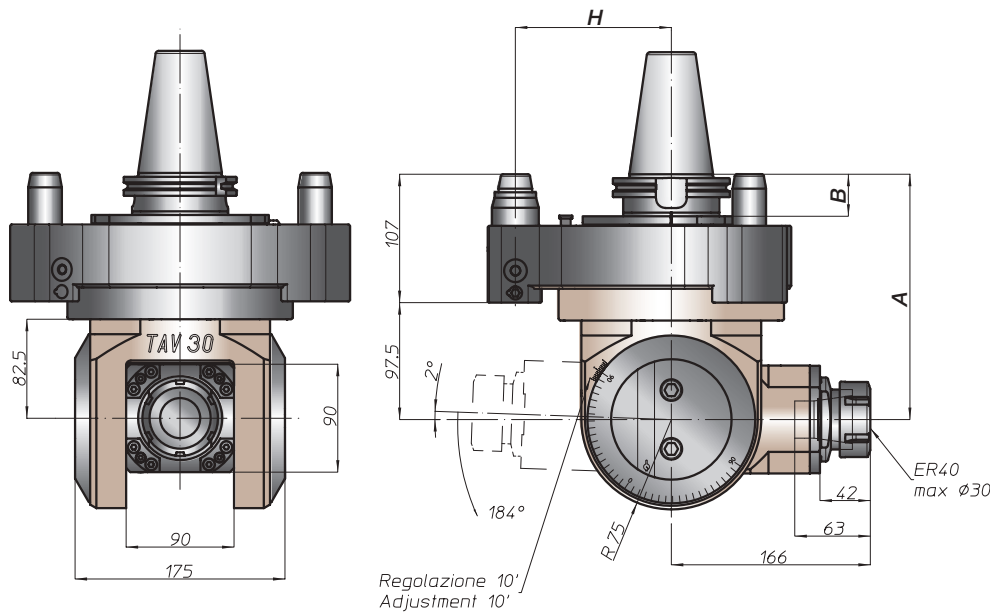

CONO SHANK	size	H			
		A	B	standard	optional
DIN69871 *	-	-	-	-	-
	50	204,5	35	130	-
ANSIB5.50 *	50	-	-	130	-
BT *	50	212,5	45	130	-
HSK	-	-	42	-	-
DIN69893	-	213,5	-	130	-
	100	-	46	130	-
CAPTO	-	-	-	-	-
ISO26623	-	208,5	-	130	-
	C8	-	-	-	-
KM	-	-	-	-	-
	100	204,5	-	130	-
DIN2080	-	-	-	-	-
	50	177,5	16	130	-
NMTB	-	-	-	-	-
ANSIB5.18	50	177,5	16	130	-

\* Option: Dual Contact



# TAV40.T



caratteristiche/features

peso/weight

prestazioni/performances



ø 32 M26 2610 N



70 kg

rotazione/rotation



1-2 5000 OUTPUT



input



output

Output data

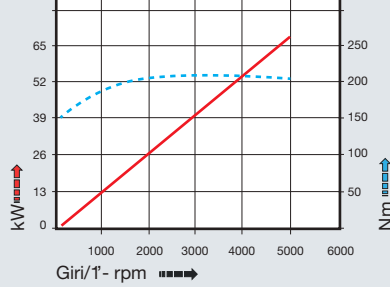

tipi mandrino disponibili / available spindle types

**4** DIN69893-HSK  
**HSK63**

**5** COROMANT CAPTO®  
**C5**

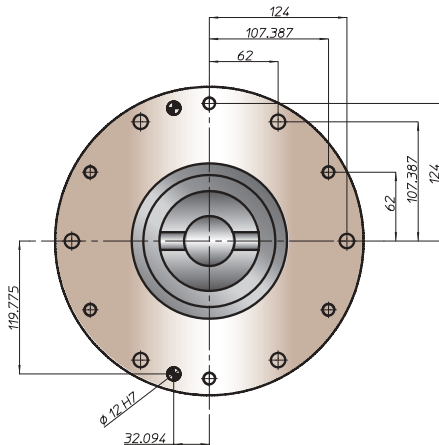
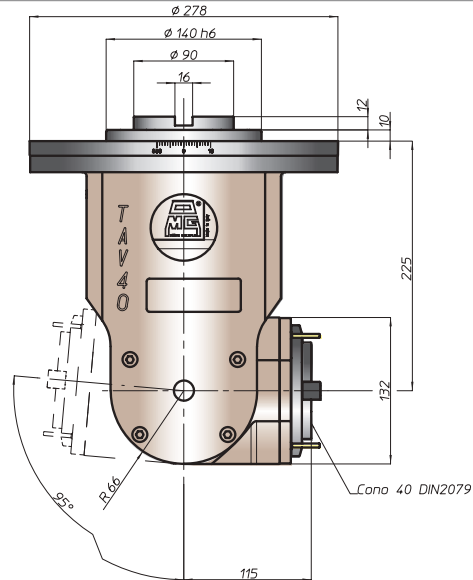
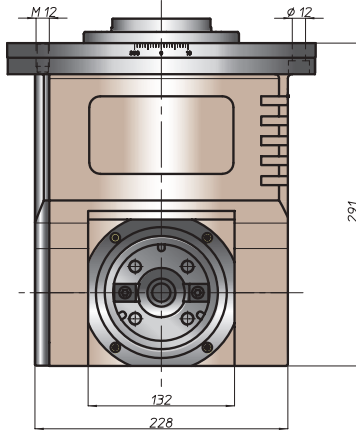

**Equipaggiamento standard:**

- pressurizzazione mandrino
- n. 4 ugelli orientabili vicino al mandrino
- regolazione angolare mandrino libera
- nel mandrino DIN2079 si possono utilizzare coni DIN2080-40, DIN69871-A40, MAS403-BT40

**Standard equipment:**

- spindle front pressurization
- nr 4 adjustable nozzle near the spindle
- free angle spindle adjustment
- on the spindle DIN2079 you can use shank DIN2080-40, DIN69871-A40, MAS403-BT40

esempio di collegamento - connection example

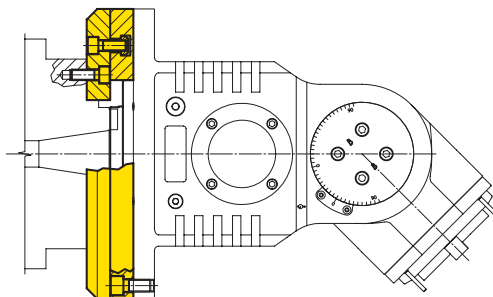

FH  
BAH  
TA.CP  
TA  
MO  
HT  
VH  
TSI/TSX  
T  
MT-TC-TC3  
Accessori  
Accessories  
Appendice tecnica  
Technical supplement

# TAV50.T



caratteristiche/features



  
 $\varnothing 45$     M36    6180 N



  
 1-2    4000 OUTPUT

peso/weight



145 kg

rotazione/rotation



input



output

prestazioni/performance

Output data

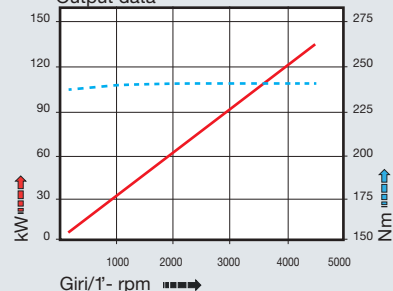

tipi mandrino disponibili / available spindle types

4 DIN69893-HSK    5 COROMANT CAPTO®

**A100**                      **C8**

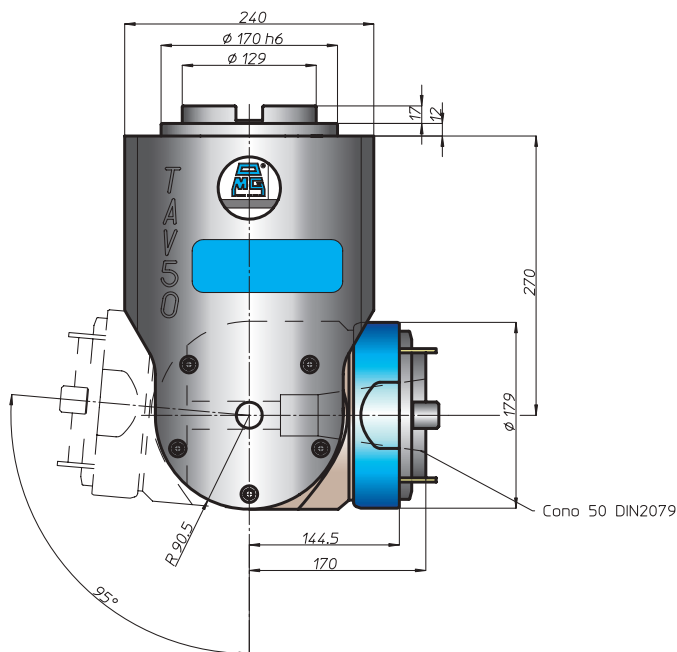
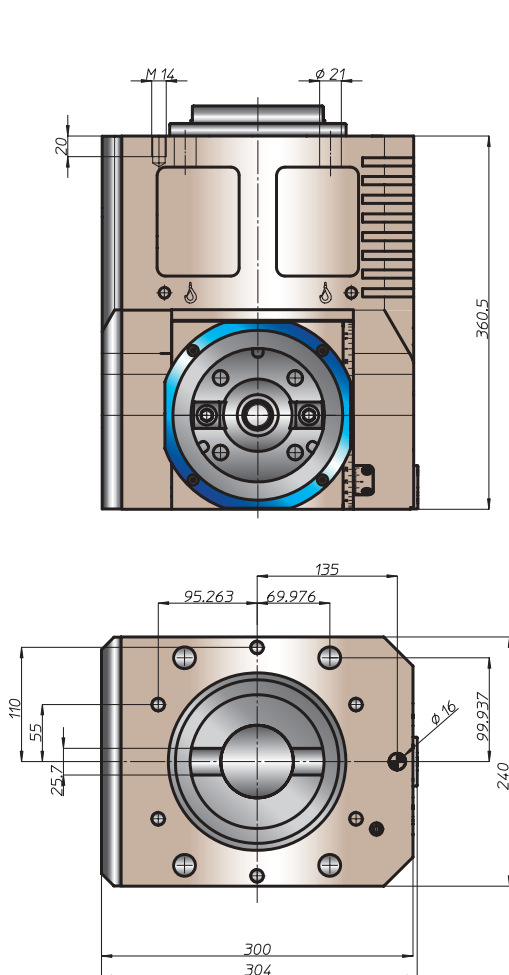

**Equipaggiamento standard:**

- pressurizzazione mandrino
- n. 4 ugelli orientabili vicino al mandrino
- regolazione angolare mandrino libera o posizionabile ogni 15°
- nel mandrino DIN2079 si possono utilizzare coni DIN69871-A50, MAS403-BT50

**Standard equipment:**

- spindle front pressurization
- nr 4 adjustable nozzle near the spindle
- free angle spindle adjustment or by pin each 15°
- on the spindle DIN2079 you can use shank DIN69871-A50, MAS403-BT50

**esempio di collegamento - connection example**

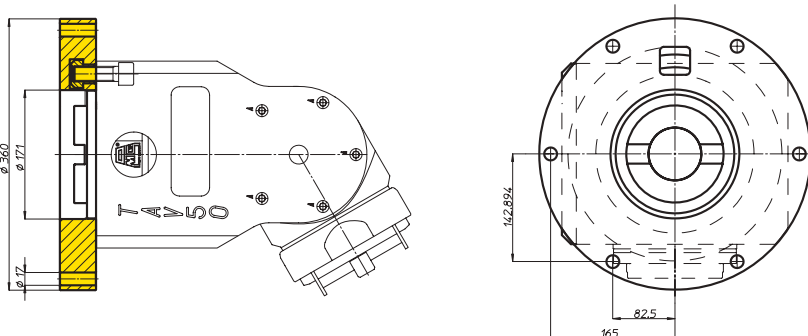

# TAV Gallery



FH

BAH

TA.CP

TA

MO

HT

VH

TSI/TSX

T

MT-TC-TC3

Accessori  
Accessories

Appendice tecnica  
Technical supplement



# TAF Gallery



FH

BAH

TA-CP

TA

MO

HT

VH

TSI/TSX

T

MT-TC-TC3

Accessori  
Accessories

Appendice tecnica  
Technical supplement



# TAF10.P



caratteristiche/features

ø 10    M8    510 N  
 1-1    5000

peso/weight

40    50  
 5,5 kg    7 kg

rotazione/rotation

IN    OUT  
 input    output

prestazioni/performance

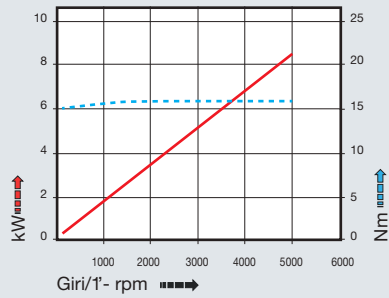

CONO SHANK	size	A	B	H	
				standard	optional
* DING9871	30	132	35	65	-
	40			80	110
	45			80	110
	50			80	110
* ANSIB5.50 CAT	40	132	35	65	-
	50			80	110
* BT	40	140	45	65	-
	50			80	110
DING9893 HSK	63	141	42	65	-
	80			80	110
	100			80	110
ISO26623 CAPTO	C5	136	39	65	-
	C6			80	110
	C8			80	110
KM	63	132	35	65	-
	80			80	110
	100			80	110
DIN2080	-	132	35	-	-
	-			-	-
	-			-	-
ANSIB5.18 NMTB	-	132	35	-	-
	-			-	-

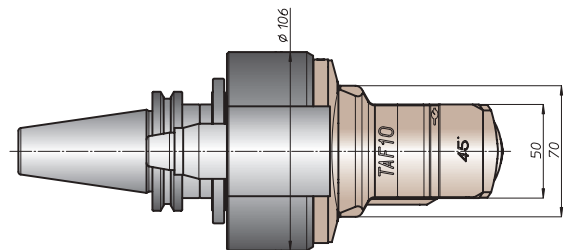
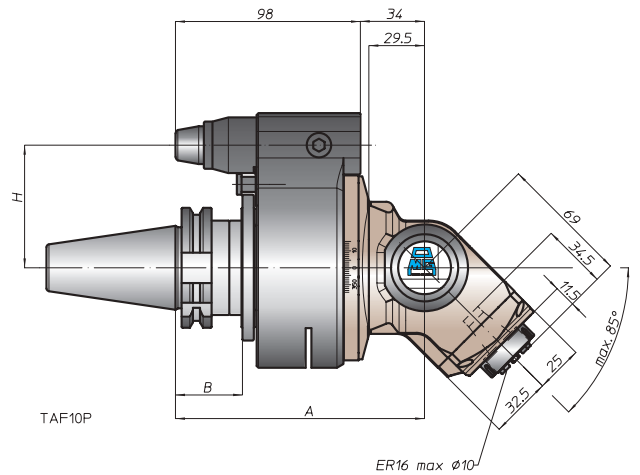
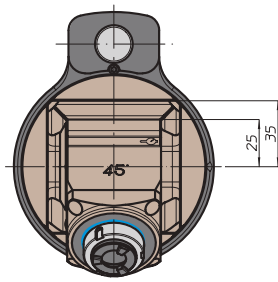

\* Option: Dual Contact



FH  
 BAH  
 TA.CP  
 TA  
 MO  
 HT  
 VH  
 TSI/TSX  
 T  
 MT-TC-TC3  
 Accessori  
 Accessories  
 Appendice tecnica  
 Technical supplement

testa ad angolo - angle head

# TAF13.P



caratteristiche/features



peso/weight

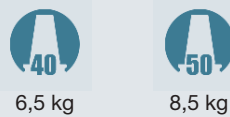

rotazione/rotation



prestazioni/performance

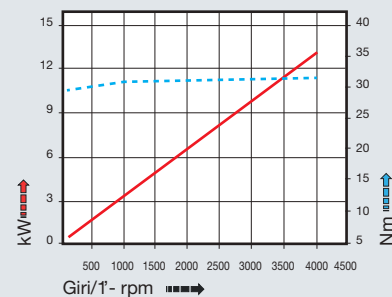

tipi mandrino disponibili / available spindle types

**4** DIN69893-HSK  
**HSK32**

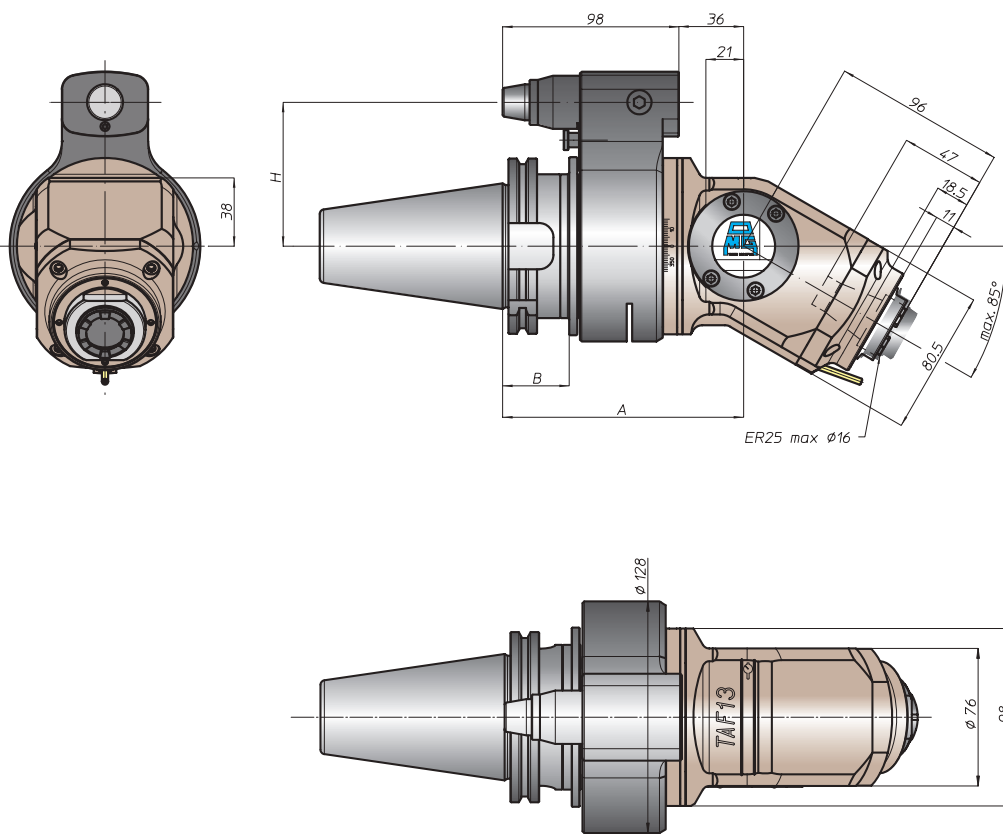

CONO SHANK	size	H			
		A	B	standard	optional
* DIN69871	-			65	-
	40	134	35	80	110
	45			80	110
50	80			110	
* ANSIB5.50	40			65	-
	50			80	110
* BT	40			65	
	50	142	45	80	110
HSK	63		42	65	
	80	143		80	110
	100		46	80	110
CAPTO	C5			65	
	C6	138	39		
	C8			80	110
KM	63			65	
	80	134		80	110
	100			80	110
DIN2080	-			-	-
	-			-	-
	-			-	-
ANSIB5.18	-			-	-
	-			-	-

\* Option: Dual Contact

FH  
BAH  
TA-CP  
TA  
MO  
HT  
VH  
TSI/TSX  
T  
MT-TC-TC3  
Accessori  
Accessories  
Appendice tecnica  
Technical supplement







testa ad angolo - angle head

# TAF20.P



caratteristiche/features



  
 ø 20    M16    1610 N  

  
 1-1    3000

peso/weight



13,5 kg

rotazione/rotation



input



output

prestazioni/performance

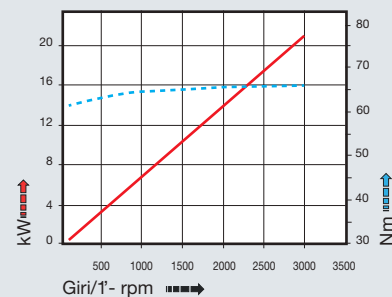

tipi mandrino disponibili / available spindle types

- 1** DIN6388-ER  
ER40
- 2** Albero portafresa  
Milling shaft  
Ø32
- 3** Weldon  
Whistle-Notch  
Ø20
- 4** DIN69893-HSK  
HSK50
- 6** ABS  
Licenza KOMET®  
ABS50

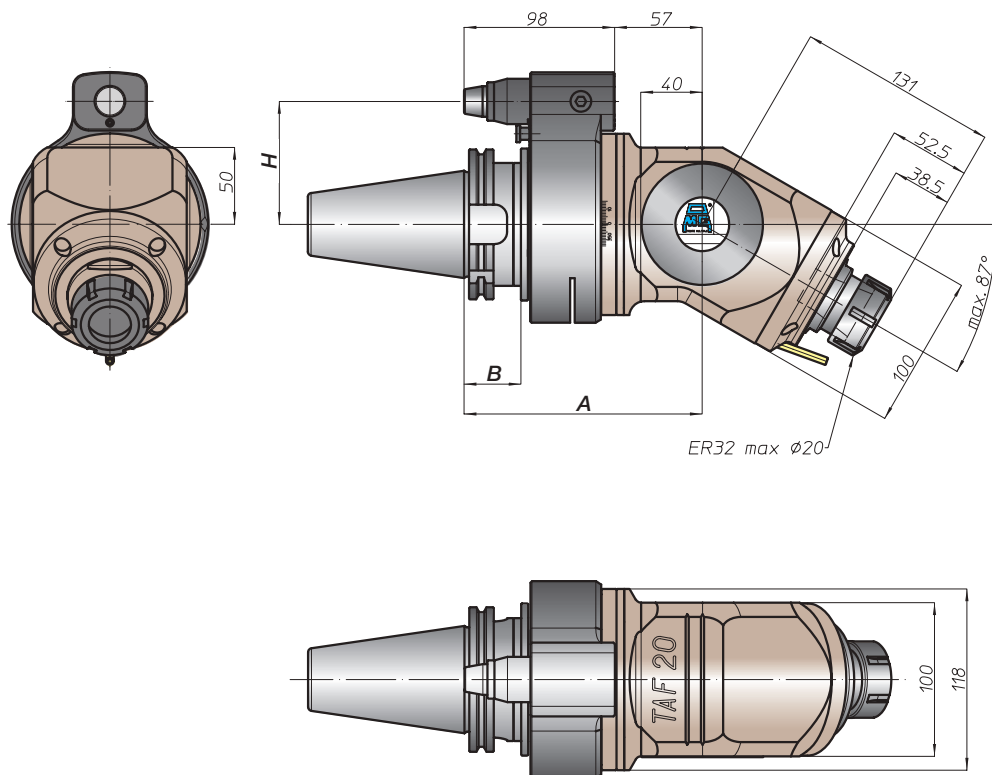

CONO SHANK	size	H			
		A	B	standard	optional
DIN69871 *	-	-	-	-	-
DIN69871 *	45	-	-	80	110
DIN69871 *	50	155	35	80	110
ANSIB5.50 *	-	-	-	-	-
ANSIB5.50 *	50	-	-	80	110
BT *	-	-	-	-	-
BT *	50	163	45	80	110
HSK	-	-	42	-	-
DIN69893	80	164	-	80	110
DIN69893	100	-	46	80	110
CAPTO	-	-	-	-	-
ISO26623	C6	159	-	80	110
ISO26623	C8	-	-	-	-
KM	-	-	-	-	-
KM	80	155	-	80	110
KM	100	-	-	-	-
DIN2080	-	-	-	-	-
DIN2080	-	-	-	-	-
DIN2080	-	-	-	-	-
NMTB	-	-	-	-	-
ANSIB5.18	-	-	-	-	-
ANSIB5.18	-	-	-	-	-

\* Option: Dual Contact



# TAF20.PD

caratteristiche/features

$\varnothing$  20    M16    1610 N  
 1-1    3000    70 bar

peso/weight



13,5 kg

rotazione/rotation



input



output

prestazioni/performance

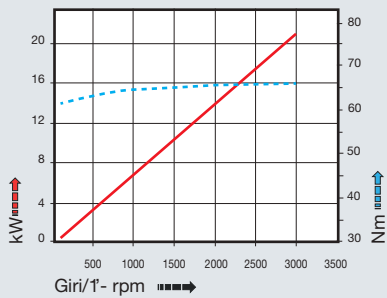

CONO SHANK	size	A	B	H	
				standard	optional
 DIN69871 *	-	155	35	-	-
	45			80	110
	50			80	110
 ANSIB5.50 * CAT	-	155	35	-	-
	50			80	110
 * BT	-	163	45	80	110
	50			80	110
 HSK	-	164	42	-	-
	80		80	110	
	100		80	110	
 CAPTO	-	159	-	-	-
	C6		80	110	
 KM	-	155	-	-	-
	80		80	110	
 DIN2080	-	155	-	-	-
	80		80	110	
 NMTB	-	155	-	-	-
	80		80	110	

tipi mandrino disponibili / available spindle types

- 1 DIN6388-ER  
ER40
- 3 Weldon Whistle-Notch  
Ø20
- 4 DIN69893-HSK  
HSK50
- 6 ABS Licenza KOMET®  
ABS50

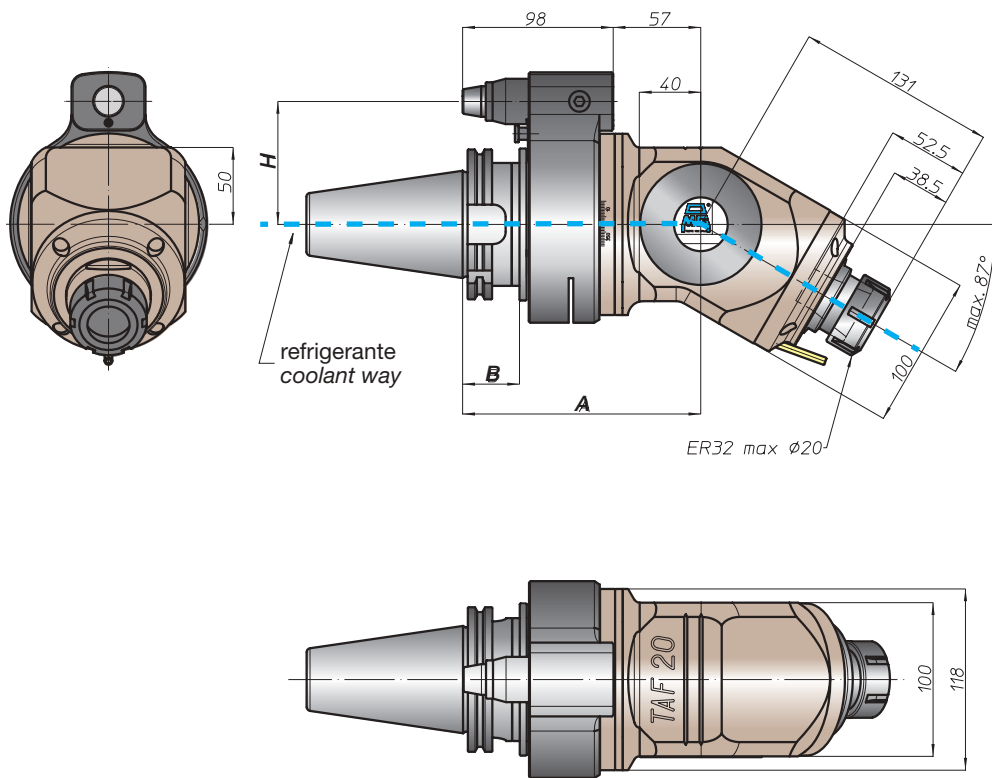

\* Option: Dual Contact



FH  
BAH  
TA.CP  
TA  
MO  
HT  
VH  
TSI/TSX  
T  
MT-TC-TC3  
Accessori  
Accessories  
Appendice tecnica  
Technical supplement

# TA07P.T



caratteristiche/features

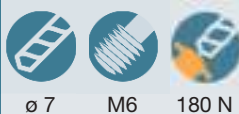

ø 7 M6 180 N



1-1 10000

peso/weight



1,5 kg



L 100=2,2 kg  
L 200=3,6 kg

rotazione/rotation



input



output

prestazioni/performance

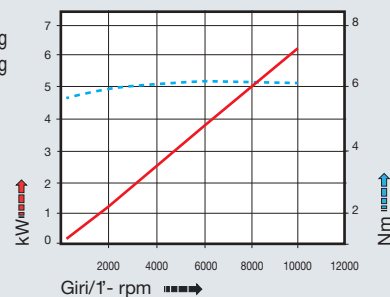

tipi mandrino disponibili / available spindle types

**3** Weldon Whistle-Notch  
Ø8-Ø10

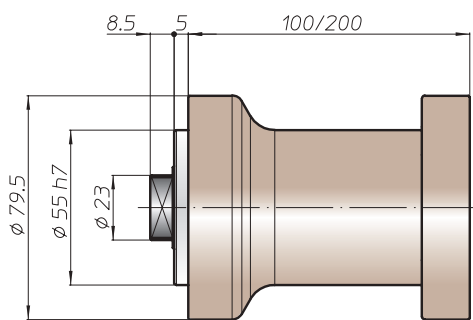
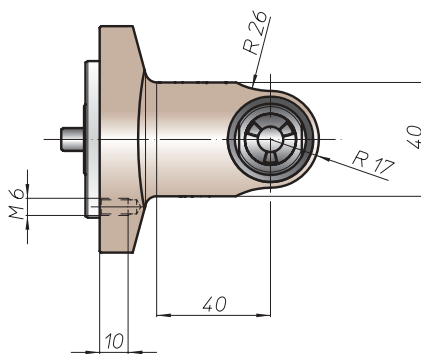

Prolunga  
Extension

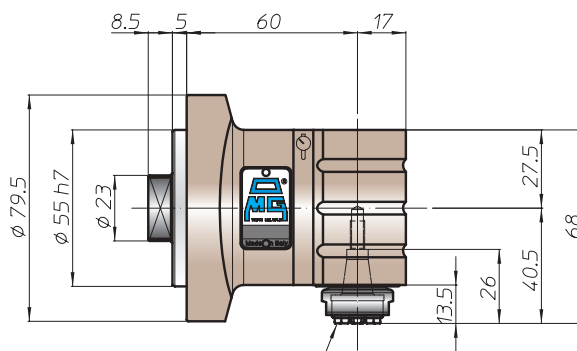

ER11 max ø 7

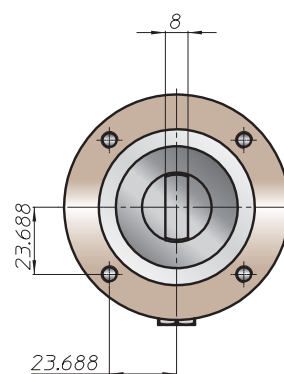

esempio di collegamento - connection example

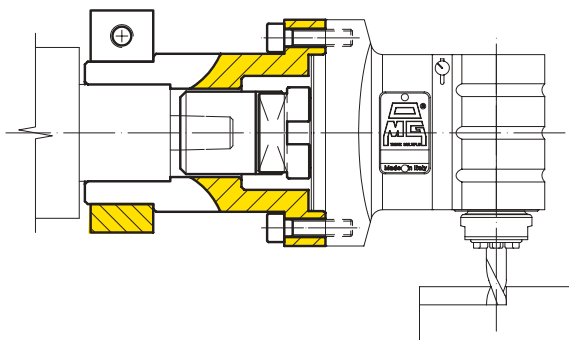

# TA10P.T

caratteristiche/features



peso/weight



rotazione/rotation



prestazioni/performance

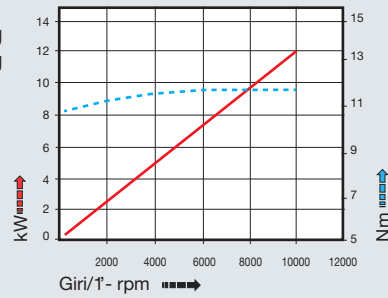

tipi mandrino disponibili / available spindle types

- |                     |   |                                  |
|---------------------|---|----------------------------------|
| <b>1</b> DIN6388-ER | <b>2</b> Albero portafrese<br>Milling shaft | <b>3</b> Weldon<br>Whistle-Notch |
| <b>ER20</b>         | <b>Ø16</b>                                  | <b>Ø10</b>                       |

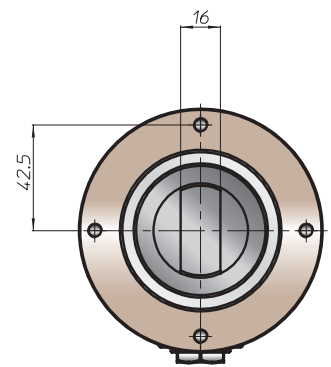
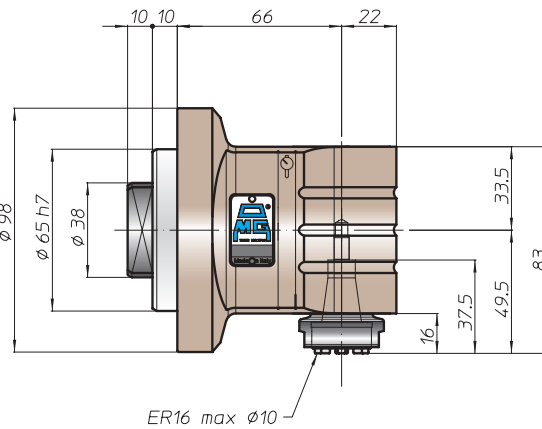
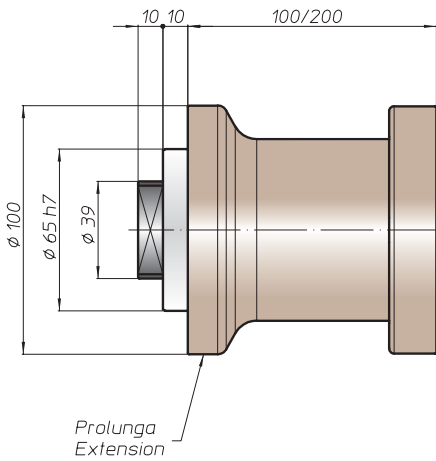
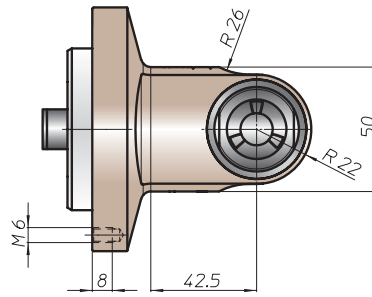

esempio di collegamento - connection example

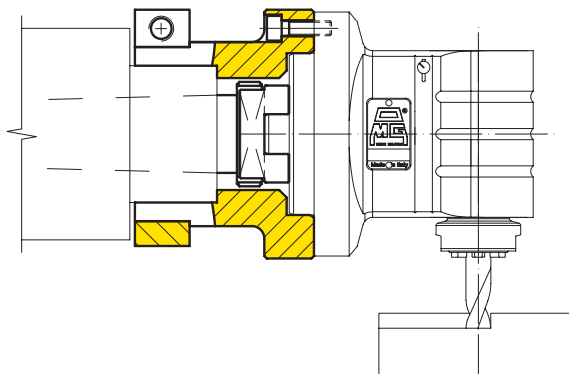

FH  
BAH  
TA.CP  
TA  
MO  
HT  
VH  
TSI/TSX  
T  
MT-TC-TC3  
Accessori  
Accessories  
Appendice tecnica  
Technical supplement



testa ad angolo - angle head

# TA13P.T



caratteristiche/features



peso/weight



3,5 kg

rotazione/rotation



input



output

prestazioni/performance

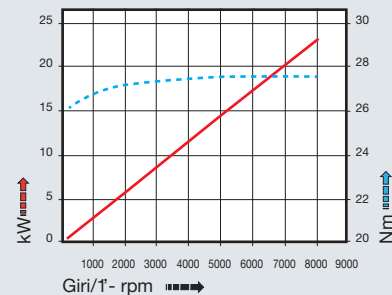

tipi mandrino disponibili / available spindle types

- 1** DIN6388-ER  
ER25
- 2** Albero portafresa  
Milling shaft  
Ø16-Ø22
- 3** Weldon  
Whistle-Notch  
Ø16

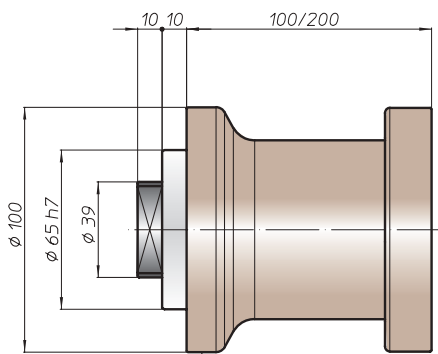
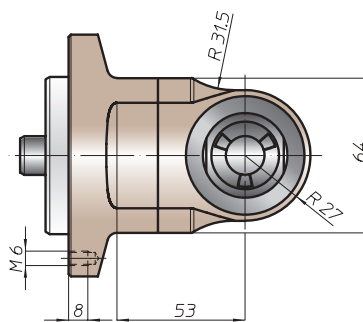

Prolunga  
Extension

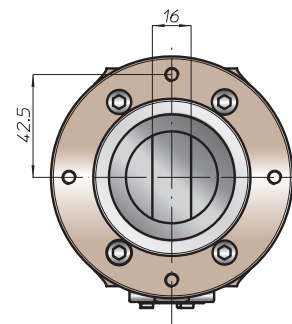
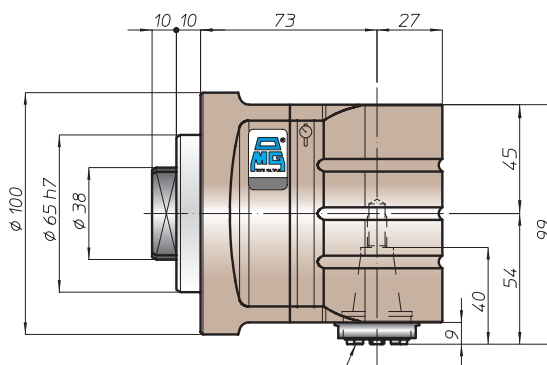

esempio di collegamento - connection example

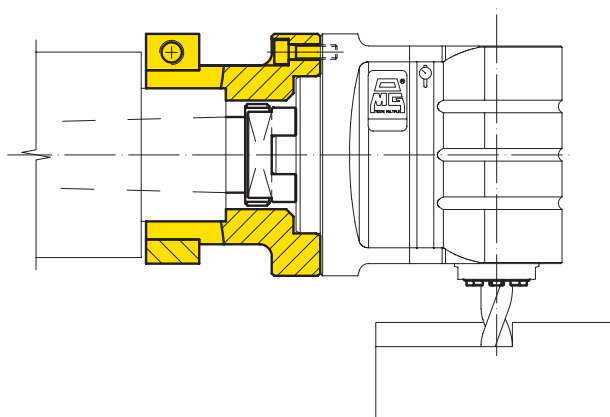

FH  
BAH  
TA-CP  
TA  
MO  
HT  
VH  
TSI/TSX  
T  
MT-TC-TC3  
Accessori  
Accessories  
Appendice tecnica  
Technical supplement





testa ad angolo - angle head

# TA20.PT



caratteristiche/features



peso/weight



rotazione/rotation



prestazioni/performance

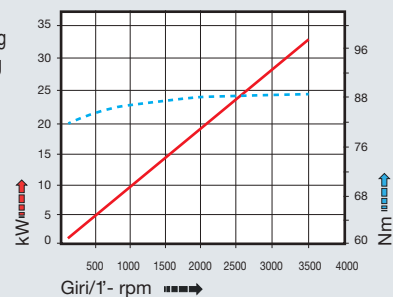

tipi mandrino disponibili / available spindle types

- |                                    |   |  |                                       |  |  |
|------------------------------------|---|--|---------------------------------------|--|--|
| <b>1</b> DIN6388-ER<br><b>ER40</b> | <b>2</b> Albero portafrese<br>Milling shaft<br><b>Ø22-Ø27-Ø32</b> | <b>3</b> Weldon<br>Whistle-Notch<br><b>Ø20-Ø25</b> | <b>4</b> DIN69893-HSK<br><b>HSK40</b> | <b>5</b> COROMANT<br>CAPTO®<br><b>C4</b> | <b>6</b> ABS<br>Licenza KOMET®<br><b>ABS40</b> |
|------------------------------------|---|--|---------------------------------------|--|--|

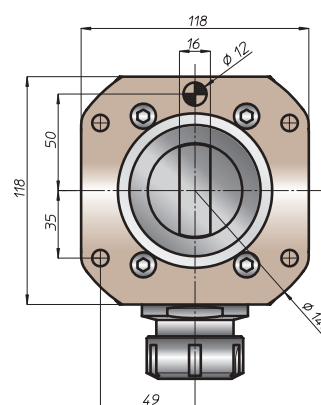
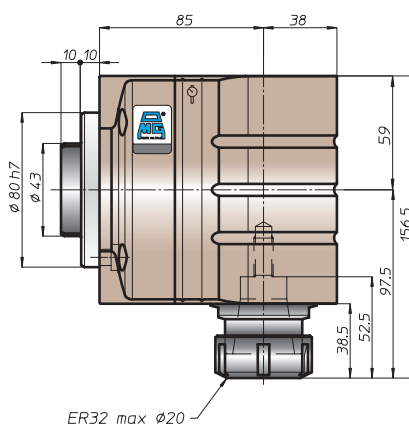
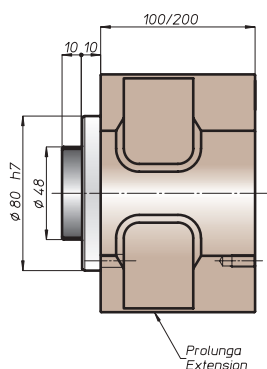
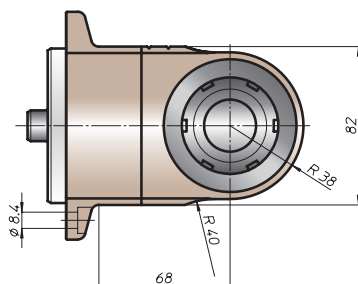

esempio di collegamento - connection example

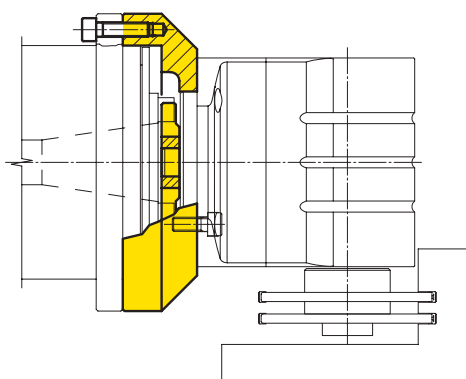

FH  
BAH  
TA.CP  
TA  
MO  
HT  
VH  
TSI/TSX  
T  
MT-TC-TC3  
Accessori  
Accessories  
Appendice tecnica  
Technical supplement







testa ad angolo - angle head

# TA26.PT



### caratteristiche/features



### peso/weight



### rotazione/rotation



### prestazioni/performance

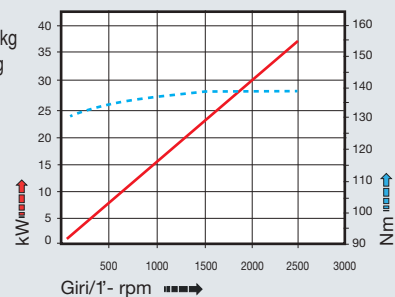

### tipi mandrino disponibili / available spindle types

- |   |  |                                |                                   |   |
|---|--|--------------------------------|-----------------------------------|---|
| <b>2</b> Albero portafresa<br>Milling shaft<br>$\varnothing 16$ - $\varnothing 27$ - $\varnothing 32$ | <b>3</b> Weldon<br>Whistle-Notch<br>$\varnothing 32$ | <b>4</b> DIN69893-HSK<br>HSK63 | <b>5</b> COROMANT<br>CAPTO®<br>C4 | <b>6</b> ABS<br>Licenza KOMET®<br>ABS50 |
|---|--|--------------------------------|-----------------------------------|---|

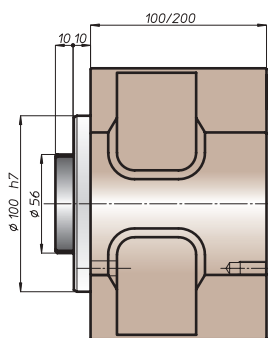
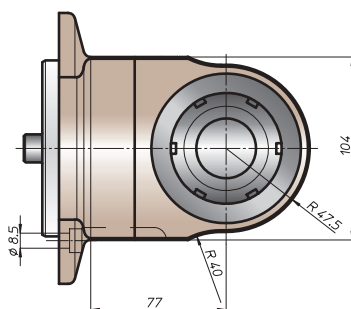

Prolunga  
Extension

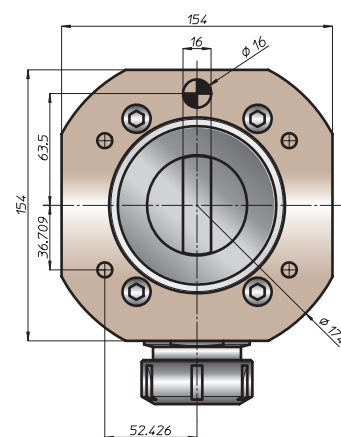
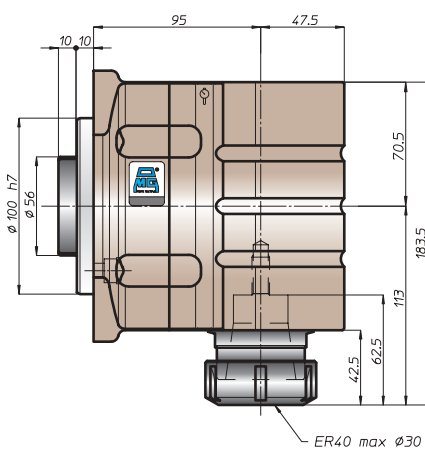

### esempio di collegamento - connection example



FH  
BAH  
TA.CP  
TA  
MO  
HT  
VH  
TSI/TSX  
T  
MT-TC-TC3  
Accessori  
Accessories  
Appendice tecnica  
Technical supplement



# TA26.40.T

caratteristiche/features



peso/weight



rotazione/rotation



prestazioni/performance

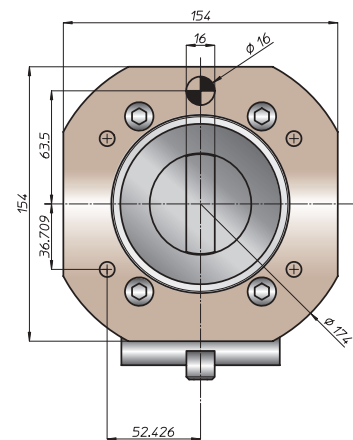
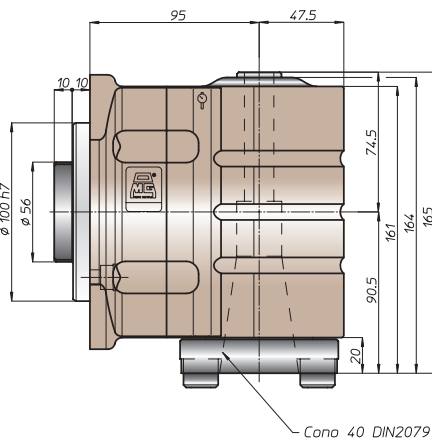
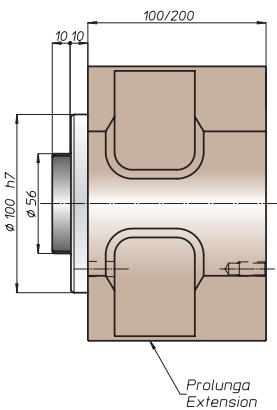
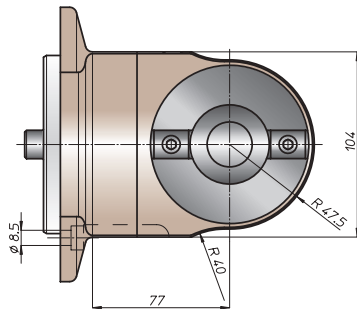
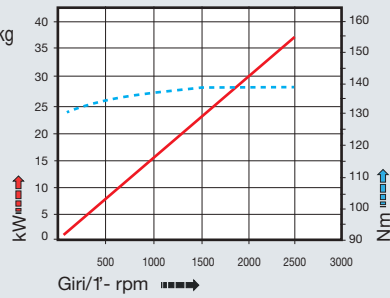

**Nota:**

- nel mandrino DIN2079 si possono utilizzare coni DIN2080-40, DIN69871-A40, MAS403-BT40

**Note:**

- on the spindle DIN2079 you can use shank DIN2080-40, DIN69871-A40, MAS403-BT40

## esempio di collegamento - connection example



FH

BAH

TA.CP

TA

MO

HT

VH

TSI/TSX

T

MT-TC-TC3

Accessori  
Accessories

Appendice tecnica  
Technical supplement



testa ad angolo - angle head

# TA40.T



caratteristiche/features



peso/weight



rotazione/rotation



prestazioni/performance

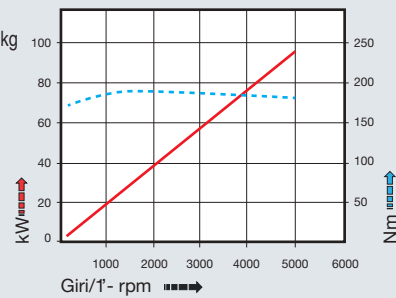

tipi mandrino disponibili / available spindle types

- 4 DIN69893-HSK  
**HSK63**
- 5 COROMANT CAPTO®  
**C5**

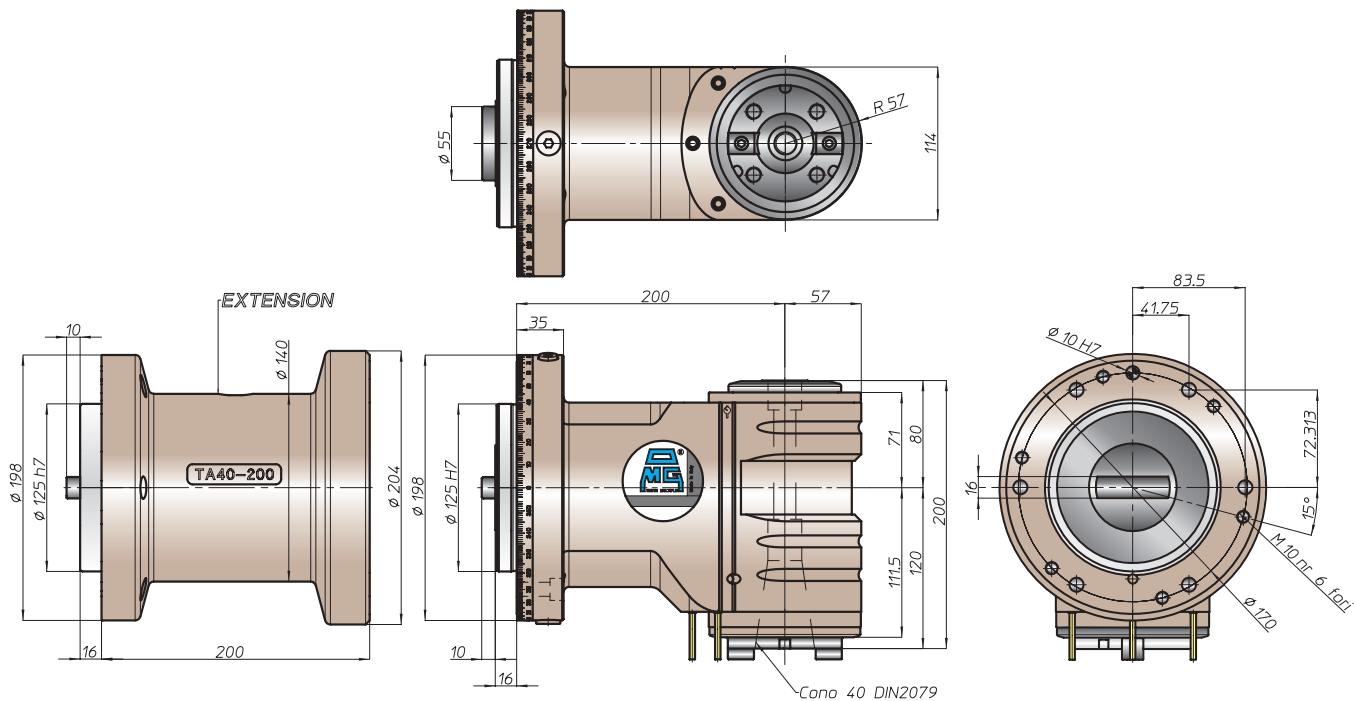

**Equipaggiamento standard:**

- pressurizzazione mandrino
- n. 3 ugelli orientabili vicino al mandrino
- nel mandrino DIN2079 si possono utilizzare coni DIN2080-40, DIN69871-A40, MAS403-BT40

**Standard equipment:**

- spindle front pressurization
- nr 3 adjustable nozzle near the spindle
- on the spindle DIN2079 you can use shank DIN2080-40, DIN69871-A40, MAS403-BT40

applicazione con asse C-310 manuale - example with manual C axis C-310

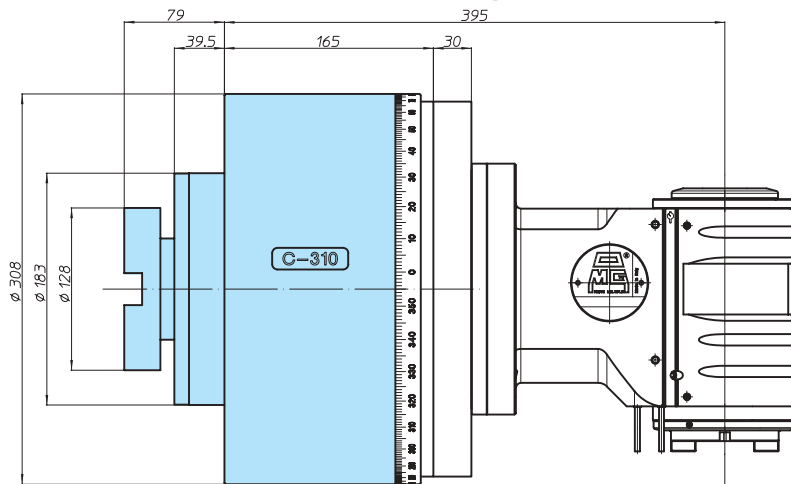



testa ad angolo - angle head

# TA50.T



caratteristiche/features

$\phi$  45    M36    5800 N

1-1    4000

peso/weight

head **108 kg**
  
 extension **110 kg** (L 300)

rotazione/rotation

IN OUT

prestazioni/performance

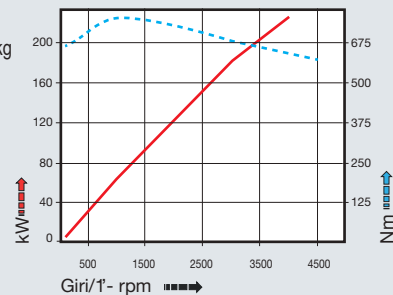

tipi mandrino disponibili / available spindle types

- 4** DIN69893-HSK    **5** COROMANT CAPTO®
- HSK100**                      **C8**

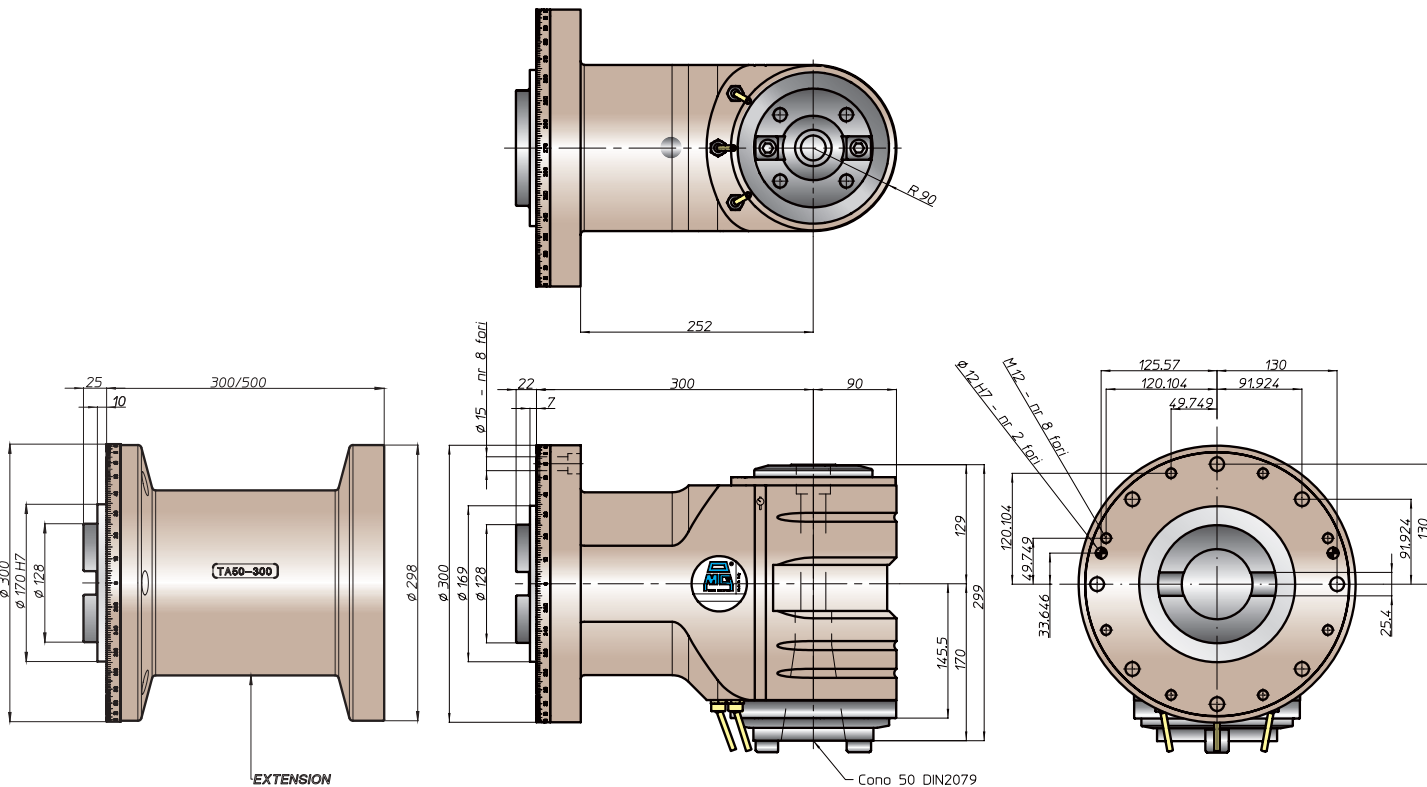

Equipaggiamento standard:

- pressurizzazione mandrino
- n. 3 ugelli orientabili vicino al mandrino
- nel mandrino DIN2079 si possono utilizzare coni DIN2080-50, DIN69871-A50, MAS403-BT50

Standard equipment:

- spindle front pressurization
- nr 3 adjustable nozzle near the spindle
- on the spindle DIN2079 you can use shank DIN2080-50, DIN69871-A50, MAS403-BT50

applicazione con asse C-310 manuale - example with manual C axis C-310

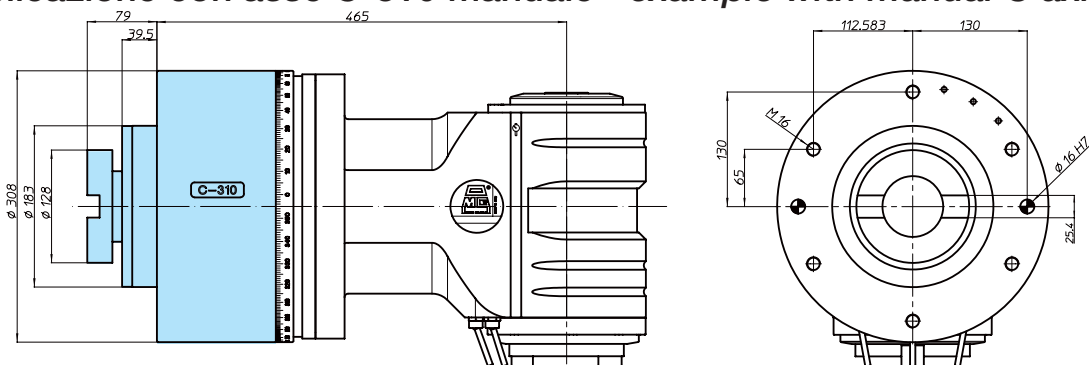

# TA50.TD



caratteristiche/features

$\varnothing$  45    M36    5800 N  
 1-1    4000    50 bar

peso/weight

head 112 kg  
 extension L 300=110 kg

rotazione/rotation

IN OUT  
 input                      output

prestazioni/performance

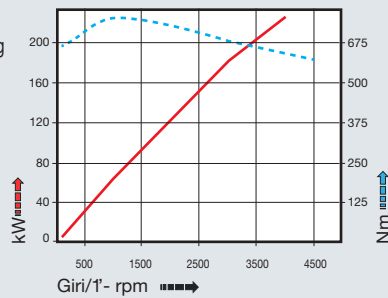

tipi mandrino disponibili / available spindle types

4 DIN69893-HSK    5 COROMANT CAPTO®  
**HSK100**                      **C8**

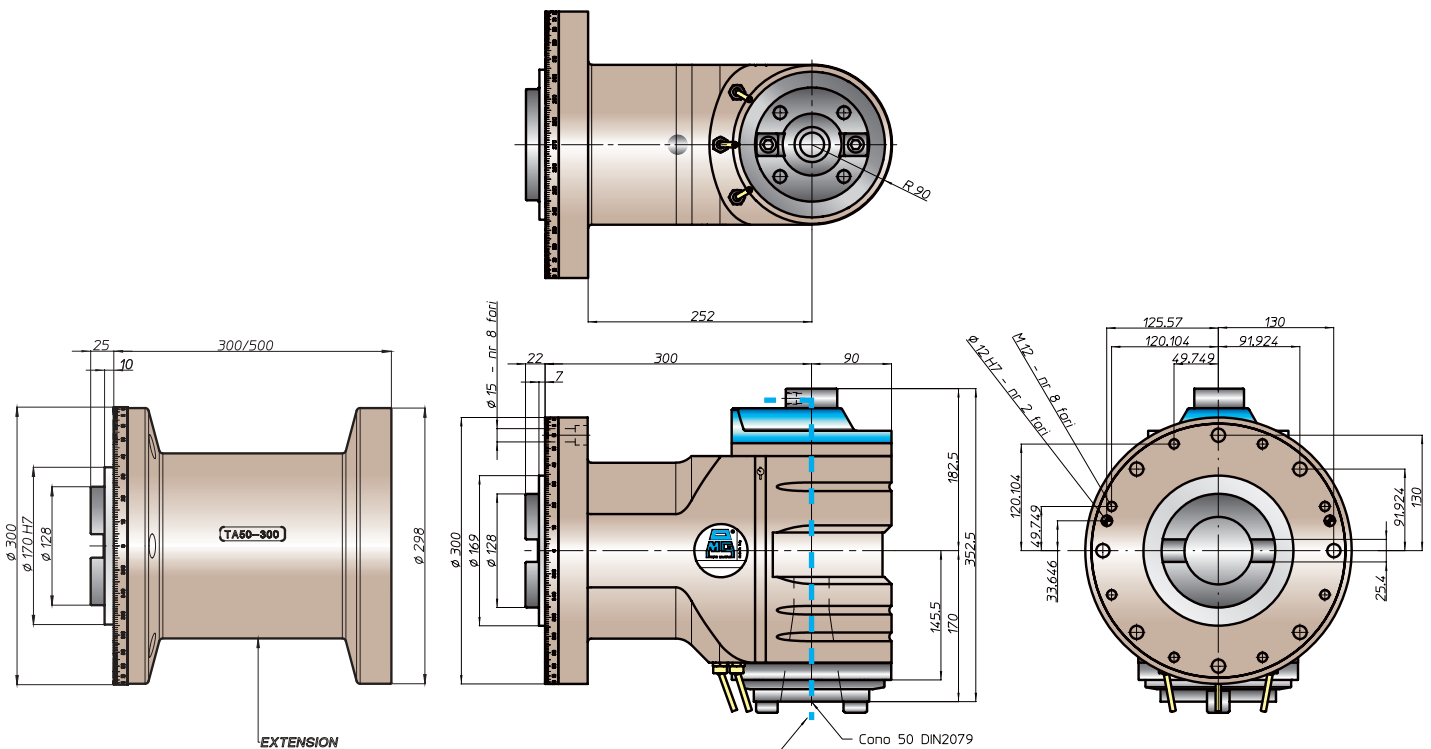

**Equipaggiamento standard:**

- pressurizzazione mandrino
- n. 3 ugelli orientabili vicino al mandrino
- nel mandrino DIN2079 si possono utilizzare coni DIN69871-A50, MAS403-BT50

**Standard equipment:**

- spindle front pressurization
- nr 3 adjustable nozzle near the spindle
- on the spindle DIN2079 you can use shank DIN69871-A50, MAS403-BT50

esempio di collegamento rotante - rotating connection example

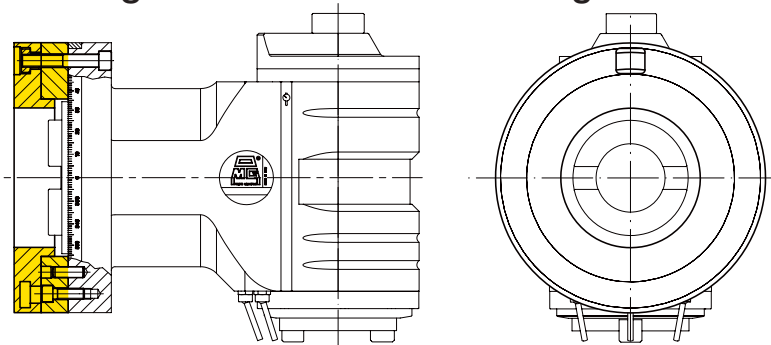

FH  
 BAH  
 TA.CP  
 TA  
 MO  
 HT  
 VH  
 TSI/TSX  
 T  
 MT-TC-TC3  
 Accessori  
 Accessories  
 Appendice tecnica  
 Technical supplement

# TA..T Extended Gallery



FH

BAH

TA.CP

TA

MO

HT

VH

TSI/TSX

T

MT-TC-TC3

Accessori  
Accessories

Appendice tecnica  
Technical supplement





# TA..T Extended Gallery



FH

BAH

TA.CP

TA

MO

HT

VH

TSI/TSX

T

MT-TC-TC3

Accessori  
Accessories

Appendice tecnica  
Technical supplement



testa ad angolo - angle head

# TA13.PVDI



caratteristiche/features



peso/weight



4,5 kg

rotazione/rotation



input



output

prestazioni/performance

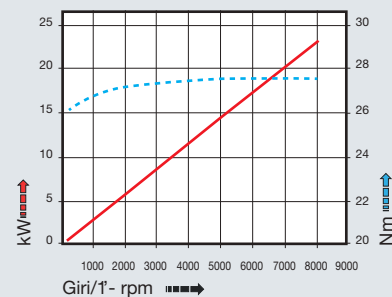

tipi mandrino disponibili / available spindle types

- 1** DIN6388-ER  
ER25
- 2** Albero portafrese  
Milling shaft  
Ø16-Ø22
- 3** Weldon  
Whistle-Notch  
Ø16

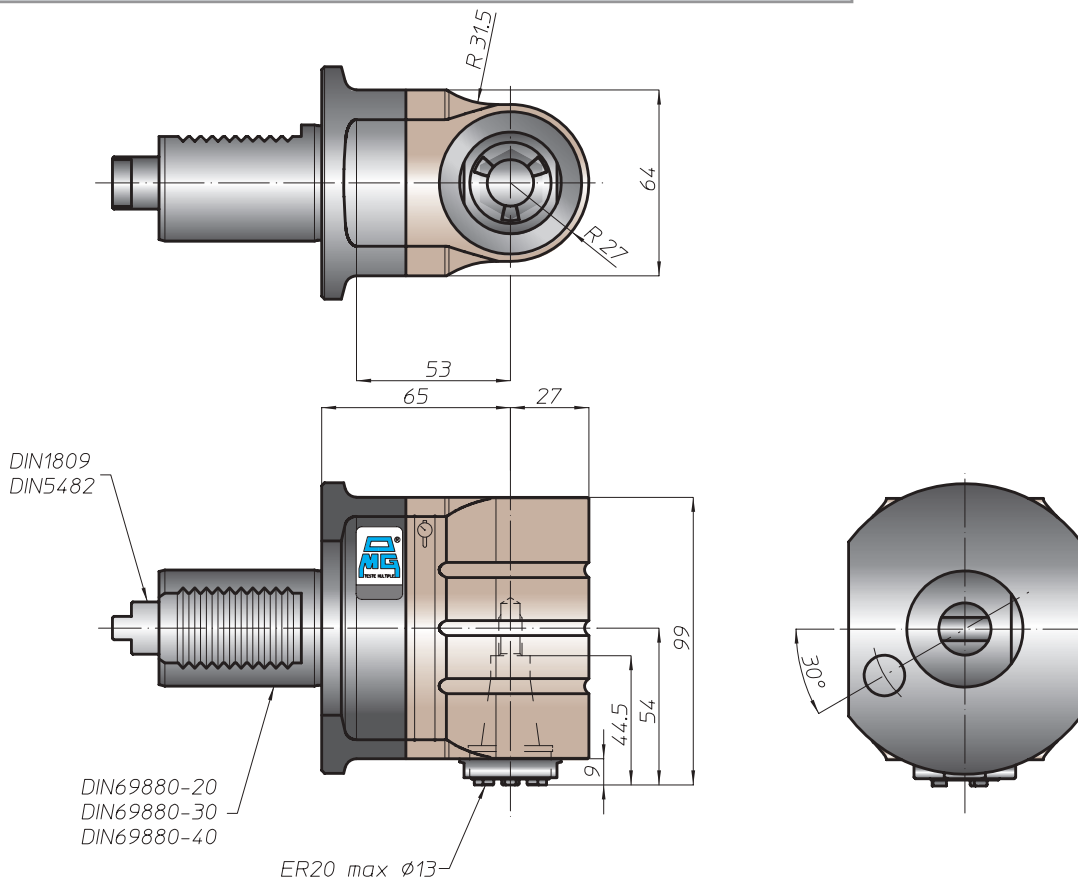

soluzioni speciali - special solutions

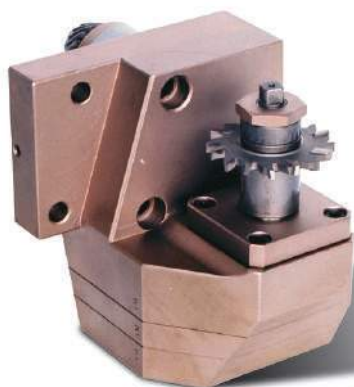

FH  
BAH  
TA-CP  
TA  
MO  
HT  
VH  
TSI/TSX  
T  
MT-TC-TC3  
Accessori  
Accessories  
Appendice tecnica  
Technical supplement



# TA16.PVDI

caratteristiche/features



peso/weight



rotazione/rotation



prestazioni/performance

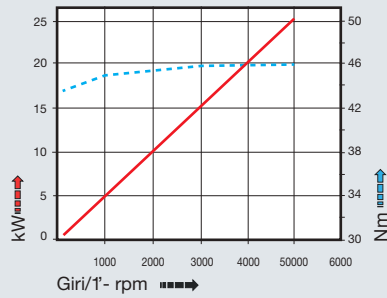

tipi mandrino disponibili / available spindle types

- |                                    |   |  |                                       |  |  |
|------------------------------------|---|--|---------------------------------------|--|--|
| <b>1</b> DIN6388-ER<br><b>ER32</b> | <b>2</b> Albero portafresa<br>Milling shaft<br><b>Ø16-Ø27-Ø32</b> | <b>3</b> Weldon<br>Whistle-Notch<br><b>Ø20</b> | <b>4</b> DIN69893-HSK<br><b>HSK32</b> | <b>5</b> COROMANT<br>CAPTO®<br><b>C3</b> | <b>6</b> ABS<br>Licenza KOMET®<br><b>ABS32</b> |
|------------------------------------|---|--|---------------------------------------|--|--|

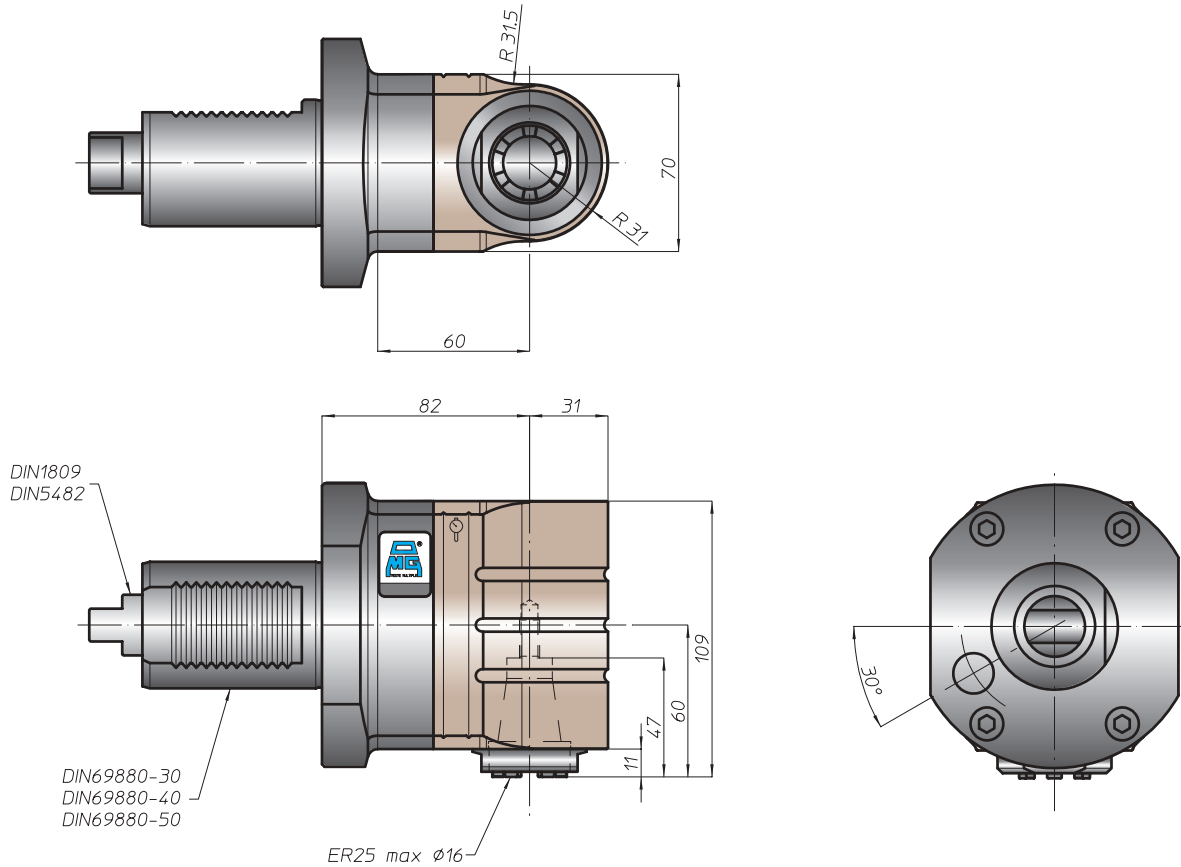

soluzioni speciali - special solutions

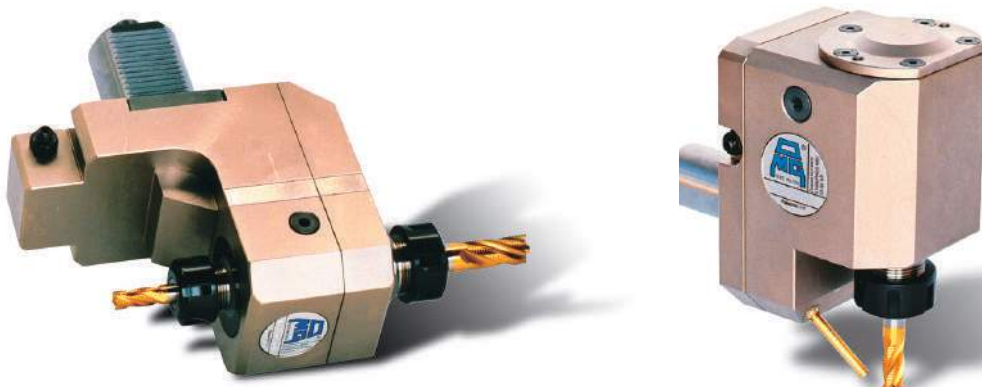

testa ad angolo - angle head

# TAV10.PVDI

caratteristiche/features



peso/weight



3,5 kg

rotazione/rotation



input



output

prestazioni/performance

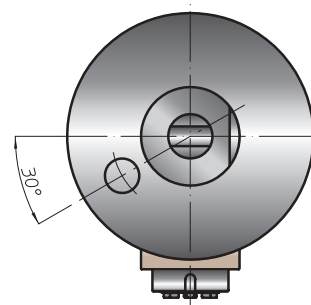
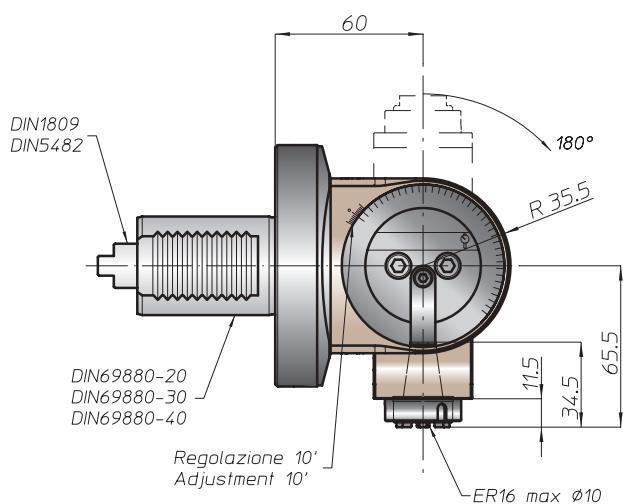
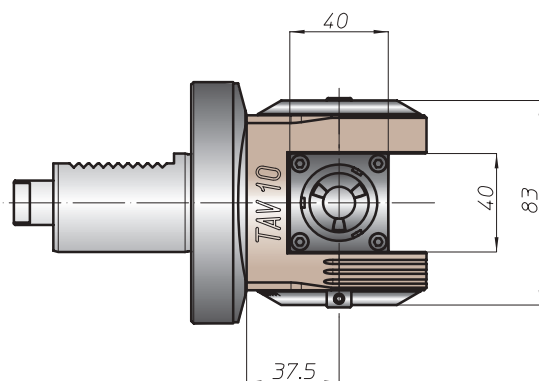
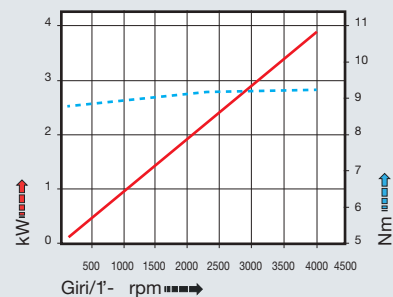

## soluzioni speciali - special solutions



FH  
BAH  
TA.CP  
TA

MO

HT

VH

TSI/TSX

T

MT-TC-TC3

Accessori  
Accessories

Appendice tecnica  
Technical supplement



# TAV13.PVDI

caratteristiche/features



peso/weight



rotazione/rotation



prestazioni/performance

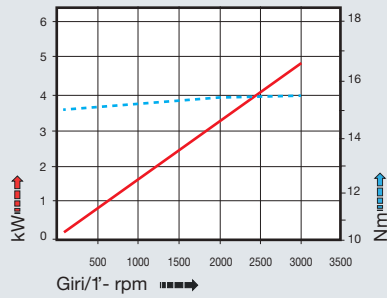

tipi mandrino disponibili / available spindle types

- 1** DIN6388-ER
  - 3** Weldon Whistle-Notch
- ER25** **Ø16**

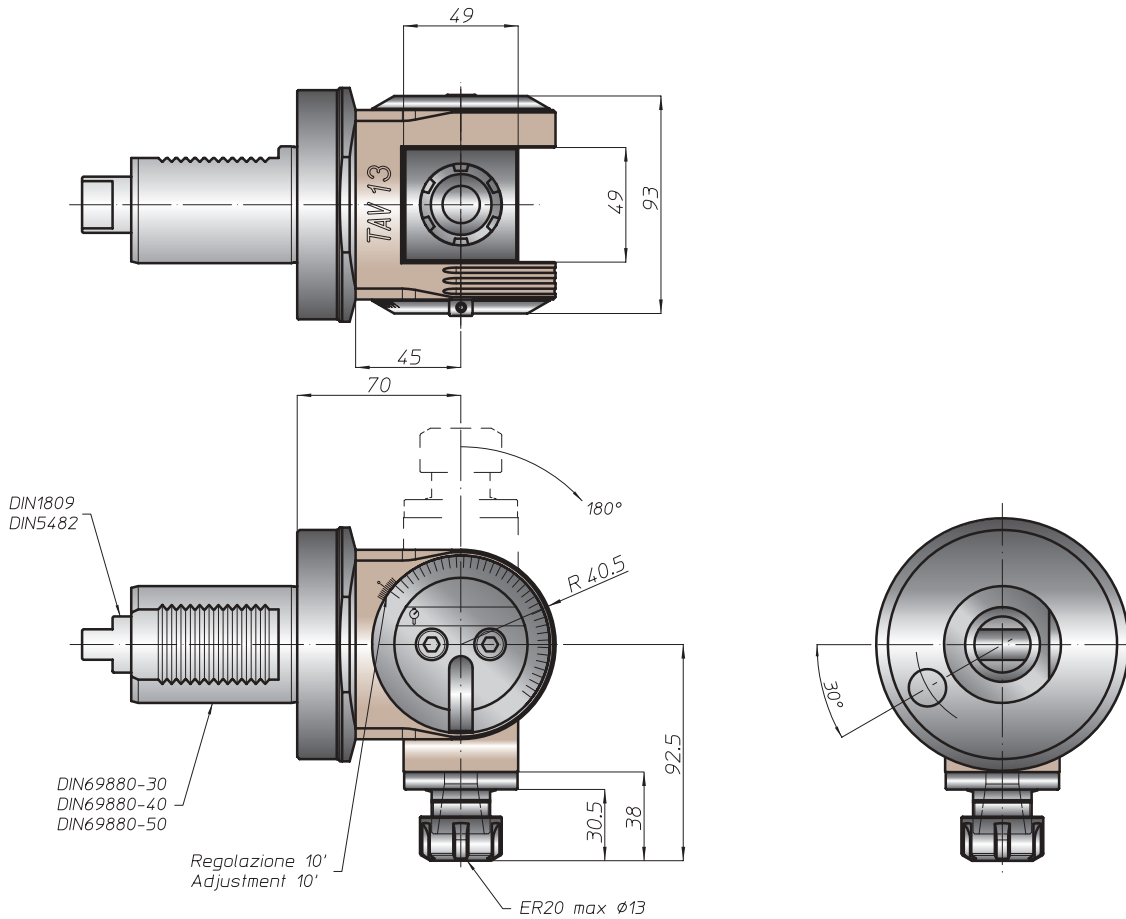

soluzioni speciali - special solutions



FH  
BAH  
TA.CP  
TA  
MO  
HT  
VH  
TSI/TSX  
T  
MT-TC-TC3  
Accessori  
Accessories



# Antirotante Torque arm

Teste ad angolo con interasse H=65  
Angle heads with centre distance H=65

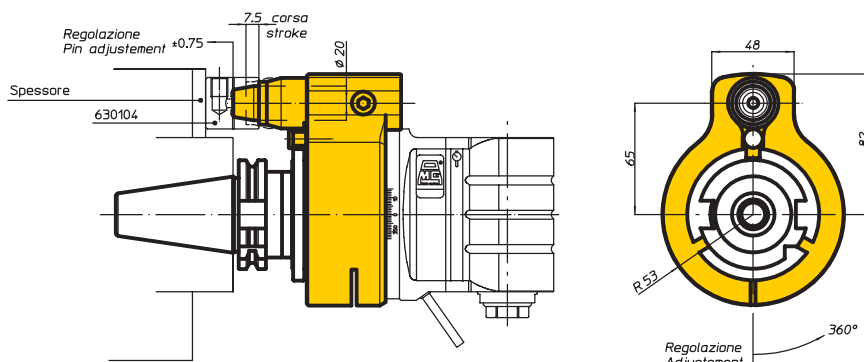

Il gruppo antirotante ricopre una funzione di fondamentale importanza nella qualità di lavorazione della testa ad angolo. Per questo motivo i tecnici della OMG hanno studiato e messo a punto un antirotante di nuova concezione i cui punti salienti sono:

- Il perno conico
- La registrazione assiale del perno
- Adduzione del liquido passante per il corpo testa

Il perno conico e la propria registrazione assiale di mm 1.5 permettono una maggiore rigidità del sistema antirotante rispetto ai tradizionali, dotati di perni di Ø18 mm perché si eliminano i giochi con conseguente miglioramento della rigidità sia angolare che assiale.

L'adduzione del liquido passante per il corpo testa, la cui uscita avviene tramite un ugello direzionabile, offre il vantaggio di non avere tubi "volanti" che possono muoversi durante le lavorazioni.

Teste ad angolo con interasse H=80  
Angle heads with centre distance H=80

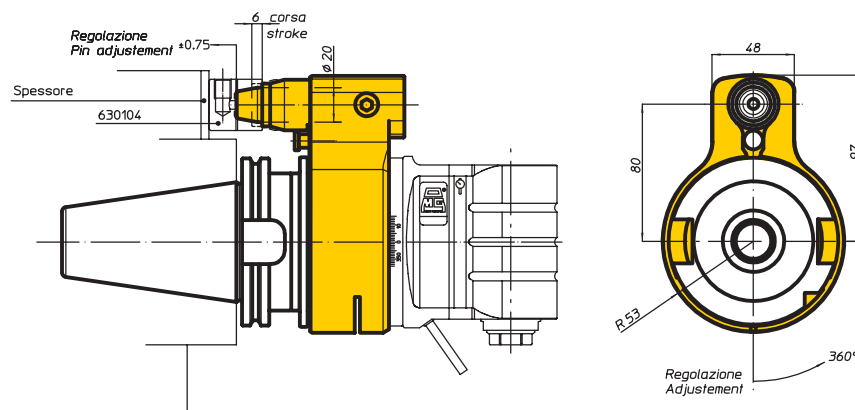

Teste ad angolo con interasse H=110  
Angle heads with centre distance H=110

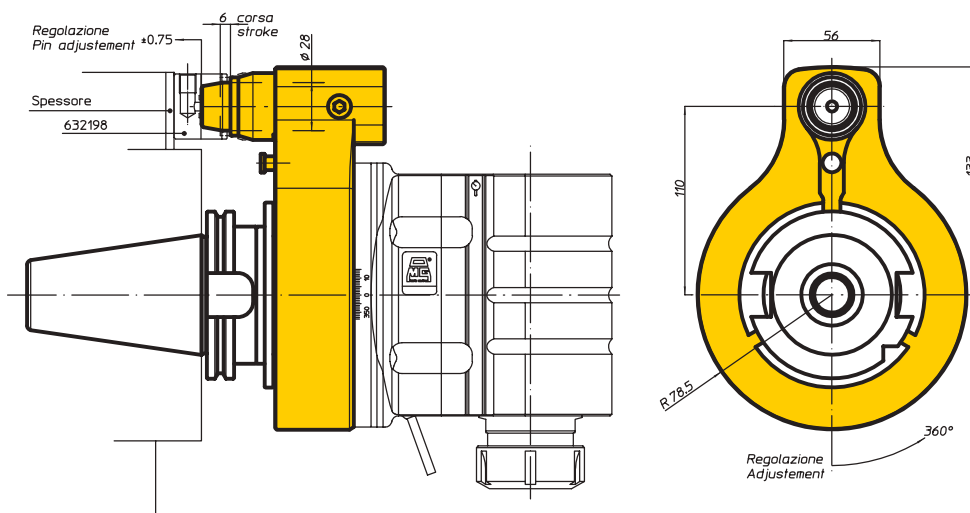

Quando possibile, nella Vostra applicazione, posizionate il perno conico dalla parte opposta al mandrino della testa ad angolo.



# Stop-block

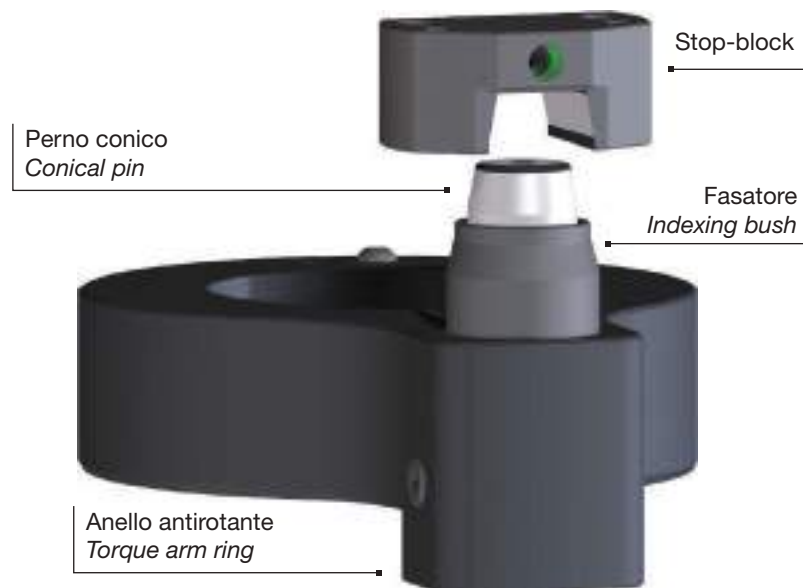

The torque arm system is crucial as far as angle-head machining quality is concerned. For this reason OMG technicians have designed and developed a new system with the following characteristics:

- conical pin
- axial pin adjustment
- coolant through the head body

The conical pin and its 1.5 mm axial adjustment ensure upgraded antirotation system strength compared to traditional systems, featuring  $\varnothing 18$  mm pin, because play is eliminated, thereby improving both angular and axial strength.

By the pin the coolant through the head, thanks to an adjustable nozzle, the added advantage is achieved of eliminating "free" pipes that could move during machining operations.

Double Stop-block (cod. 632199)

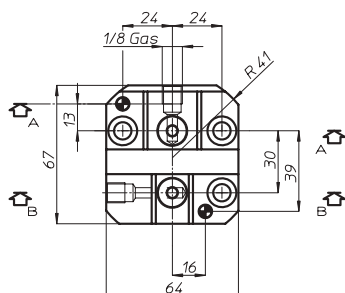
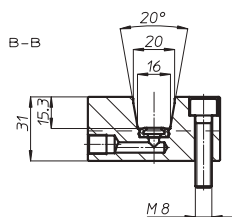
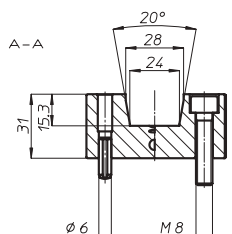

Stop-block (cod. 632198)

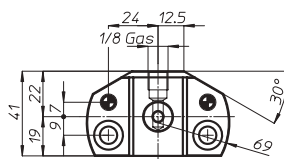
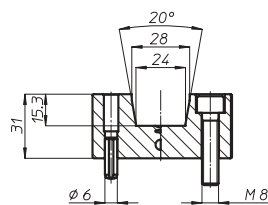

Stop-block (cod. 630104)

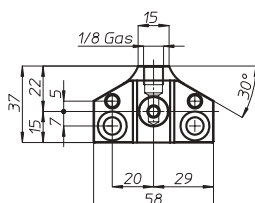
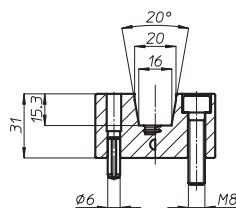

Position the conical pin on the opposite side of the angle head spindle when possible in your application.





# Antirotante/Torque arm

## Teste ad angolo con interasse H=65 Angle heads with centre distance H=65

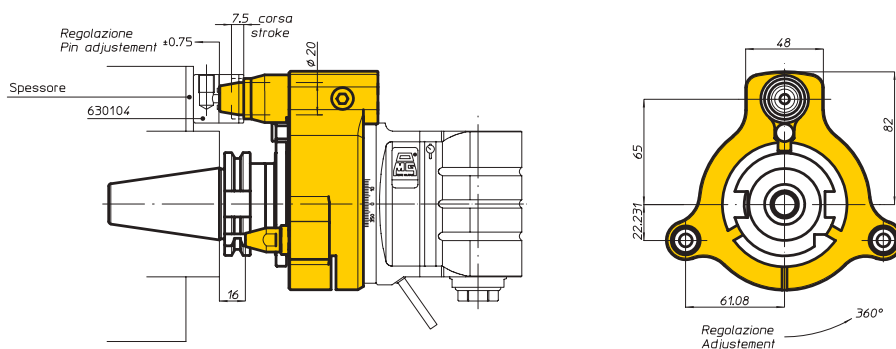

Il gruppo antirotante **TriBlock** ricopre una funzione di fondamentale importanza quando alla testa ad angolo è richiesto di:

- eseguire una lavorazione più pesante
- essere più lunga dello standard
- finitura superficiale eccellente

Il **TriBlock** è dotato di tre punti di appoggio di cui uno è lo standard come nei precedenti e due supplementari da registrare tramite un rasamento. Questi tre punti, allargando l'appoggio di base della testa ad angolo, consentono di ottenere una rigidità superiore allo standard. Quando poi si richiede alla testa di essere immagazzinata su di un supporto esterno al magazzino standard, ecco che il **TriBlock** utilizza i propri tre punti per posizionare la testa.

## Teste ad angolo con interasse H=80 Angle heads with centre distance H=80

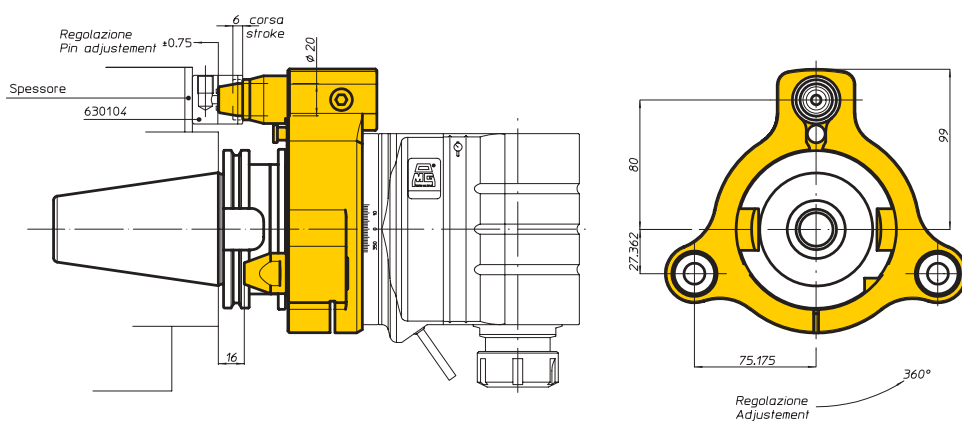

## Teste ad angolo con interasse H=110 Angle heads with centre distance H=110

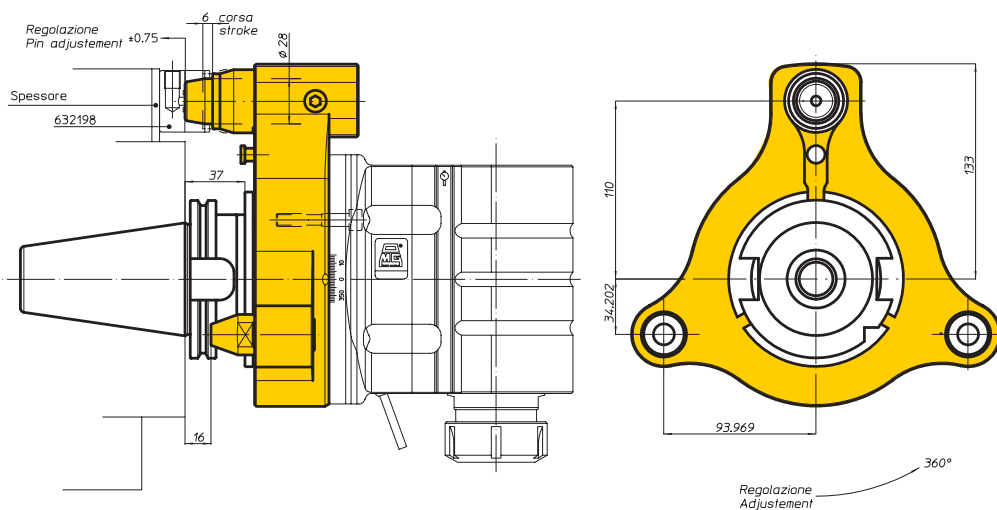



# Antirotante/Torque arm

Sul mandrino macchina  
On spindle machine

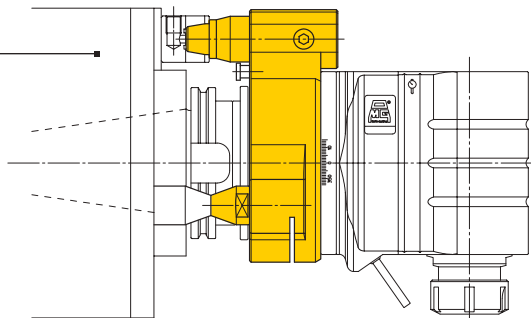

## TFS 19907

Testa ad angolo per fresatura  
componente motore a reazione.  
Peso Kg 45,5  
Milling angle head for jet engine.  
Weight Kg 45,5

## TFS 39195

Testa bimandrino di fresatura n° 2 frese  
Ø 100 peso Kg 33  
Twin milling head, nr. 2 milling cutter  
Ø 100 weight Kg 33

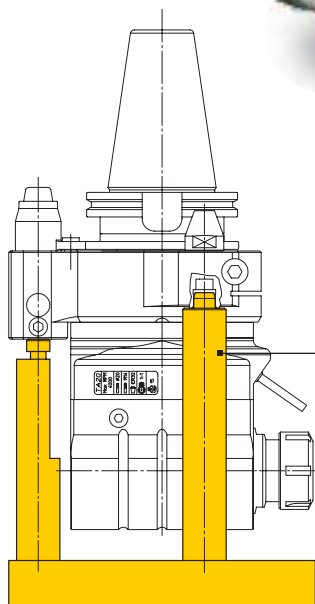

Sul supporto da tavola  
On rack table



The **TriBlock** system is of crucial importance when it comes to:

- doing difficult jobs
- having a head that is longer than standard
- achieving an excellent surface finish

The **TriBlock** system features three supporting points, one of which is standard, as in the previous version, plus two additional ones that need adjusting by means of a spacer. These three points, by extending the angle-head supporting base, provide above-average standards of strength.

When the head has to be stored on a rack table outside the standard magazine, the **TriBlock** system uses the three points to storage the angle heads.

FH

BAH

TA.CP

TA

MO

HT

VH

TSI/TSX

T

MT-TC-TC3

Accessori  
Accessories

Appendice tecnica  
Technical supplement

# Antirotante/Torque arm



## TAS13609

Fresatura su corpo in fusione di ghisa. Peso kg 36.  
*Milling on cast iron pump's body. Weight 36 kg.*



Il sistema antirotante **QuadBlock** è un sistema all'avanguardia per equipaggiare Teste ad Angolo dove si richiede alta asportazione e alta rigidità dell'insieme "testa ad angolo-macchina". Utilizzabile nel montaggio manuale, esso consiste in un anello antirotante completo di quattro perni di contrasto suddivisi equamente sui 360°. Tale disposizione consente di poter ruotare la Testa ad Angolo in automatico con un semplice movimento della macchina, se questa ne ha le capacità. Il vantaggio di poter lavorare quattro facce del pezzo senza sostituire la Testa ad Angolo si concretizza con la riduzione dei costi previsti per gli utensili.

L'evoluzione del sistema **QuadBlock** per le macchine con cambio automatico, consente di utilizzare la Testa ad Angolo come un prolungamento del mandrino macchina ruotato dei gradi richiesti dal cliente. È possibile inoltre sostituire il portautensile in automatico ed ampliare infinitamente la versatilità della macchina utensile avendo a disposizione quei servizi normalmente presenti sul mandrino macchina:

- Aria pulizia del portautensile
- Liquido refrigerante centro utensile alta pressione
- Liquido refrigerante esterno utensile
- Liquido bloccaggio-sbloccaggio utensile
- Controllo presenza utensile

Tutto ciò per consentire l'utilizzo di portautensili tipo Capto, HSK, DIN69871. Mettiamo a disposizione il nostro ufficio tecnico e la nostra esperienza per personalizzare al meglio il Vostro sistema.



## TAS13209

Lavorazione di finitura interna col motore idraulico. Peso kg 36.  
*Internal finishing work for hydraulic motor's body. Weight 21 kg.*

## TAS16209

Linee di servizio per il mandrino HSK63F con cambio automatico dell'utensile, sensore presenza utensile in radiofrequenza. Peso kg 28.  
*Utility line for HSK63F spindle with automatic tool change, radio-frequency switch to verify tool presence. Weight 28 kg.*



# Antirotante/Torque arm

## TAS24408

Lavorazione di fresatura interna  
corpo pinza freno in ghisa.  
Peso Kg 28.  
*Triblock with automatic locking.  
Cast iron brake housing internal  
milling work. Weight 28 kg.*

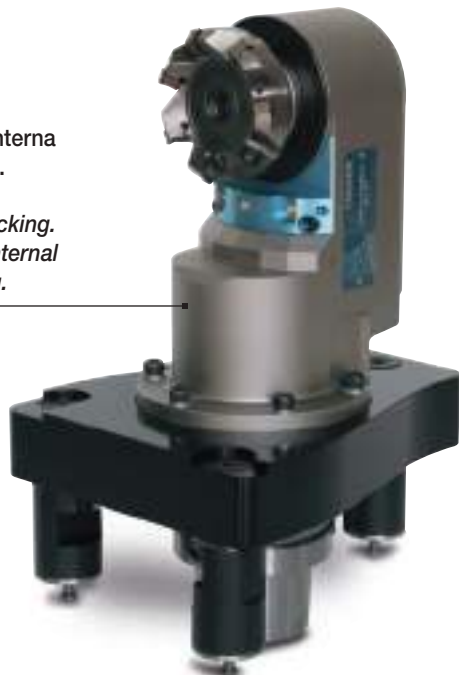

## TA12907

Lavorazione di fresatura generica  
struttura elettrosaldada di acciaio.  
Peso Kg 48.  
*Special Quadblock with automatic  
locking. General milling work on  
electro-welded steel structure.  
Weight 48 kg.*



## TAS08606

Servizi per mandrino CAPTO C4 con  
cambio automatico dell'utensile.  
Peso kg 36.  
*Spindle with utility line for CAPTO C4  
with automatic tool change.  
Weight kg 36.*



The **QuadBlock** torque arm is a forefront system to equip Angle Heads which are requested with a high removal machining capacity and with extremely high rigidity in coupling with the machine tool. It can be used with a manual tool change and is made by a torque arm ring complete with four counterposed pins with same distance each other on the 360°. Such a layout allows an automatic rotation of the Angle Head with a simple movement of the machine if featured to do it. The possibility of machining four faces of the piece without replacing the Angle Head is giving the advantage of reducing costs of tools equipment.

The evolution of the **QuadBlock** system on automatic tool change machines allows to use the Angle Head like an extension of the machine spindle with the degree rotations required by the customer. It is also possible to automatically change the tool holder and to infinitely widen the versatility of the machine tool getting those utilities normally available on the machine spindle:

- tool-holder cleaning air
- through-tool high pressure coolant
- side-tool coolant
- tool locking-unlocking liquid
- tool presence control

All these to allow using tool-holders like Capto, HSK, DIN69871. Our R&D department is at your disposal with his experience to customize your system at its best.

FH

BAH

TA.CP

TA

MO

HT

VH

TSI/TSX

T

MT-TC-TC3

Accessori  
AccessoriesAppendice tecnica  
Technical supplement

# Teste ad angolo speciali

## Special angle heads

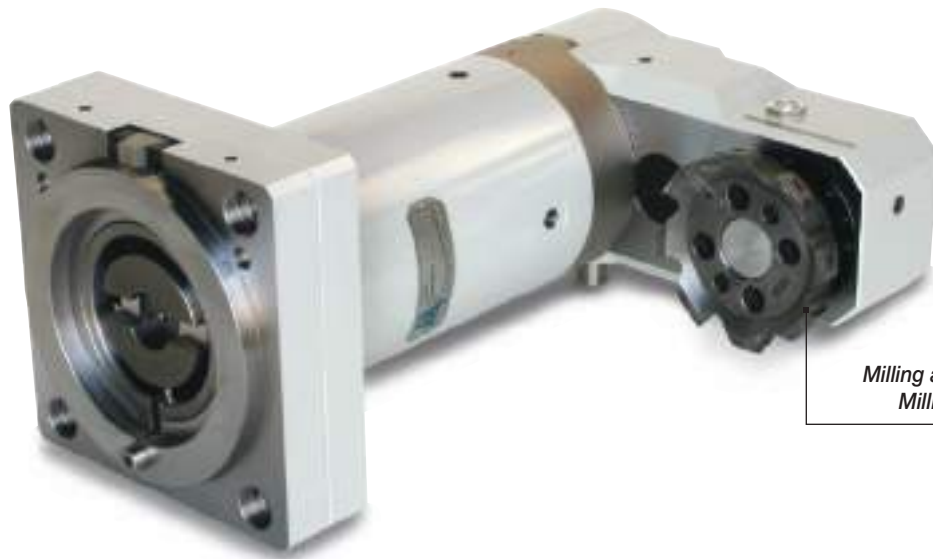

**TFS 41304**  
 Testa ad angolo di fresatura  
 con mandrino ribaltato.  
 Fresa Ø 200. Peso Kg 327,5.  
*Milling angle head with reverse spindle.  
 Milling tool Ø 200. Weight Kg 327,5.*



**TFS 05303**  
 Testa ad angolo di fresatura con  
 fresa diam. 7 peso Kg 8  
*Milling angle head with milling  
 cutter diam. 7 weight Kg 8*



**TAS 15505**  
 Testa ad angolo di foratura e fresa-  
 tura, attacco utensile CAPTO C4  
 automatico. Peso Kg 130.  
*Drilling and milling angle head, auto-  
 matic tools changer CAPTO C4.  
 Weight Kg 130.*



**TFS 23301**  
 Testa ad angolo di foratura  
 a tre mandrini peso kg 5,9  
*Drilling angle head with  
 three spindles weight kg 5,9*



**TFS 39998**  
 Testa ad angolo universale.  
 Presa utensili ISO50, peso kg 580  
*Angle head with tool  
 shank ISO50, weight kg 580*

FH

BAH

TA.CP

TA

MO

HT

VH

TSI/TSX

T

MT-TC-TC3

Accessori  
AccessoriesAppendice tecnica  
Technical supplement

# Teste ad angolo speciali

## Special angle heads



### TFS 34004

Testa ad angolo di foratura  
a 3 mandrini a 120°.  
Peso Kg 18.  
Drilling angle head, n 3  
spindles at 120°.  
Weight Kg 18.



### TFS 36699

Testa ad angolo bimandrino  
registrabile, peso kg 29  
Adjustable twin angle head,  
weight kg 29



### TA 09603

Testa ad angolo di alesatura con  
utensile Ø 160 peso Kg 77  
Boring angle head with tools  
Ø 160 weight Kg 77



### TFS 08993

Testa ad angolo speciale  
con doppia coppia  
di mandrini contrapposti  
peso kg 18  
Angle head with two  
opposite twin spindles  
weight kg 18



### TAF 37503

Doppia testa ad angolo di foratura.  
Twin drilling angle head.

### TFS 06003

Testa ad angolo di fresatura con  
fresa Ø 110 peso Kg 210  
Milling angle head with milling  
cutter Ø 110 weight Kg 210



FH

BAH

TA.CP

TA

MO

HT

VH

TSI/TSX

T

MT-TC-TC3

Accessori  
AccessoriesAppendice tecnica  
Technical supplement

# Teste ad angolo speciali

## Special angle heads



**TAS 33206**  
 Testa bimanodrino di fresatura  
 per frese Ø 160 peso kg 63  
*Twin milling head with  
 milling cutter Ø 160 weight kg 63*



**TFS 21701**  
 Testa di fresatura a due mandrini  
 paralleli, peso kg 14  
*Milling angle head with two parallel  
 spindles, weight kg 14*

**TFS 34495**  
 Testa bimanodrino di fresatura n. 2 frese Ø 130  
 peso kg 290  
*Twin milling head, nr. 2 milling cutter Ø 130  
 weight kg 290*

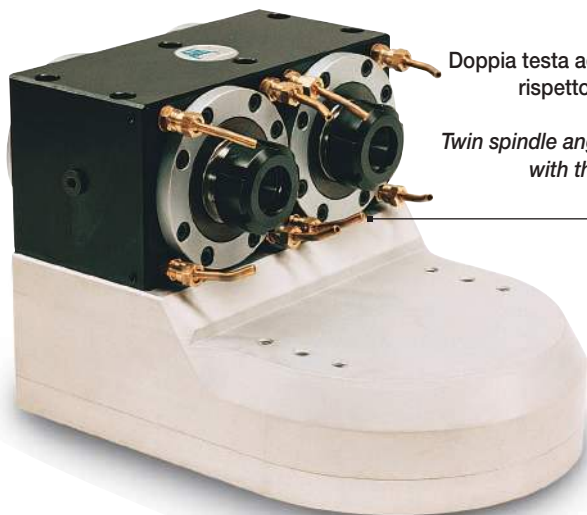

**TFS 16696**  
 Doppia testa ad angolo disassata  
 rispetto all'asse macchina  
 peso kg 24  
*Twin spindle angle head not in line  
 with the machine spindle  
 weight kg 24*

**TFS 36994**  
 Testa bimanodrino di fresatura  
 n. 2 frese Ø 60, peso kg 15,5  
*Twin milling head, nr. 2 milling  
 cutter Ø 60, weight kg 15,5*



FH

BAH

TA.CP

TA

MO

HT

VH

TSI/TSX

T

MT-TC-TC3

Accessori  
AccessoriesAppendice tecnica  
Technical supplement

# Teste ad angolo speciali

## Special angle heads



**TFS 12101**  
 Testa di fresatura con cono ISO30  
 peso kg 16  
*Milling angle head with ISO30  
 weight kg 16*



**TFS 13094**  
 Testa ad angolo disassata  
 rispetto all'asse macchina  
 peso kg 17  
*Angle head not in line  
 with the machine spindle  
 weight kg 17*

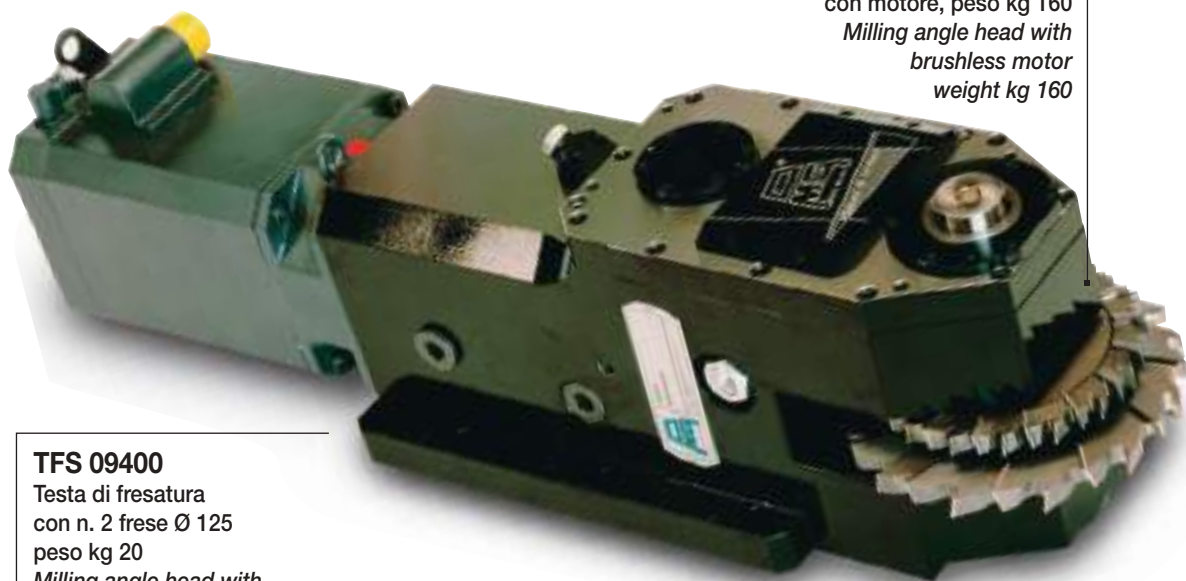

**TFS 50900**  
 Testa di fresatura  
 con motore, peso kg 160  
*Milling angle head with  
 brushless motor  
 weight kg 160*



**TFS 09400**  
 Testa di fresatura  
 con n. 2 frese Ø 125  
 peso kg 20  
*Milling angle head with  
 nr. 2 milling cutter Ø 125  
 weight kg 20*



**TFS 24196**  
 Testa ad angolo bimandrino per  
 fresatura su scatola del cambio  
 peso kg 70  
*Twin milling spindle angle head  
 on gear box weight kg 70*

FH

BAH

TA.CP

TA

MO

HT

VH

TSI/TSX

T

MT-TC-TC3

Accessori  
AccessoriesAppendice tecnica  
Technical supplement

# Teste ad angolo speciali

## Special angle heads

### TAS 41504

Testa ad angolo mandrino di fresatura. Peso Kg 338.  
*Twin milling angle head. Weight Kg 338.*



### TFS 35698

Testa ad angolo di fresatura con fresa Ø 100 peso Kg34  
*Milling angle head, with milling cutter Ø 100 weight Kg 34*



### TFS 12005

Testa ad angolo disassata per fresature Ø 150.  
Peso Kg 48.  
*Shift spindle angle head, milling tools Ø 150. Weight Kg 48.*



### TFS 28603

Testa di fresatura con n. 4 frese a disco Ø 125. Peso Kg 218.  
*Milling head, nr. 4 milling disc cutter Ø 125. Weight Kg 218.*



FH

BAH

TA.CP

TA

MO

HT

VH

TSI/TSX

T

MT-TC-TC3

Accessori  
AccessoriesAppendice tecnica  
Technical supplement



# Teste ad angolo speciali

## Special angle heads



**TFS 33303**  
 Testa ad angolo disassata  
 per foratura. Peso Kg 9,4.  
*Angle head with shift  
 drilling spindle.  
 Weight Kg 9,4.*

**TFS 12095**  
 Testa ad angolo di  
 foratura peso kg 5  
*Drilling angle head  
 weight Kg 5*



**TAS 30505**  
 Testa ad angolo di foratura  
 HSK100 entrata e uscita.  
 Peso Kg 50.  
*Drilling angle head, HSK 100  
 input-output. Weight Kg 50*

**TFS 33503**  
 Testa ad angolo di lucida-  
 tura con doppia rotazione,  
 sia corpo che utensile.  
 Peso kg 6,5.  
*Polish angle head with  
 duble rotation: body and  
 tools. Weight Kg 6,5.*



**TFS 13198**  
 Testa ad angolo  
 disassata per foratura  
 peso kg 5  
*Angle head with  
 shift spindle  
 weight kg 5*



FH

BAH

TA.CP

TA

MO

HT

VH

TSI/TSX

T

MT-TC-TC3

Accessori  
 Accessoires

Appendice tecnica  
 Technical supplement



# Teste ad angolo speciali

## Special angle heads



**TFS 39997**  
 Testa ad angolo speciale  
 bimandrino per foratura e  
 maschiatura peso kg 16  
*Twin angle head for  
 drilling and tapping  
 weight kg 16*

**TAS 13806**  
 Testa bimandrino Capto C5  
 manuale, peso kg 33  
*Twin angle head with Capto C5  
 manual clamping tool  
 weight kg 33*



**TAS 39806**  
 Testa di foratura a due mandrini  
 con refrigerante attraverso il  
 centro utensile a 50 Bar  
 peso kg 21  
*Twin drilling angle head with  
 coolant through the centre tool  
 at 50 Bar, weight kg 21*



**TAS 08606**  
 Testa fresatura conica su acciaio  
 peso kg 23  
*Milling angle head with conical tool  
 weight kg 23*

**TFS 40601**  
 Testa ad angolo bimandrino,  
 angolo tra i due mandrini 176°,  
 peso Kg 13  
*Twin angle head, angle 176°  
 between spindles, weight Kg 13*



FH

BAH

TA.CP

TA

MO

HT

VH

TSI/TSX

T

MT-TC-TC3

Accessori  
AccessoriesAppendice tecnica  
Technical supplement

# Teste ad angolo speciali

## Special angle heads



**TFS 20298**  
 Testa bimandrino di fresatura  
 n°2 frese Ø 120 peso kg 25  
*Twin milling angle head, nr.2  
 milling cutter Ø 120  
 weight kg 25*



**TA 05500**  
 Testa ad angolo di fresatura  
 con fresa Ø125 peso kg 17  
*Milling angle head with milling  
 cutter Ø 125, weight kg 17*

**TAS 20706**  
 Testa per fresatura interna  
 pinza freno peso Kg 23  
*Angle milling head for brake  
 housing weight Kg 23*



**TAS 39706**  
 Testa di fresatura per  
 supporto motore frese  
 Ø160/180 peso kg 31  
*Milling head for engine's  
 bracket milling cutter  
 Ø160/180 weight kg 31*



**TA 34397**  
 Testa ad angolo  
 di fresatura  
 con cono ISO20  
 peso kg 0,9  
*Milling angle head  
 with shank ISO20  
 weight kg 0,9*



**TFS 39999**  
 Testa ad angolo  
 speciale fresatura  
 su plastica peso kg 4  
*Milling angle head  
 for plastic weight kg 4*



**TA 17292**  
 Testa ad angolo di fresatura  
 n. 2 frese per legno  
 peso kg 3  
*Twin angle head with nr. 2  
 milling cutter for wood  
 weight kg 3*



FH

BAH

TA.CP

TA

MO

HT

VH

TSI/TSX

T

MT-TC-TC3

Accessori  
 Accessoires

Appendice tecnica  
 Technical supplement



# Teste ad angolo speciali

## Special angle heads



### TAS 37806

Testa ad Angolo di fresatura componente aeronautico, materiale Inconel. Peso Kg 40  
*Milling Angle Head for aeronautic piece, Inconel alloy material. Weight Kg 40*



### TFS 23910

Testa ad Angolo bimandri-  
no, fresatura di componente  
in ghisa. Peso Kg 50  
*Twin Angle Head, milling  
cast iron pieces.  
Weight Kg 50*



### TFS 31110

Testa ad Angolo di foratura  
con mandrino HSK50 ribal-  
tato. Peso Kg 31  
*Drilling Angle Head with  
HSK50 reverse spindle.  
Weight Kg 31*

### TAS 10708

Testa ad Angolo lunghezza  
mm 1.000, fresatura di cave  
su acciaio. Peso Kg 216  
*Angle Head overall lenght  
mm 1.000, milling key-way  
on steel. Weight Kg 216*



### TAS 13910

Testa ad Angolo di foratura  
con mandrino ER25.  
Peso Kg 31  
*Drilling Angle Head with  
ER25 spindle.  
Weight Kg 31*



FH

BAH

TA.CP

TA

MO

HT

VH

TSI/TSX

T

MT-TC-TC3

Accessori  
AccessoriesAppendice tecnica  
Technical supplement

# Teste ad angolo speciali

## Special angle heads



### TFS 05609

Testa ad Angolo di fresatura per tornio verticale.  
Peso Kg 286  
Milling Angle Head for vertical lathe. Weight Kg 286

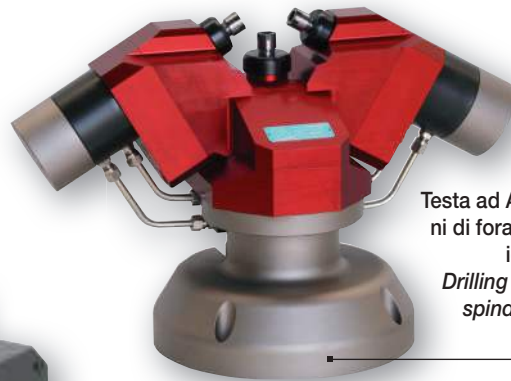

### TAS 08411

Testa ad Angolo con tre mandrini di foratura con avanzamento idraulico. Peso Kg 17,5  
Drilling Angle Head with three spindles, hydraulic spindles feed. Weight Kg 17,5

### TFS 26908

Testa ad Angolo bimandrino di foratura per macchina transfer. Peso Kg 9,5  
Twin drilling Angle Head for transfer machine. Weight Kg 9,5



**TAS 19610**  
Testa ad Angolo di fresatura per macchina transfer.  
Peso Kg 35  
Milling Angle Head for transfer machine. Weight Kg 35



### TAS 28010

Testa ad Angolo con tre assi a regolazione manuale.  
Peso Kg 590  
Angle Head with three manual movement axis. Weight Kg 590



FH

BAH

TA.CP

TA

MO

HT

VH

TSI/TSX

T

MT-TC-TC3

Accessori  
AccessoriesAppendice tecnica  
Technical supplement

# Teste ad angolo speciali

## Special angle heads



**TAS 19010**  
 Testa ad Angolo di foratura per macchina transfer. Max RPM 20.000.  
 Peso Kg 5  
*Drilling Angle Head for transfer machine. Max RPM 20.000. Weight Kg 5*



**TAS 09407**  
 Testa ad Angolo per fresatura canna di fucile.  
 Peso Kg 6,5  
*Milling Angle Head for rifle barrel. Weight Kg 6,5*

**TAS 16308**  
 Testa ad Angolo di foratura con mandrino HSK32 a cambio automatico utensile. Peso Kg 13,5  
*Drilling Angle Head with spindle HSK32 with automatic tool changer. Weight Kg 13,5*

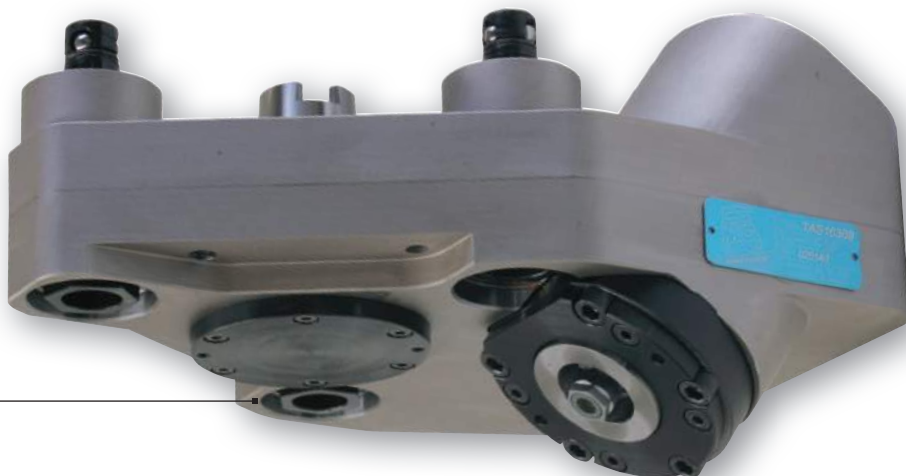

**TAS 26810**  
 Testa ad Angolo TAO20, utilizzata in fresatura su torretta a revolver HT250. Peso Kg 14  
*Milling Angle Head TAO20, assembled on HT250 turret head. Weight Kg 14*



**TFS 06906**  
 Testa ad Angolo di foratura scatola sterzo. Peso Kg 10  
*Drilling Angle Head for steering body. Weight Kg 10*

FH

BAH

TA.CP

TA

MO

HT

VH

TSI/TSX

T

MT-TC-TC3

Accessori  
AccessoriesAppendice tecnica  
Technical supplement

# Teste ad angolo speciali

## Special angle heads

### TAS 24508

Testa ad Angolo di fresatura  
pinza freno. Peso Kg 29  
*Milling Angle Head for brake  
truck body. Weight Kg 29*



### TAS 07309

Testa ad Angolo di fresatura,  
basamento motore 12 cilindri.  
Peso Kg 60  
*Milling Angle Head, 12 cylinder  
engine block. Weight Kg 60*

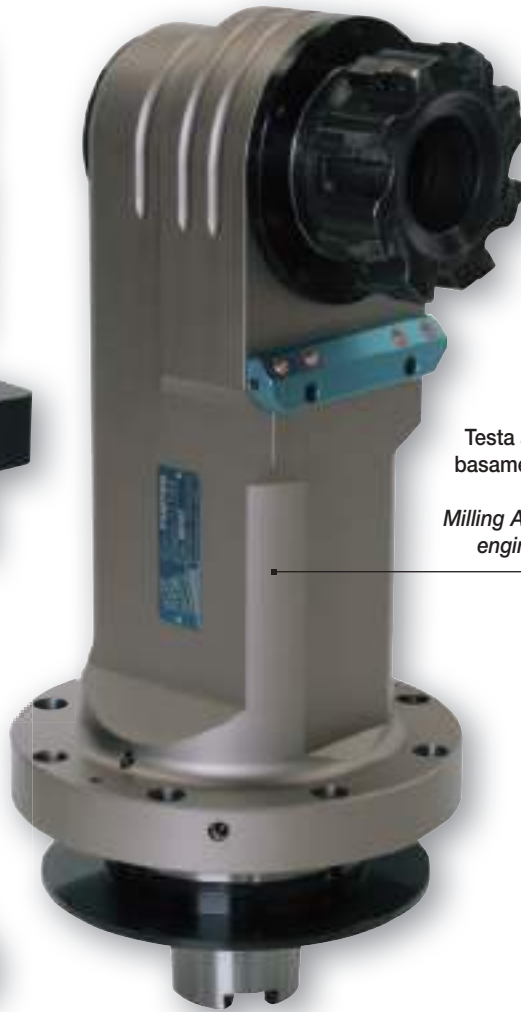

### TAS 24010

Testa ad Angolo di foratura componente  
aeronautico in alluminio.  
Peso Kg 13,5  
*Drilling Angle Head for aluminium  
aeronautic component. Weight Kg 13,5*



### TAS 07509

Testa ad Angolo bimanadrino di alesatura,  
motore 12 cilindri. Peso Kg 63  
*Twin spindle boring Angle Head, 12  
cylinder engine block. Weight Kg 63*



### TAS 28606

Testa ad Angolo di foratura componen-  
te aeronautico con mandrino HSK50,  
materiale Inconel. Peso Kg 27  
*Drilling Angle Head with HSK50 spin-  
dle for aeronautic piece, Inconel alloy  
material. Weight Kg 27*

